

W-Series, Metric Cassettes and Reducers

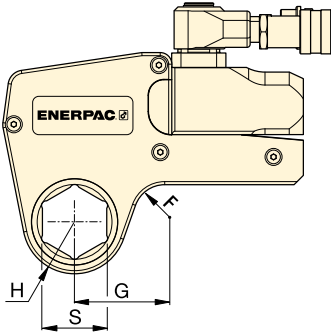

Hexagon Range:
50 - 155 mm

Maximum Operating Pressure:
690 bar

W
Series
X-Edition



▼ SELECTION CHART

Drive Unit Model Number	Hexagon Size ¹⁾	Nose Radius	Dim.	Model Nr. Cassette	Weight (kg)	Hexagon Reducer		Hexagon Reducer	
						Hexagon Reducer (mm)	Model Number Reducer	Hexagon Reducer (mm)	Model Number Reducer
W15000X (20.785 Nm)	65	59,0	89	W15209X	13,6	-	-	-	-
	70	59,0	89	W15212X	13,6	-	-	-	-
	75	62,0	91	W15215X	13,7	-	-	-	-
	80	64,5	93	W15302X	13,8	80 - 65	W15302R209	-	-
	85	69,5	97	W15085MX	14,1	85 - 70	W15085R070M	-	-
	90	75,0	102	W15090MX	14,5	90 - 75	W15090R075M	-	-
	95	75,0	102	W15312X	14,6	95 - 80	W15312R302	95 - 75	W15312R215
	100	80,5	103	W15315X	14,8	-	-	-	-
	105	80,5	103	W15402X	14,8	105 - 90	W15402R090M	-	-
	110	87,5	115	W15405X	15,1	110 - 95	W15110R095M	-	-
	115	87,5	115	W15115MX	15,1	115 - 100	W15115R100M	-	-
W22000X (30.506 Nm)	75	67,0	102	W22215X	22,0	-	-	-	-
	80	67,0	102	W22302X	21,6	80-60	W22302R206	80 - 55	W22302R203
	85	73,0	107	W22085MX	22,5	85-65	W22085MR209	85 - 60	W22085MR206
	90	77,9	113	W22090MX	23,4	90-70	W22090MR212	90 - 60	W22090MR206
	95	77,9	113	W22312X	22,9	95-75	W22312R215	-	-
	100	85,1	120	W22315X	24,3	-	-	-	-
	105	85,1	120	W22402X	23,4	-	-	-	-
	110	89,9	125	W22405X	24,6	-	-	-	-
	115	89,9	125	W22115MX	24,0	-	-	-	-
	120	95,0	130	W22412X	24,7	-	-	-	-
	123	95,0	130	W22123MX	24,4	-	-	-	-
W35000X (47.454 Nm)	130	100,0	135	W22502X	25,0	-	-	-	-
	135	100,0	135	W22506X	23,9	135 - 105	W22506R402	-	-
	80	76,0	129	W35302X	32,8	80 - 50	W35302R200	-	-
	85	76,0	129	W35085MX	32,3	-	-	-	-
	90	81,5	135	W35090MX	33,5	90 - 60	W35090R206	-	-
	95	81,5	135	W35312X	32,9	-	-	-	-
	100	87,0	139	W35315X	34,1	-	-	-	-
	105	87,0	139	W35402X	33,5	-	-	-	-
	110	93,0	146	W35405X	34,9	110 - 85	W35405R085M	-	-
	115	93,0	146	W35115MX	34,2	-	-	-	-
	120	100,0	153	W35412X	35,6	120 - 95	W35412R312	-	-
	123	100,0	153	W35123MX	35,0	-	-	-	-
	130	103,0	160	W35502X	35,8	130 - 105	W35502R402	-	-
	135	103,0	160	W35506X	34,6	135 - 110	W35506R405	-	-
	140	110,0	163	W35508X	36,2	140 - 115	W35508R115M	-	-
	145	110,0	163	W35512X	34,9	145 - 120	W35512R412	-	-
	150	114,0	164	W35514X	36,7	-	-	-	-
151	114,0	164	W35151MX	36,5	-	-	-	-	
155	114,0	164	W35602X	35,3	155 - 130	W35602R502	-	-	

¹⁾ See page 407 for table of hexagon sizes of bolts, nuts and related thread diameters.