

**PRODUCT SPECIFICATIONS**

Floor Mount Double Foot Valve. Overall dimensions are 5-5/8" x 4-7/8" x 2". Made of Chrome-plated Brass.

<b>Material:</b>	Chrome-plated Brass
<b>Dimensions:</b>	5-5/8" x 4-7/8" x 2"
<b>Shipping Weight:</b>	3 lbs.

- Double-foot mixing valve.
- 1/2" I.P.S. female inlets and outlet.
- Rough, chrome-plated floor mount valves.
- Certified to NSF/ANSI/CAN 61 and 372 to meet all federal and state regulations for low or no-lead products.
- Hot and cold color-indexed.



**A Century of Tradition and Quality.**

For more than 100 years, Elkay has been making innovative products and providing exceptional customer care. We take pride in offering plumbing products that make life easier, inspire change and leave the world a better place.

[Clean and Care Manual \(PDF\)](#)

[Warranty \(PDF\)](#)

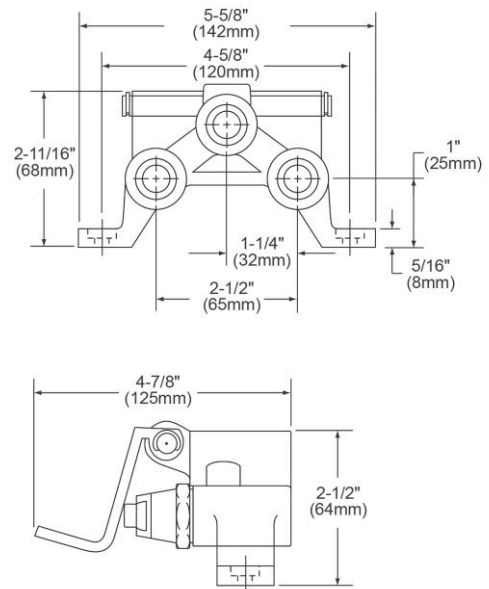

PART: \_\_\_\_\_ QTY: \_\_\_\_\_

PROJECT: \_\_\_\_\_

CONTACT: \_\_\_\_\_

DATE: \_\_\_\_\_

NOTES: \_\_\_\_\_

APPROVAL: \_\_\_\_\_

*In keeping with our policy of continuing product improvement, Elkay reserves the right to change product specifications without notice. Please visit [elkay.com](http://elkay.com) for the most current version of Elkay product specification sheets. This specification describes an Elkay product with design, quality, and functional benefits to the user. When making a comparison of other producers' offerings, be certain these features are not overlooked.*