

Dold Standstill Monitor Relays



UG6946-02PS-40

Dold speed monitoring safety relay modules provide safe standstill detection on 3-phase and single-phase motors by monitoring remanence voltage.

- Can monitor motor voltages up to 690 VAC or VDC
- No external sensors necessary
- Independent of direction
- Broken wire detection
- Monitors rotation and linear movement
- 2-channel operation for standstill monitoring
- Up to 3 NO and 1 NC positive-guided safety contacts
- LED status indicator
- Adjustable voltage setting
- Adjustable standstill time delay
- Semiconductor outputs for monitoring

Safety Data – Values per EN ISO 13849-1	
Category	4 according to EN ISO 13849-1
Performance level	PL _e according to EN ISO 13849-1
MTTF_d	>93 years for LH5946 >222 years for UG6946
DC_{avg}	99%
Safety Data – Values per IEC/EN 62061 /IEC/EN 61508	
SIL CL	3 per IEC/EN 62061
SIL	3 per IEC/EN 61508
HFT (Hardware Failure Tolerance)	1
DC_{avg}	99%
PFH_D	4.10 x 10 ⁻¹⁰ for LH5946 4.20 x 10 ⁻¹⁰ for UG6946

Safety Standstill Monitor Relays Selection Chart							
Part Number	Price	Marking Type	Voltage Monitor Range	Voltage	Outputs	Muting	Drawing
LH5946-48-24-04	\$526.00	Standstill-monitoring safety relay module	20mV to 400mV	24 VDC	3 NO / 1 NC	No	PDF
LH5946-48-115-04	\$526.00			115 VAC		No	PDF
UG6946-02PS-04	\$347.00			24 VDC	2 NO / 1 NC	No	PDF
UG6946-02PS-001-04	\$367.00			24 VDC		Yes	PDF
LH5946-48-24-40	\$526.00	Standstill-monitoring safety relay module	200mV to 4V	24 VDC	3 NO / 1 NC	No	PDF
LH5946-48-115-40	\$526.00			115 VAC		No	PDF
UG6946-02PS-40	\$347.00			24 VDC	2 NO / 1 NC	No	PDF
UG6946-02PS-001-40	\$367.00			24 VDC		Yes	PDF

Note: The -04 models are recommended for applications where motors are controlled directly from contactors. The -40 models are recommended for applications involving VFDs or soft starters where OFF-state leakage is present and higher voltage settings are required.

Dold Standstill Monitor Relays

Safety Standstill Monitor Relays Specification Table																				
General Specifications	LH5946	UG6946																		
Temperature	Storage: -40°C to 75°C (-40°F to 167°F) Operating: -25°C to 60°C (-13°F to 140°F)																			
Altitude	< 2,000 meters																			
Vibration Resistance	Amplitude: 0.35 mm Frequency: 10 to 55 Hz (IEC/EN 60068-2-6)	Amplitude: 0.075mm Frequency: 10 to 57 Hz (IEC/EN 60068-2-6)																		
Degree of Protection	Housing: IP40 Terminals: IP20																			
Housing	Thermoplastic with VO behavior; DIN rail mount																			
Weight	400g (14.11 oz.)	295g (10.41 oz.)																		
Agency Approvals and Standards	cULus file E107778, CE, TUV																			
Wire Connections	1x AWG 20-12 solid or stranded 2x AWG 20-14 solid or stranded	1x AWG 24-12 solid or stranded 2x AWG 24-18 solid or stranded																		
Wire Fixing	Plus-minus terminal screws M3.5 box terminals with wire protection. Torque 0.8 Nm [7 lb·in]	Captive slotted screw. Torque 0.8 N·m																		
Input Specifications																				
Nominal Voltage	24VDC, 115VAC, 230VAC	24VDC																		
Measuring/Motor Voltage	690 VAC/VDC (for UL applications, max 600 VAC/VDC)																			
Input Resistance	500KΩ																			
Response Value U_{an}	20 mV to 400 mV, adjustable or 0.2 to 4V adjustable																			
Response Value Dependent on Frequency	<table border="1"> <thead> <tr> <th>Input Frequency (Hz)</th> <th>50</th> <th>100</th> <th>200</th> <th>400</th> <th>600</th> <th>1k</th> <th>1.5k</th> <th>2k</th> </tr> </thead> <tbody> <tr> <td>Response Value U_{an}</td> <td>1.0</td> <td>1.1</td> <td>1.2</td> <td>1.5</td> <td>2.0</td> <td>2.8</td> <td>5</td> <td>8</td> </tr> </tbody> </table>		Input Frequency (Hz)	50	100	200	400	600	1k	1.5k	2k	Response Value U_{an}	1.0	1.1	1.2	1.5	2.0	2.8	5	8
Input Frequency (Hz)	50	100	200	400	600	1k	1.5k	2k												
Response Value U_{an}	1.0	1.1	1.2	1.5	2.0	2.8	5	8												
Voltage Range	AC: 0.8 to 1.1 U_N . At 10% residual ripple: 0.9 to 1.1 U_N DC: 0.9 to 1.2 U_N . At 10% residual ripple: 0.9 to 1.1 U_N	DC: 0.9 to 1.2 U_N . At 10% residual ripple: 0.9 to 1.1 U_N																		
Nominal Consumption	3W																			
Nominal Frequency	50 to 60 Hz. Frequency range: 45 to 65 Hz	N/A																		
Control Current	Control current typical at 24V over two relays: 75mA																			
Overvoltage Protection	Internal VDR (Voltage Dependent Resistor)																			
Output Specifications																				
Electrical Contact Life	To AC15 at 3A, 230V: 2x10 ⁵ switching cycles IEC/EN 60 947-5-1																			
Mechanical Life	50 x 10 ⁶ switching cycles	20 x 10 ⁶ switching cycles																		
Contact Type	3 NO positively driven and 1 NC relay contacts (NO contacts are safety contacts)	2 NO positively driven and 1 NC relay contacts (NO contacts are safety contacts)																		
Operate Delay on Standstill	Depends on setting; adjust by potentiometer																			
Release Delay for Detection of Running Motor	< 100ms																			
Nominal Output Voltage	250VAC	250VAC (for NO contacts) 24VDC (for NC contacts)																		
Thermal Current (I_{th})	5A per contact See continuous current limit curve in manual.	5A (for NO contacts) 2A (for NC contacts) See quadratic total current limit curves in manual.																		
Short Circuit Strength	Max fuse rating: 4 AGL (IEC/EN 60 9470-5-1), line circuit breaker C6A																			
Switching Capacity IEC/EN 60 947-5-1	AC 15: NO contacts: 3A/230V NC contacts: 1A/230VAC DC13: 4A/24V	AC 15: NO contacts: 3A/230V DC13: 4A/24V																		
Switching Frequency	Max. 1,200 switching cycles/hr																			
Semiconductor Monitoring	100 mA DC 24V; supply via A3+/A4	N/A																		

Dold UG6946 Standstill Monitor Relays

Applications

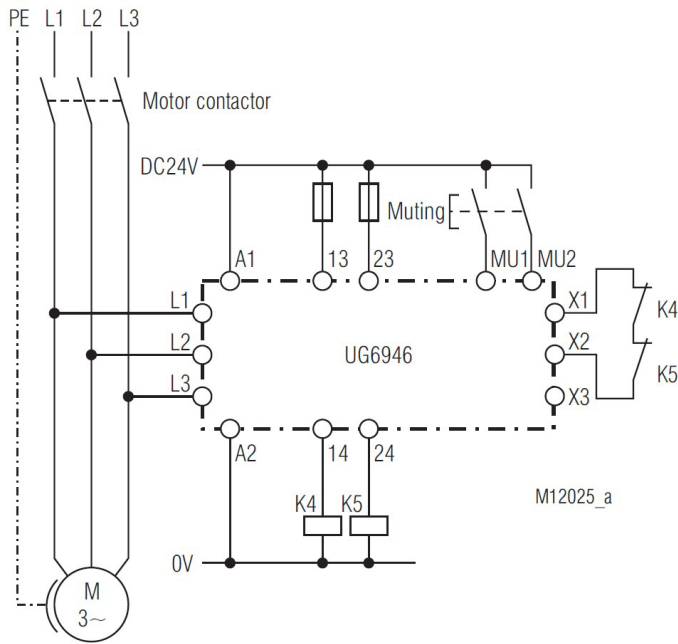

With 3-phase motor

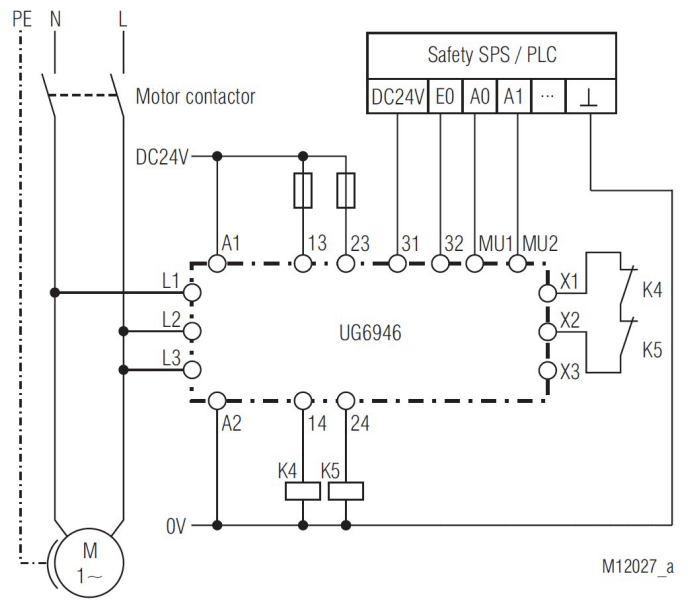

With single-phase motor

Function Diagram

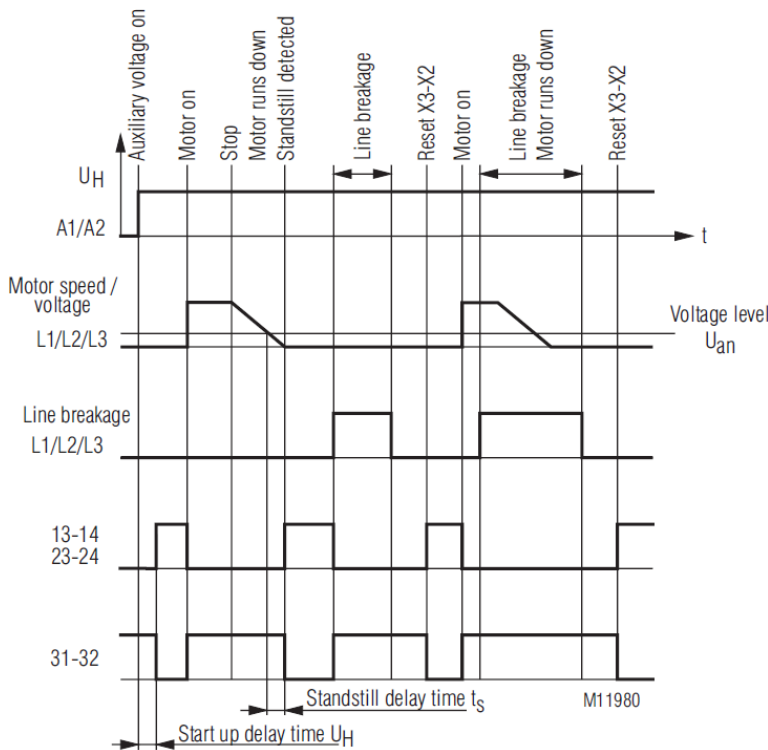

Connection Terminals	
Terminal Designation	Signal Description
L1-L2-L3	Connection to monitored motor
31-32	Forcibly guided indicator output
13-14, 23-24	Forcibly guided NO contacts for release circuit
X1-X2	Connection of feedback circuit (for external contactors)
X2-X3	Manual reset for external faults
A1-A2	Auxiliary supply (U_H)
MU1, MU2	Muting inputs

Setting	
Potentiometer U_{an}	Adjustment of voltage level for standstill detection
Potentiometer t_s	Adjustment of time delay before activation of safety contacts

Safety Products



Warning: Safety products sold by AutomationDirect are Safety components only. The purchaser/installer is solely responsible for the application of these components and ensuring all necessary steps have been taken to assure each application and use meets all performance and applicable safety requirements and/or local, national and/or international safety codes as required by the application. AutomationDirect cannot certify that our products, used solely or in conjunction with other AutomationDirect or other vendors' products, will assure safety for any application. Any person using or applying any products sold by AutomationDirect is responsible for learning the safety requirements for their individual application and applying them, and therefore assumes all risks, and accepts full and complete responsibility, for the selection and suitability of the product for their respective application.

AutomationDirect does not provide design or consulting services, and cannot advise whether any specific application or use of our products would ensure compliance with the safety requirements for any application.