

# Dold LG5928 Series – Dual Channel Safety Relay with Delay



Designed to protect people and machines in applications with E-stop buttons and safety gates. One or two channels can be monitored with time-delay function.

- Compact, flexible and safe
- Short response time
- LED indicators for power and state of operation
- Performance Level (PL) e and category 4 to EN ISO 13849-1: 2008
- SIL Claimed Level (SIL CL) 3 to IEC/EN 62061
- Safety Integrity Level (SIL) 3 to IEC/EN 61508 and IEC/EN 61511
- Output: 2 N.O. instantaneous contacts and 1 N.O. Release-Delayed contact
- 1- or 2-channel connection
- Line fault detection at the ON pushbuttons at connection on terminals S33-S34

- Manual restart with button on S33-S34 or automatic restart with bridge between S13-S34
- With or without cross fault monitoring in the E-stop loop
- Indication for released time circuit
- LED indication for supply, channel 1/2 and Release-Delayed contacts



Safety Relays					
Part Number	Price	Marking Type	Voltage	Outputs	Time Delay
<a href="#">LG5928-41-61-3</a>	\$279.00	Dual safety relay module	24VDC	2 N.O. instantaneous positive guided safety contact(s), 1 N.O. time delay positive guided safety contact(s)	0.3 to 3 second
<a href="#">LG5928-41-61-10</a>	\$279.00		24VDC	2 N.O. instantaneous positive guided safety contact(s), 1 N.O. time delay positive guided safety contact(s)	1 to 10 second
<a href="#">LG5928-41-61-60</a>	Retired	Please consider <a href="#">LG5928-41-61-10</a> as a comparable replacement.			

Safety Data – Values per EN ISO 13849-1		
	Non-Delayed Contacts	Delayed Contacts
Category	4	3
Performance level	PLe	PLd
MTTF <sub>d</sub>	351.8 years	495.4 years
DC <sub>avg</sub>	99%	97.3%

  

Safety Data – Values per IEC/EN 62061 /IEC/EN 61508		
SIL CL	3	2
SIL	3	2
HFT (Hardware Failure Tolerance)	1	1
DC <sub>avg</sub>	99%	97.3%
SFF	99.9%	99.1%
PFH <sub>D</sub>	1.37E <sup>-10</sup> h <sup>-1</sup>	2.76E <sup>-10</sup> h <sup>-1</sup>

### Function Diagram

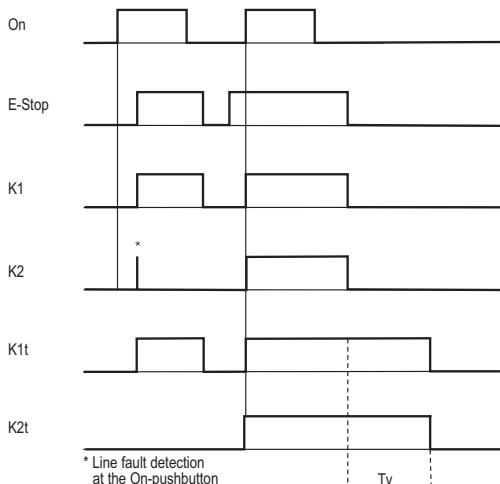

### Block Diagram

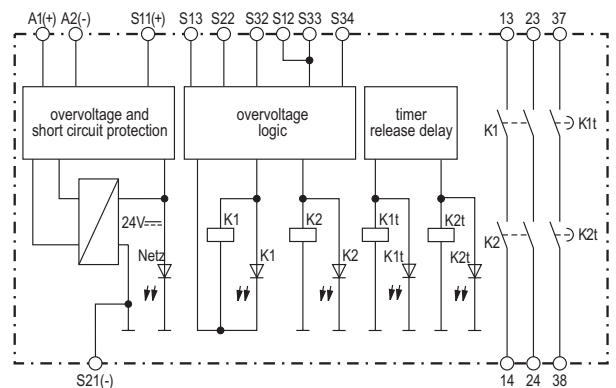

# Dold LG5928 Series – Dual Channel Safety Relay with Delay

Dual Channel Safety Relay with Delay Specification Table	
General Specifications	
Temperature	Storage: -25°C to 85°C (-13°F to 185°F) Operating: -15°C to 55°C (5°F to 131°F)
Altitude	< 2,000 meters
Vibration Resistance	Amplitude: 0.35mm, Frequency: 10 to 55 Hz (IEC/EN 60-068-2-6)
Degree of Protection	Per IEC/EN 60 529. Housing: IP40; Terminals IP20
Housing	UL 94V-0 Thermoplastic; Din mount 35 mm x 7.5 mm
Weight	210 g (7.41 oz.)
Agency Approvals and Standards	cULus file E107778, CE, RoHS
Terminal Designation per EN 50 005 Wire Connections	1x4 mm <sup>2</sup> solid or 2 x 2.5 mm <sup>2</sup> stranded ferruled (isolated) or 2 x 1.5 mm <sup>2</sup> stranded ferruled (isolated) DIN 46 228-1/-2/-3/-4 or 2 x 2.5 mm <sup>2</sup> stranded ferruled DIN 46 228-1/-2/-3
Wire Fixing	Box terminal with wire protection
Wire Connection	60degC/75degC Copper conductors only; AWG20-12 Sol/Str Torque 0.8NM
Input Specifications	
Nominal Voltage	24VDC
Voltage Range	At 10% residual ripple: DC: 0.9 to 1.1 UN At 48% residual ripple: DC: 0.8 to 1.1 UN
Maximum Consumption	DC approx. 3.5W
Minimum Off-time	1.0 second
Short Circuit Protection	Internal with PTC (Positive Temperature Coefficient resistor)
Overvoltage Protection	Internal VDR (Voltage Dependent Resistor)
Output Specifications	
Electrical Contact Life	To DC 13 at 2A, DC 24V: >1.5 x 10 <sup>5</sup> switching cycles To AC 15 at 2A, 230VAC: 10 <sup>5</sup> switching cycles IEC/EN 60 947-5-1
Mechanical Life	10 x 10 <sup>6</sup> switching cycles
Contact Type	2 N.O. contacts instantaneous and 1 contact release delay
Operate Delay	Operate delay typ at UN: manual start: 25 ms; automatic start: 100ms;
Release Delay	Release delay typ at UN: Disconnecting supply: 20 ms; Disconnecting S12, S22, S31 and S32: 10ms
Repeat Accuracy	±1% of setting value
Nominal Output Voltage	AC: 250V; DC: See continuous current limit curve in manual.
Thermal Current (Ith)	Max. 8A/6A, See quadratic total current curve in manual.
Switching of Low Loads	M100 mV; (contacts with 5μ Au) M 1 mA
Short Circuit Strength	Max. fuse rating: 10 A gL (IEC/EN 60 947-5-1); Line circuit breaker B 6 A
Switching Capacity	AC 15: N.O. contacts: 3A/230V; DC 13: N.O. contacts: 2A/24VDC
Switching Frequency	Max. 360 switching cycles/hr, with short release delay time
Indicator Contact	DC 13: N.C. contact: 2A/24VDC
Agency Approvals and Standards	cULus file E107778, CE, RoHS

To obtain the most current agency approval information, see the Agency Approval Checklist section on the specific part number's web page at [www.automationdirect.com](http://www.automationdirect.com)

## Connection Terminals

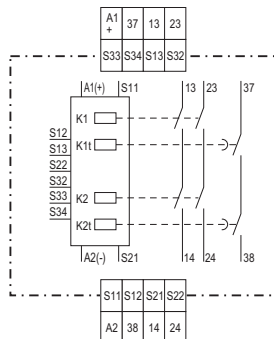

## Dimensions mm(in)

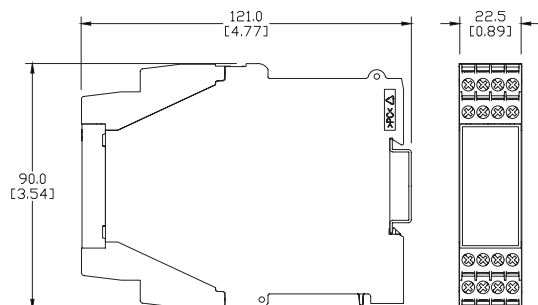

See our website: [www.AutomationDirect.com](http://www.AutomationDirect.com) for complete Engineering Drawings.

# Dold LG5928 Series – Dual Channel Safety Relay with Delay

## Application Examples

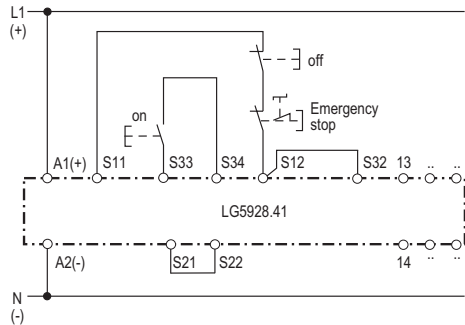

Single channel emergency stop circuit. This circuit does not have any redundancy in the emergency-stop control circuit. Suited up to SIL2, Performance Level d, Cat. 3

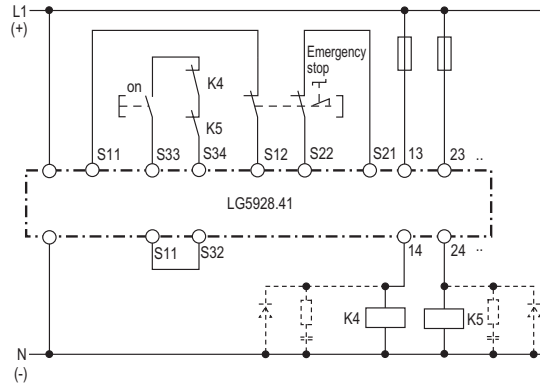

Contact reinforcement by external contactors, 2-channel controlled. The output contacts can be reinforced by external contactors with forcibly guided contacts for switching currents > 8 A e.g. 6 A. Functioning of the external contactors is monitored by looping the NC contacts into the closing circuit (terminals S13-S34 or S33-S34). Suited up to SIL3, Performance Level e, Cat. 4

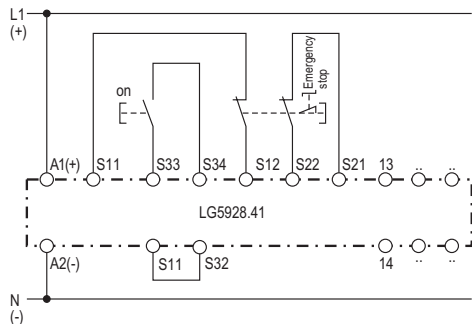

2-channel emergency stop circuit with cross fault monitoring. Suited up to SIL3, Performance Level e, Cat. 4

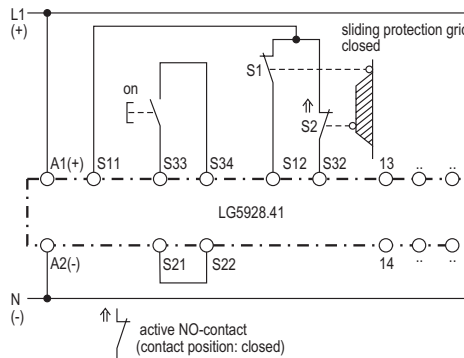

2-channel safety gate monitoring. Suited up to SIL3, Performance Level e, Cat. 4

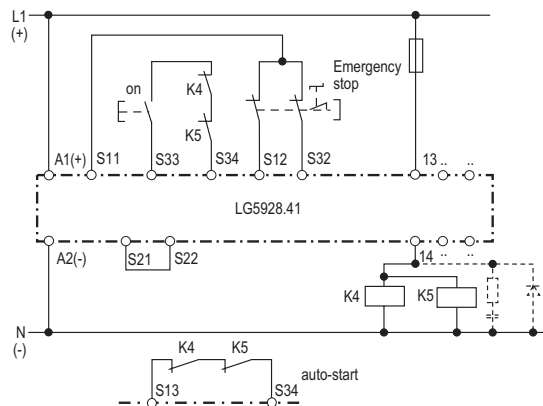

Contact reinforcement by external contactors controlled by one contact path. S33 - S34 must stay open on auto start. Suited up to SIL3, Performance Level e, Cat 4, if the external contactors are in the same cabinet and the wiring is short circuit and crossfault prove.

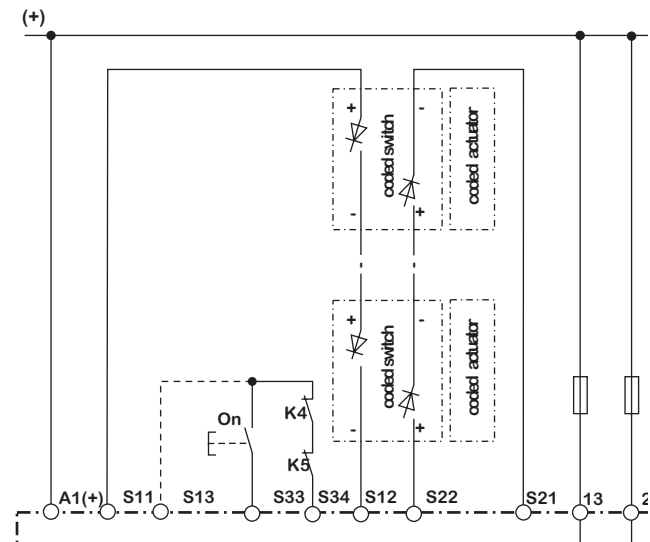

# Dold LG5928 Series – Dual Channel Safety Relay with Delay

## Curves

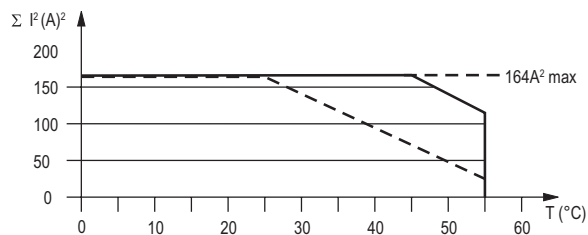
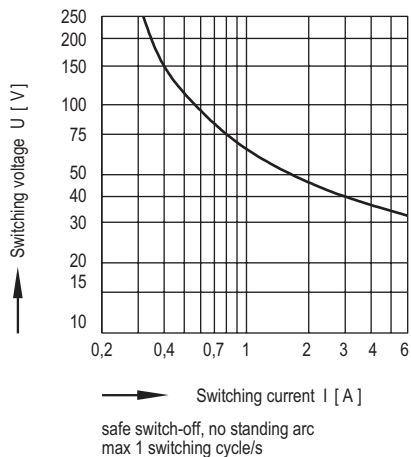

— device mounted on distance with air circulation.  
max. current at 55°C over  
3 contact rows =  $2 \times (7A)^2 + (5A)^2 = 123A^2$

- - - device mounted without distance heated by  
devices with same load.  
max. current at 55°C over  
3 contact rows =  $3 \times (3A)^2 = 27A^2$

$$\Sigma I^2 = I_1^2 + I_2^2 + I_3^2$$

$I_1, I_2, I_3$  - current in contact rows

Quadratic total current limit curve

# Dold LG5929 Extension Module



Additional contacts for emergency-stop modules and safety gate monitors.

- 1-channel or 2-channel connection
- LED indication for operation
- Output: 5 N.O. and 1 N.C. contacts

## Safety Relays Selection Chart

Part Number	Price	Marking Type	Voltage	Outputs
<b>LG5929-60-100-61</b>	\$136.00	Safety relay extension module	24 VAC/VDC	5 N.O./1 N.C.

## Safety Data – Values per EN ISO 13849-1

<b>Category</b>	<b>4 according to EN 954-1</b>
<b>Performance level</b>	PLe according to EN 13849-1
<b>MTTF<sub>d</sub></b>	>100 years
<b>DC<sub>avg</sub></b>	99%

## Safety Data – Values per IEC/EN 62061 /IEC/EN 61508

<b>SIL CL</b>	3 per IEC/EN 62061
<b>SIL</b>	3 per IEC/EN 61508
<b>HFT (Hardware Failure Tolerance)</b>	1
<b>DC<sub>avg</sub></b>	99%
<b>SFF</b>	99.7%
<b>PFH<sub>D</sub></b>	4.68E <sup>-10</sup> h <sup>-1</sup>

## Safety Relay Extension Module Specification Table

General Specifications	
<b>Temperature</b>	Storage: -25°C to 85°C (-13°F to 185°F) Operating: -15°C to 55°C (5°F to 131°F)
<b>Altitude</b>	< 2,000 meters
<b>Vibration Resistance</b>	Amplitude: 0.35mm, Frequency: 10 to 55 Hz (IEC/EN 60-068-2-6)
<b>Degree of Protection</b>	Per IEC/EN 60 529. Housing: IP40; Terminals IP20
<b>Housing</b>	UL 94V-0 Thermoplastic; Din mount 35 mm x 7.5 mm
<b>Weight</b>	205g (7.23 oz.)
<b>Agency Approvals and Standards</b>	CSA, cULus file E107778, CE, RoHS, TUV
<b>Terminal Designation per EN 50 005 Wire Connections</b>	1x4 mm <sup>2</sup> solid or 1 x 2.5 mm <sup>2</sup> stranded ferruled (isolated) or 2 x 1.5 mm <sup>2</sup> stranded ferruled (isolated) DIN 46 228-1/-2/-3/-4 or 2 x 2.5 mm <sup>2</sup> solid per DIN 46 228-1/-2/-3 /-4
<b>Wire Fixing</b>	Plus-minus terminal screws M3.5 box terminals with wire protection or cage clamp terminals.
Input Specifications	
<b>Nominal Voltage</b>	24V AC/DC
<b>Voltage Range</b>	AC: 0.85 to 1.1 U <sub>N</sub> At 10% residual ripple: 0.9 to 1.1 U <sub>N</sub> ; At 48% residual ripple: 0.85 to 1.1 U <sub>N</sub>
<b>Maximum Consumption</b>	24VAC/DC: 1.8VA
<b>Nominal Frequency</b>	50 to 60 Hz
<b>Control Current</b>	Control current typ. at 24V over 2 relays: 75 mA
<b>Overvoltage Protection</b>	Internal VDR (Voltage Dependent Resistor)
Output Specifications	
<b>Electrical Contact Life</b>	To AC15 at 2 A,230V: 10 <sup>5</sup> switching cycles IEC/EN 60 947-5-1
<b>Mechanical Life</b>	20 x 10 <sup>6</sup> switching cycles
<b>Contact Type</b>	5 N.O. positively driven and 1 N.C. relay contacts (N.O. contacts are safety contacts)
<b>Operate/Release Time</b>	Operate typ at U <sub>N</sub> : 20 ms.; Release typ at U <sub>N</sub> : 35 ms.
<b>Nominal Output Voltage</b>	250VAC
<b>Thermal Current (I<sub>th</sub>)</b>	Max. 5A per contact. See continuous current limit curve in installation manual.
<b>Short Circuit Strength</b>	Max fuse rating: 10A gl (IEC/EN 60 9470-5-1); Line circuit breaker: B6A
<b>Switching Capacity IEC/EN 60 947-5-1</b>	AC 15: N.O. contacts: 3A/230V; N.C. contacts: 2A/230VAC DC 13: N.O. contacts: 4A/24V; N.C. contacts: 4A/24VDC; N.O. contact: 8A/24V >25x10 <sup>3</sup> ON: 0.4s, OFF: 9.6s
<b>Switching Frequency</b>	Max. 1,200 switching cycles/hr

# Dold LG5929 Extension Module

## Wiring

## Dimensions mm [in]

**LG5929 Block Diagram**

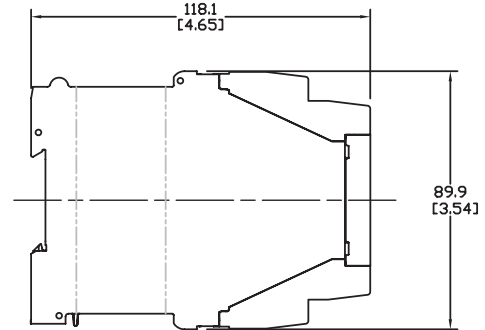
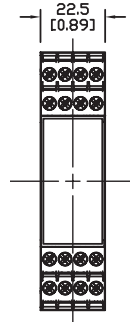
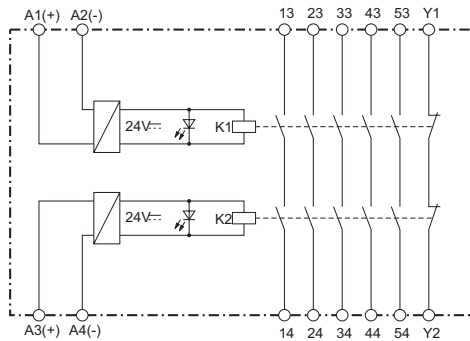

## Applications

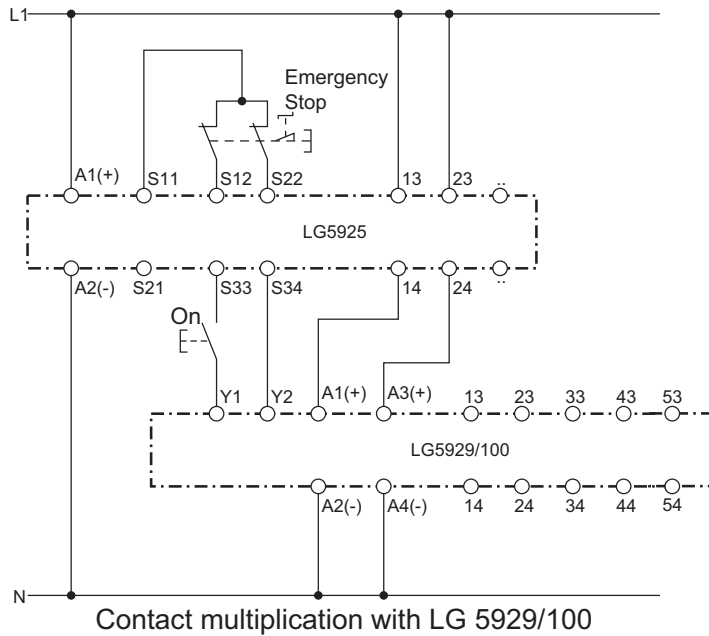

*Note: This is a representative drawing. Depending on the LG5925 safety relay you select, different voltage sources may be required.*

*\*Note: When switching inductive loads, surge suppressors are recommended.*

# Safety Products



*Warning: Safety products sold by AutomationDirect are Safety components only. The purchaser/installer is solely responsible for the application of these components and ensuring all necessary steps have been taken to assure each application and use meets all performance and applicable safety requirements and/or local, national and/or international safety codes as required by the application. AutomationDirect cannot certify that our products, used solely or in conjunction with other AutomationDirect or other vendors' products, will assure safety for any application. Any person using or applying any products sold by AutomationDirect is responsible for learning the safety requirements for their individual application and applying them, and therefore assumes all risks, and accepts full and complete responsibility, for the selection and suitability of the product for their respective application.*

*AutomationDirect does not provide design or consulting services, and cannot advise whether any specific application or use of our products would ensure compliance with the safety requirements for any application.*