

Closed Spacer Box

- Use for creating wider cable duct between network bay equipment racks
- Can be used for either left or right side
- Includes (1 each) spacer box, $\frac{3}{8}$ " x $2\frac{3}{4}$ " wedge anchor, $\frac{3}{8}$ " hex nut, $\frac{3}{8}$ " flat washer, $\frac{7}{16}$ " flat washer, and (2) #12-24 x $\frac{3}{8}$ " PHMS
- Material: 11 Ga. (3.0mm) ASTM A1011SS steel
- Finish __: Telco gray powder coat (TG)
Yellow zinc (YZ)
Other finishes are available upon request

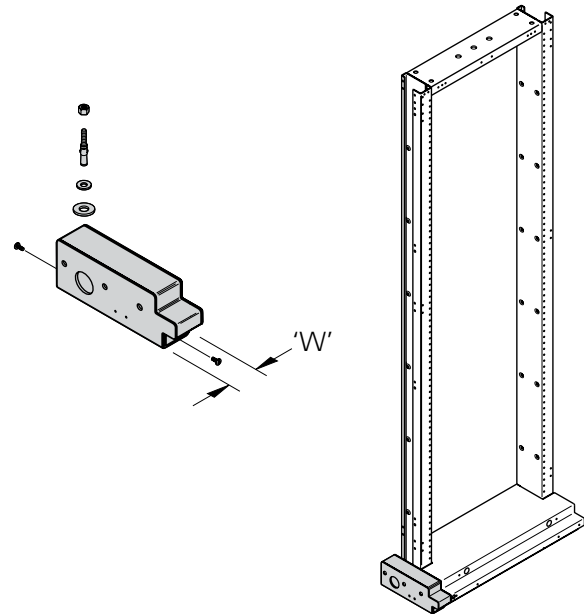

Part Number	'W' Width		Weight	
	in.	(mm)	Lbs.	(kg)
SB59152 $\frac{1}{2}$ __	2 $\frac{1}{2}$ "	(63)	5.92	(2.68)
SB59155__	5"	(127)	8.59	(3.89)

Specify part number and finish when ordering.

Rear Bumper Clip For Spacer Box

- Use to protect back side of spacer box
- Material: 14 Ga. (1.9mm) ASTM A1011CS steel
- Finish __: Telco gray powder coat (TG)
Yellow zinc (YZ)
Other finishes are available upon request

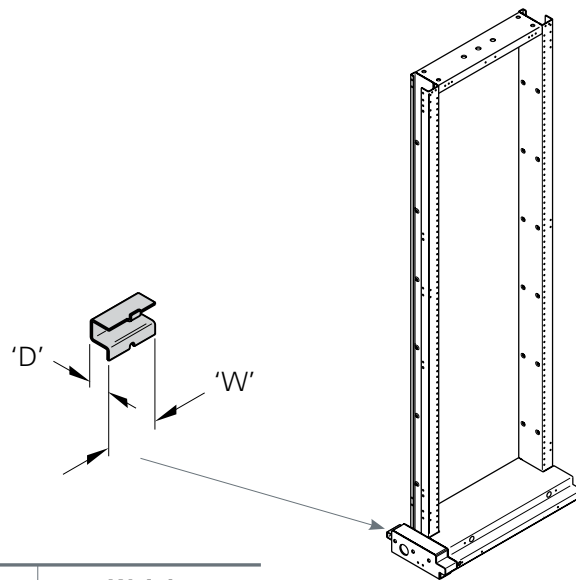

Part Number	'D' Depth		'W' Width		Weight	
	in.	(mm)	in.	(mm)	Lbs.	(kg)
SB59232 $\frac{1}{2}$ x1__	1"	(25)	2 $\frac{1}{2}$ "	(63)	0.20	(0.09)
SB59235x1__	1"	(25)	5"	(127)	0.40	(0.18)
SB59232 $\frac{1}{2}$ x2__	2"	(51)	2 $\frac{1}{2}$ "	(63)	0.32	(0.14)
SB59235x2__	2"	(51)	5"	(127)	0.65	(0.29)

Specify part number and finish when ordering.