

Strut joiners

B766 Series Straight Strut Joiner

- Includes: 2 Cam screws
- Material: 12 gauge (2.6)
- Standard finish: ZN

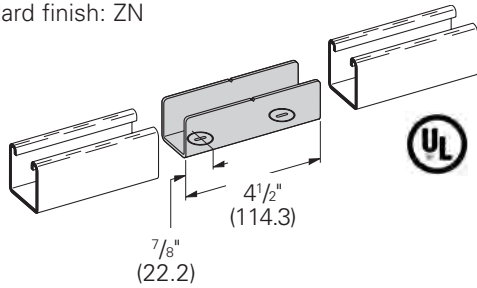

Part No.	For Channel Size	Wt./C	
		Lbs.	kg
B766-11	B11	94	(42.6)
B766-12	B12	72	(32.6)
B766-22 *	B22 & B24	50	(22.7)
B766-32	B32	44	(19.9)
B766-42	B42	34	(15.4)
B766-52	B52 & B54	28	(12.7)

* Cast aluminum parts

B767 Series 90° Elbow Strut Joiner

- Includes: 2 Cam screws
- Material: 12 gauge (2.6)
- Standard finish: ZN

Note: B767-22
(Cast Aluminum Fitting)
does not require miter
cutting of channel as
shown in drawing.

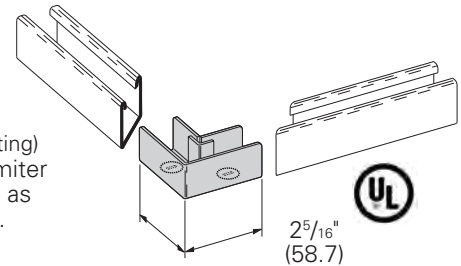

Part No.	For Channel Size	Wt./C	
		Lbs.	kg
B767-11	B11	74	(33.5)
B767-12	B12	56	(25.4)
B767-22 *	B22 & B24	39	(17.7)
B767-32	B32	34	(15.4)
B767-42	B42	27	(12.2)
B767-52	B52 & B54	23	(10.4)

* Cast aluminum parts

B768 Series Tee Strut Joiner

- Includes: 3 Cam screws
- Patented
- Material: 12 gauge (2.6)
- Standard finish: ZN

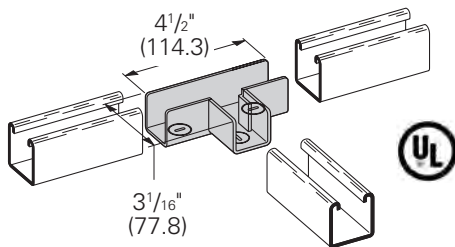

Part No.	For Channel Size	Wt./C	
		Lbs.	kg
B768-11	B11	142	(64.4)
B768-12	B12	112	(50.8)
B768-22 *	B22 & B24	79	(35.8)
B768-32	B32	72	(32.6)
B768-42	B42	62	(28.1)
B768-52	B52 & B54	57	(25.8)

* Cast aluminum parts

B769 Series Cross Strut Joiner

- Includes: 4 Cam screws
- Patented
- Material: 12 gauge (2.6)
- Standard finish: ZN

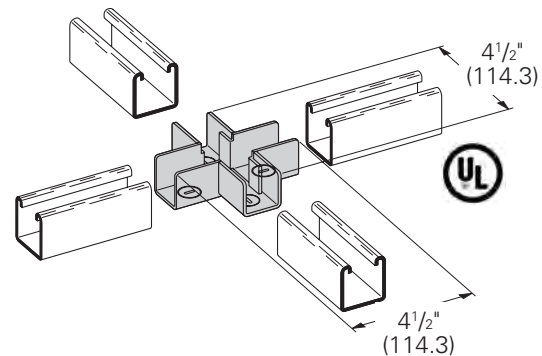

Part No.	For Channel Size	Wt./C	
		Lbs.	kg
B769-11	B11	148	(67.1)
B769-12	B12	120	(54.4)
B769-22 *	B22 & B24	87	(39.4)
B769-32	B32	78	(35.4)
B769-42	B42	65	(29.5)
B769-52	B52 & B54	58	(26.3)

* Cast aluminum parts

Note: Strut joiners are not for structural support. A channel support is recommended within 24" (609 mm) of each joint.

Reference page 206 for general fitting and standard finish specifications. U.L. Wire Fill Chart on pages 272 - 273.