

Introduction

Our strut support system is designed with many time-saving features. They are fully adjustable and reusable, with a complete line of channels, fittings and accessories for multi-purpose applications.

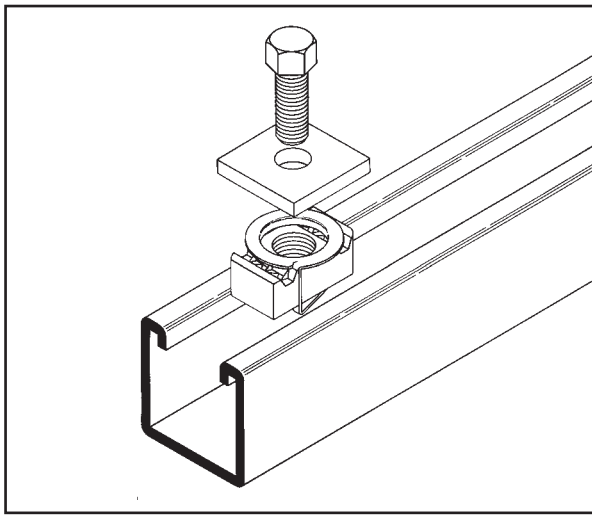

- **No Welding**
- **No Drilling**
- **Use Your Imagination**

The strut system installs quickly, with no need for special tools. All you need is a wrench and hacksaw.

Channels and parts can be taken apart for reuse as quickly as they were assembled, yet help provide the strength of welded construction. This eliminates welding and drilling which can have substantial savings in time and labor.

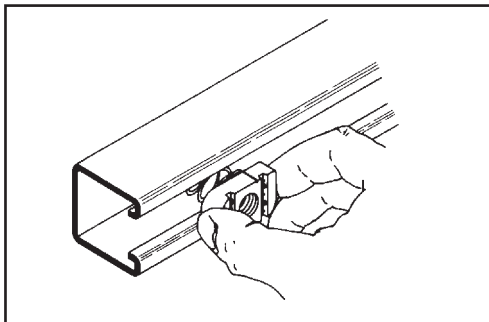

1. **Channel nut may be inserted anywhere along continuous slot. Designed for easy insertion and self-alignment.**

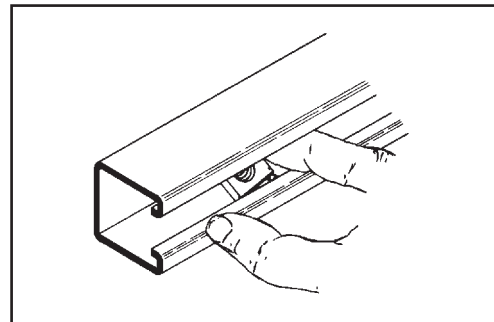

2. **A 90° turn aligns channel nut grooves with inturned lips of the channel.**

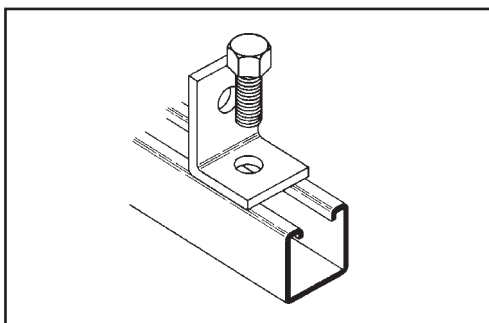

3. **Position fitting over channel nut and insert bolt to start any connection.**

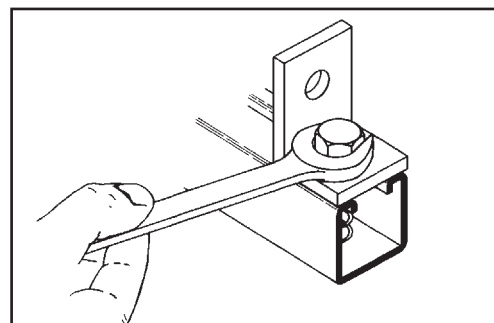

4. **With the twist of a wrench, channel nut locks its teeth firmly against inturned lips.**

Our strut system provides an economical solution for electrical, mechanical and industrial supports with an unlimited variety of applications in the construction industry.

Electrical Applications

- Lighting Fixture Supports
- Raceway Systems
- Trapeze Hangers
- Pipe & Conduit Supports
- Cable Tray Supports
- Beam Adjustments

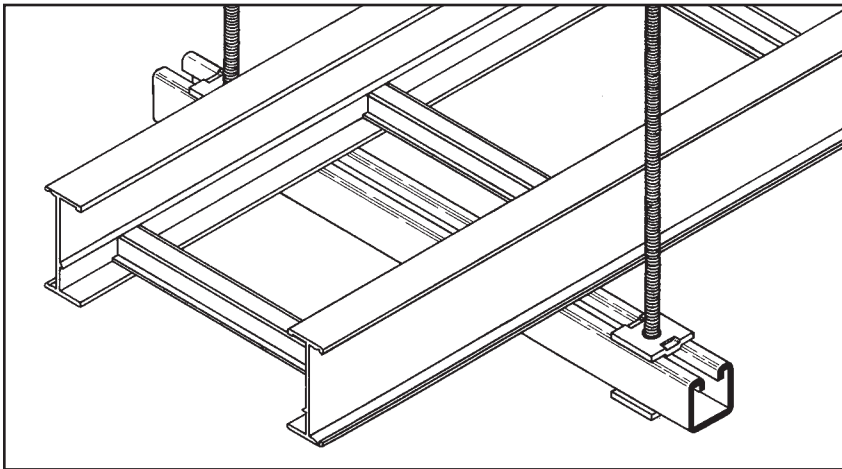
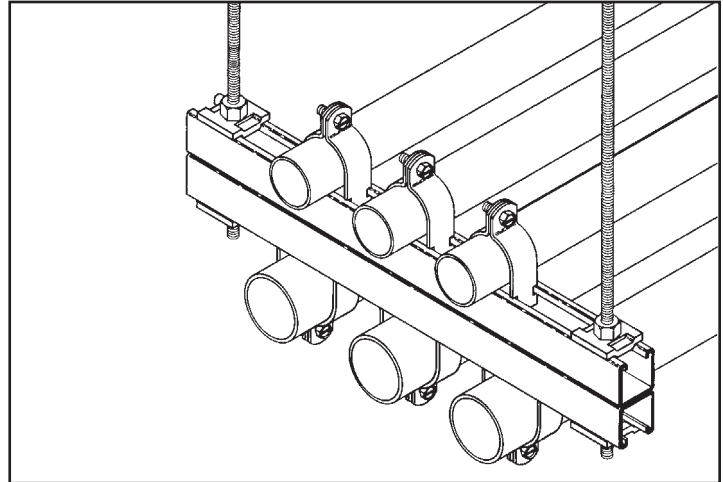

Mechanical Applications

- Piping Racks
- Tunnel Pipe Stanchions
- Concrete Inserts
- Beam Attachments
- Pipe Risers

Industrial Applications

- Racks and Shelving
- Partitions
- Production Line Supports
- Trolley Systems
- Wall Framing

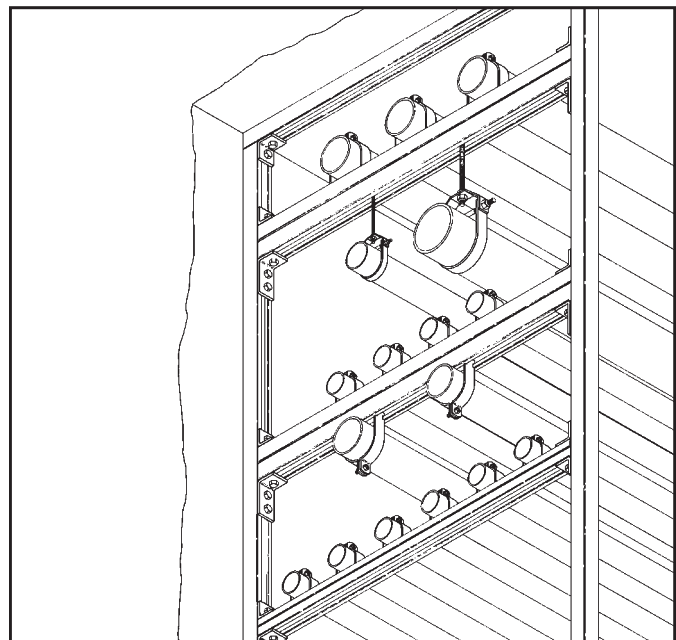

Technical Data

Materials

Carbon Steel

Channels made from high-quality carbon steel are continuously roll formed to precise dimensions. By cold working the steel mechanical properties are increased, allowing lightweight structures to carry the required load. Corrosion resistance of carbon steel varies widely with coating and alloy. See "Finishes" for more detailed information.

Stainless Steel

Stainless steel channel is available in AISI Type 304 or 316 material. Both are non-magnetic and belong to the austenitic stainless steels group, based on alloy content and crystallographic structure. Like carbon steel, stainless steel exhibits increased strength when cold worked by roll-forming.

Several conditions make the use of stainless steel ideal. These include reducing long term maintenance costs, high ambient temperatures, appearance, and stable structural properties such as yield strength, and high creep strength.

Type 304 resists most organic chemicals, dyestuffs and a wide variety of inorganic chemicals at elevated or cryogenic temperatures. Type 316 contains slightly more nickel and adds molybdenum to give it better corrosion resistance in chloride and sulfuric acid environments. For more information concerning the differences between types 304 and 316, visit www.bline.com.

Aluminum

Standard aluminum channel is extruded from aluminum alloy 6063-T6. Strut fittings are made from aluminum alloy 5052-H32.

The high strength to weight ratio of channel made of aluminum helps greatly reduce the overall cost of installation through ease of handling and field cutting.

Aluminum owes its excellent corrosion resistance to its ability to form an aluminum oxide film that immediately reforms when scratched or cut. In most outdoor applications, aluminum has excellent resistance to "weathering". The resistance to chemicals, indoor or outdoor, can best be determined by tests conducted by the user with exposure to the specific conditions for which it is intended. The corrosion resistance of aluminum to some commonly known chemicals is shown in the Corrosion Chart on page 10. For further information, contact us or the Aluminum Association.

Fiberglass

We offer two fire retardant (FR) resins for strut systems, polyester and vinyl ester. Both resins are ideal for corrosive environments or nonconductive applications with moderate strength requirements. Some common types of environments where Vinyl Ester Resins are recommended, that Poly Esters are not, are paper mills, most any metal plating operation and any condition with

concentrated levels of Chlorine, [Cl⁻]. Please consult our fiberglass corrosion resistance charts on page 184 for specific chemical recommendation data.

Unlike other base materials depicted in this catalog, fiberglass exhibits unique physical property changes when operating in elevated temperature conditions that are a fraction of increase compared to steel or aluminum. Thus, it is advised against using fiberglass in temperatures greater than 200° F.

Please refer to the "Corrosion Resistance Guide" on page 184 for specific applications.

The fiberglass strut systems are manufactured from glass fiber-reinforced plastic shapes that meet ASTM E-84, Class 1 Flame Rating and self-extinguishing requirements of ASTM D-635. A surface veil is applied during pultrusion to insure a resin-rich surface and ultraviolet resistance.

While polyester is sufficient for most uses, vinyl ester is suitable for a broader range of environments.

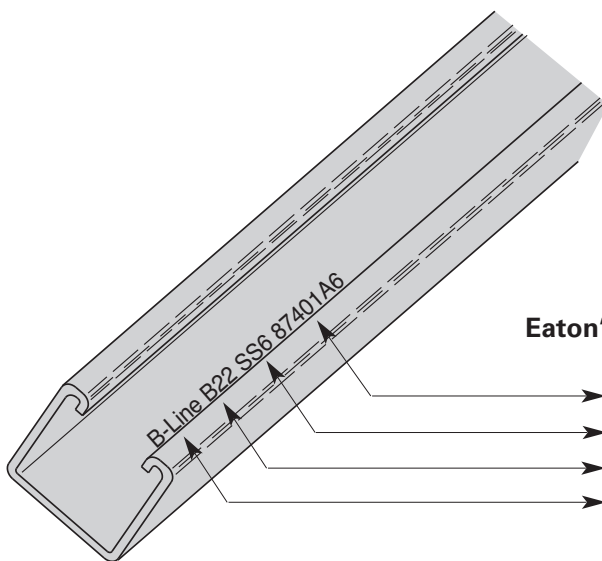

Eaton's B-Line Series Steel Strut is stamped with:

- Traceable to the steel's origin
- Material/Finish
- Part number designation
- Company Name

Finishes

Zinc Coatings

Zinc protects steel in two ways. First it protects the steel as a coating, and second acts as a sacrificial anode to repair bare areas such as cut edges, scratches, and gouges. The corrosion protection of zinc is directly related to its thickness and the environment. This means a .2 mil coating will last twice as long as a .1 mil coating in the same environment.

Galvanizing also protects cut and drilled edges.

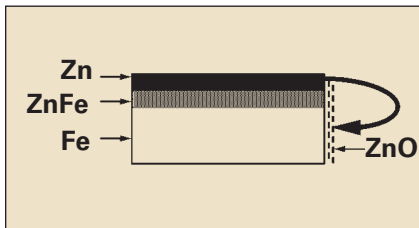

Electrogalvanized Zinc

Electrogalvanized Zinc (also known as zinc plated or electroplated) is the process by which a coating of zinc is deposited on the steel by electrolysis from a bath of zinc salts.

A rating of SC3, our standard, provides a minimum zinc coating thickness of .5 mils (excluding hardware, which is SC1 = .2 mils).

When exposed to air and moisture, zinc forms a tough, adherent, protective film consisting of a mixture of zinc oxides, hydroxides, and carbonates. This film is a barrier coating which helps slow subsequent corrosive attack on the zinc. This coating is usually recommended for indoor use in relatively dry areas, as it provides ninety-six hours protection in salt spray testing per ASTM B117.

Chromium / Zinc

Chromium / Zinc is a corrosion resistant composition, which was developed to protect fasteners and small bulk items for automotive use. The coating applications have since been extended to larger parts and other markets.

Chromium/Zinc composition is an aqueous coating dispersion containing chromium, proprietary organics, and zinc flake.

This finish provides 720 hours protection in salt spray testing per ASTM B117.

Pre-Galvanized Zinc

(Mill galvanized, hot dip mill galvanized or continuous hot dip galvanized) Pre-galvanized steel is produced by coating coils of sheet steel with zinc by continuously rolling the material through molten zinc at the mills. This is also known as mill galvanized or hot dip mill galvanized. These coils are then slit to size and fabricated by roll forming, shearing, punching, or forming to produce our pre-galvanized strut products.

The G90 specification calls for a coating of .90 ounces of zinc per square foot of steel. This results in a coating of .45 ounces per square foot on each side of the sheet. This is important when comparing this finish to hot dip galvanized after fabrication.

During fabrication, cut edges and welded areas are not normally zinc coated; however, the zinc near the uncoated metal becomes a sacrificial anode to protect the bare areas after a short period of time.

Hot Dip Galvanized After Fabrication (Hot dip galvanized or batch hot dip galvanized)

Hot dip galvanized strut products are fabricated from steel and then completely immersed in a bath of molten zinc. A metallic bond occurs resulting in a zinc coating that completely coats all surfaces, including edges and welds.

Another advantage of this method is coating thickness. Strut products that are hot dip galvanized after fabrication have a minimum thickness of 1.50 ounces per square foot on each side, or a total 3.0 ounces per square foot of steel, according to ASTM A123.

The zinc thickness is controlled by the amount of time each part is immersed in the molten zinc bath as well as the speed at which it is removed. The term "double dipping" refers to parts too large to fit into the galvanizing kettle and must be dipped one end at a time. It does not refer to extra coating thickness.

The layer of zinc which bonds to steel provides a dual protection against corrosion. It protects first as an overall barrier coating. If this coating happens to be scratched or gouged, zinc's secondary defense is called upon to protect the steel by galvanic action.

Hot-Dip Galvanized After Fabrication is recommended for prolonged outdoor exposure and will usually protect steel for 20 years or more in most atmospheric environments and in many industrial environments. For best results, a zinc rich paint (available from Eaton's B-Line Division) should be applied to field cuts. The zinc rich paint will provide immediate protection for these areas and eliminate the short time period for galvanic action to "heal" the damaged coating.

Anticipated Life of Zinc Coatings In Various Atmospheric Environments

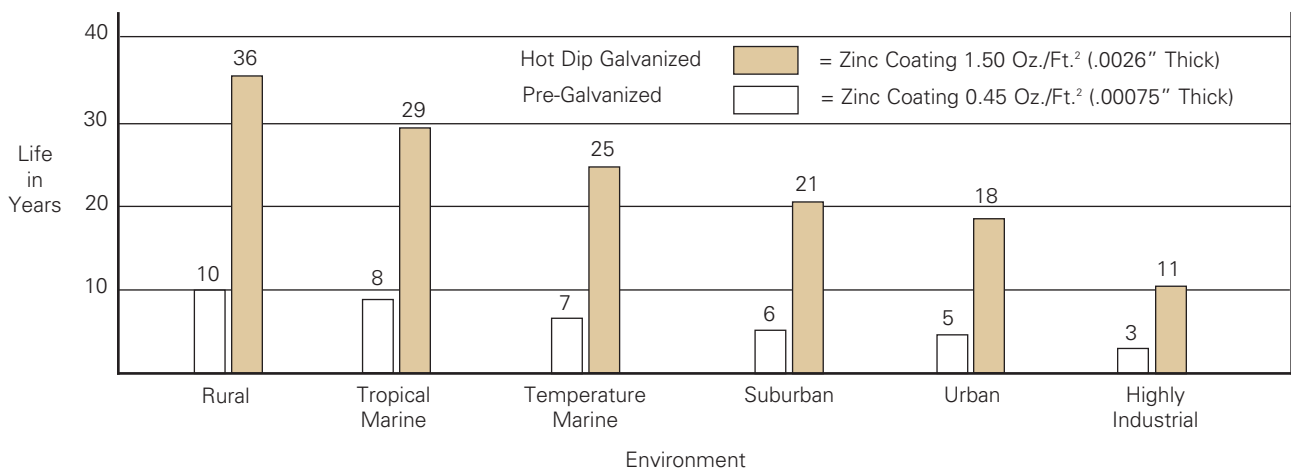

Technical Data

DURA GREEN™ and DURA-COPPER™ Epoxy Coatings

DURA GREEN and DURA-COPPER epoxy coatings are water borne epoxy coatings applied to B-Line series products by a precisely controlled cathodic electro-deposition process. This process is accomplished using a conveyor to transport channel and fittings through several cleaning, phosphatizing and application stages prior to being baked (See diagram below).

This custom-designed paint system is used for painting all channels, channel combinations, slotted angle, and fittings.

Samples are selected on a routine basis for salt spray (fog) testing to verify the quality of the finish. These tests are performed in accordance with ASTM B117 and evaluated and related according to ASTM D1654 (Tables 1 & 2).

The DURA GREEN and DURA-COPPER epoxy coatings have been tested and listed by Underwriters Laboratories in

accordance with "Standard for Surface Metal Raceway and Fittings, UL5" and "Standard for Pipe Hanger Equipment for Fire Protection Service, UL203".

Due to DURA GREEN's organically based composition, it seats itself into porous surfaces more completely and efficiently than zinc coatings. As these porous caverns are filled along the material profile, the outer finished surface demonstrates an increased smooth uniform plane which produces considerably less off-gasing when tested.

DURA GREEN channel meets or exceeds 100 level clean room standards. This was confirmed by testing the channel in accordance with Boeing (PCL) Standards, which are more stringent and complete than ASTM E595-93. DURA GREEN was found to be a superior finish, due in part to its proven application process.

Technical Data

Salt Spray Test Results

Type of Finish	Unscribed 5% Failure (1)	Scribed 1/8" (3.2) Creepage from Scribe (1)
DURA GREEN Epoxy	1000 Hours	312 Hours
Mill Galv. (Pre-Galv.) G90	192 Hours	288 Hours
Perma-Green	438 Hours	231 Hours
Zinc Chromate	36 Hours	96 Hours
Industry Green (Range)	10 to 36 Hours	4 to 30 Hours

(1) All salt spray (fog) tests conducted in accordance with ASTM B117 and evaluated and rated according to ASTM D1654 Tables 1 & 2. Tests are performed and certified by an independent testing laboratory.

DURA GREEN / DURA-COPPER Epoxy Coating Process

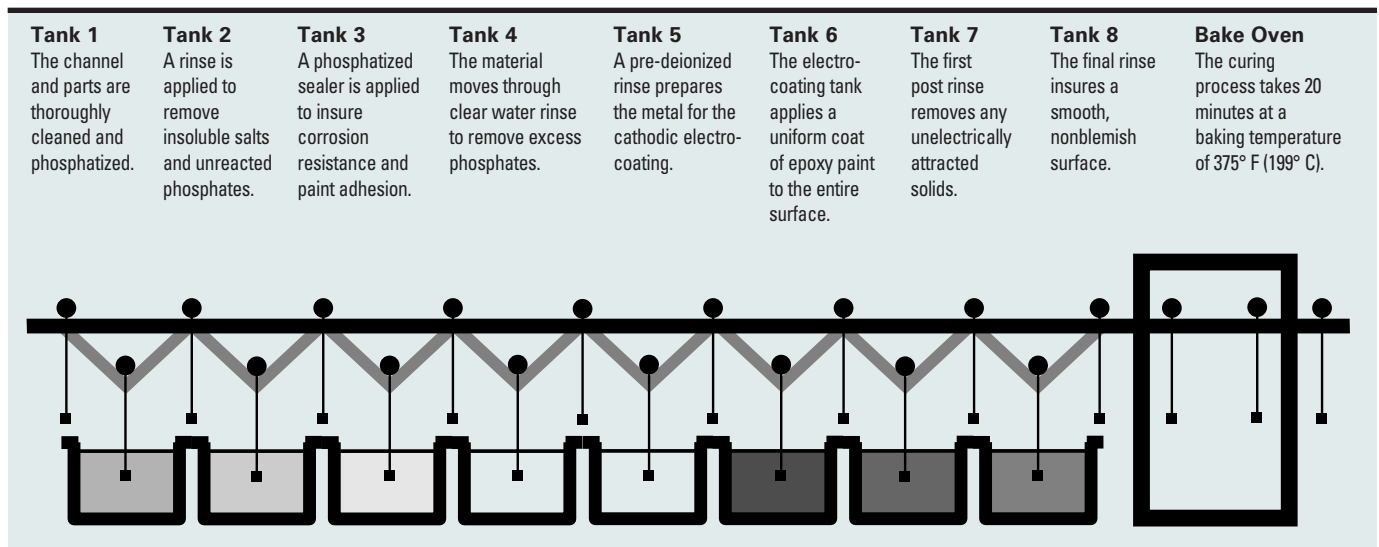

Welding

The welding procedures used in the fabrication of our steel products are in accordance with American Welding Society (AWS) Standards. To help achieve the highest quality in our manufacturing processes, our welders follow standards set by AWS Code.

Spot Welding

Spot welded back-to-back channel is manufactured using a modern DC powered resistance welder controlled by a microprocessor. This produces a series of spot welds with speed and consistency.

Consistency is one of the most important advantages in specifying back-to-back channel. Variables such as weld

sequence, speed and duration are carefully controlled and monitored by a sophisticated electronic control system. A statistical quality control program, combining destructive and non-destructive testing, is used to help ensure high quality welds.

MIG Welding

MIG welded, more properly called gas metal arc welded (GMAW) combination channels and fittings, are produced when physical dimensions or certain combinations require a weld process other than automatic spot welding. The same quality control requirements are imposed on MIG welded and spot-welded products.

Quality Assurance

Our Quality Assurance Program has been developed and implemented for compliance with ISO9001:2008. We also comply with various industry standards and specifications. We have extensive experience in supplying metal framing components for the nuclear power generating industry, and upon request can provide products in compliance with 10CFR50 Appendix B, NQA-1 and 10CFR21. For more information on our quality capability please visit www.cooperblineline.com/nuclear.

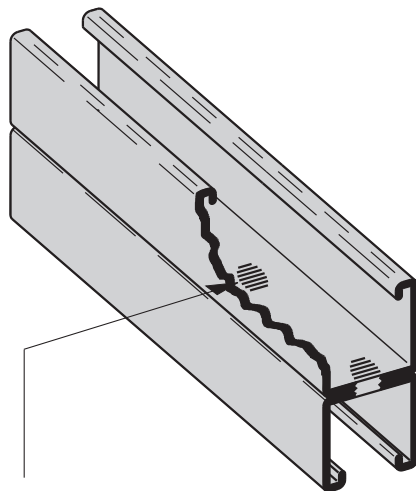

Spot Weld

1/2" (12.7mm) spot welds every
4" (101.6mm) on center

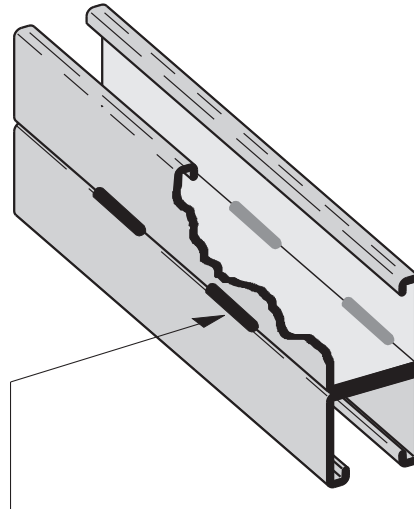

MIG Weld

3/4" (9.0mm) long MIG welds every
6" (152.4mm) on center

Corrosion

All metal surfaces are affected by corrosion. Depending on the physical properties of the metal and the environment to which it is exposed, chemical or electromechanical corrosion may occur.

Atmospheric Corrosion

Atmospheric corrosion occurs when metal is exposed to airborne liquids, solids or gases. Some sources of atmospheric corrosion are moisture, salt, dirt and sulphuric acid. This form of corrosion is typically more severe outdoors, especially near marine environments.

Chemical Corrosion

Chemical corrosion takes place when metal comes in direct contact with a corrosive solution. Some factors which affect the severity of chemical corrosion include: chemical concentration level, duration of contact, frequency of washing, and operating temperature.

Storage Corrosion

Wet storage stain (white rust) is caused by the entrapment of moisture between surfaces of closely packed and poorly ventilated material for an extended period. Wet storage stain is usually superficial, having no affect on the properties of the metal.

Light staining normally disappears with weathering. Medium to heavy buildup should be removed in order to allow the formation of normal protective film. Proper handling and storage will help to assure stain-free material. If product arrives wet, it should be unpacked and dried before storage. Dry material should be stored in a well ventilated "low moisture" environment to avoid condensation formation. Outdoor storage is undesirable, and should be avoided whenever possible.

Galvanic Corrosion

Galvanic corrosion occurs when two or more dissimilar metals are in contact in the presence of an electrolyte (i.e.: moisture). An electrolytic cell is created and the metals form an anode or a cathode depending on their relative position on the Galvanic Series Table. The anodic material will be the one to corrode. Anodic or cathodic characteristics of two dissimilar metals will depend on the type of each material. For example: If zinc and steel are in contact, the zinc acts as the anode and will corrode; the steel acts as the

Galvanic Series in Sea Water

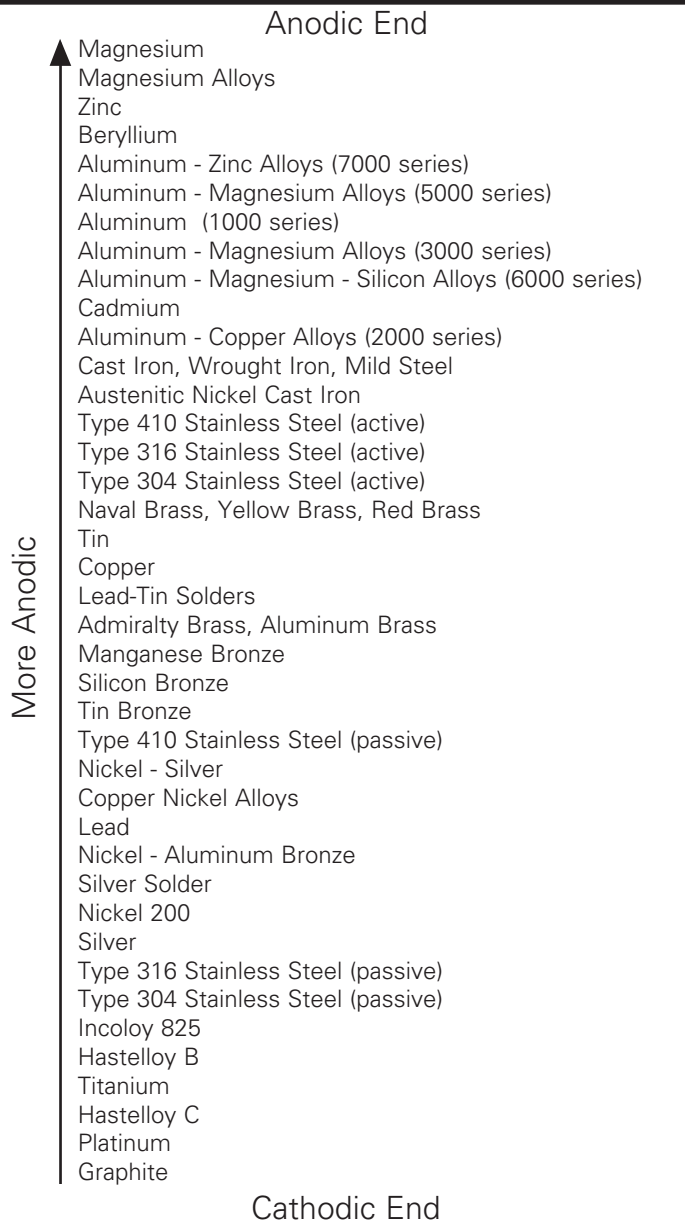

Metals in descending order of activity in the presence of an electrolyte.

cathode, and will be protected. If steel and copper are in contact, the steel is now the anode and will corrode.

The rate at which galvanic corrosion occurs depends on several factors:

1. The relative position on the Galvanic Series Table - the further apart materials are in the Galvanic Series Table, the greater the potential for corrosion of the anodic material.

2. The amount and concentration of electrolyte present - an indoor, dry environment will have little or no galvanic corrosion compared to a wet atmosphere.

3. The relative size of the materials - a small amount of anodic material in contact with a large cathodic material will result in greater corrosion. Likewise, a large anode in contact with a small cathode will decrease the rate of attack.

Chemical	Aluminum	DURA GREEN™	PVC	Type 304 Stainless	Type 316 Stainless	Zinc Coated Steel
Acetic Acid 10%	R	NR	R	R	R	NR
Acetic Acid 2%	R	F	R	R	R	NR
Acetone	R	R	NR	R	R	R
Ammonium Hydroxide-Conc.	R	R	R	R	R	-
Ammonium Hydroxide 10%	F	R	R	R	R	-
Ammonium Hydroxide 2%	R	R	R	R	R	-
Benzene	R	R	NR	R	R	-
Bromine Water	NR	R	R	NR	NR	-
Butanol (Butyl Alcohol)	R	R	R	R	R	R
Carbon Disulfide	R	R	NR	R	R	-
Carbon Tetrachloride	F	R	F	R	R	-
Chlorine Water	R	R	R	NR	F	R
Cutting Oil	-	R	-	-	-	-
Diethanolamine	R	R	NR	-	-	NR
Ethanol	R	R	R	R	R	R
Ethyl Acetate	R	R	NR	-	-	R
Ethylene Dichloride	F	R	NR	-	-	R
Formaldehyde 20%	R	R	R	R	R	R
Gasoline	R	R	R	R	R	R
Glycerine	R	R	R	R	R	R
Household Detergent 10%	F	R	R	R	R	-
Hydrochloric Acid 40%	NR	NR	R	NR	NR	NR
Hydrochloric Acid 10%	NR	F	-	NR	NR	NR
Hydrochloric Acid 2%	NR	F	-	NR	NR	NR
Hydrogen Peroxide 30%	R	NR	R	R	R	-
Hydrogen Peroxide 3%	R	R	-	R	R	-
Hydrogen Sulfide (Gas)	R	R	R	F	R	-
JP-4 Jet Fuel	R	R	R	R	R	-
Lactic Acid 85%	F	R	R	NR	-	-
Latex	R	R	-	R	R	NR
Linseed Oil Fatty Acid	R	F	R	R	R	-
Methanol	R	R	R	R	R	R
Methyl Ethyl Ketone	R	R	NR	-	-	R
Methyl Isobutyl Ketone	R	R	NR	-	-	R
Mineral Spirits	R	R	-	-	-	-
Motor Oil-10W	R	R	R	R	R	R
Naphtha, VM&P	R	R	R	R	R	R
Nitric Acid 2%	F	NR	R	R	R	-
Perchloroethylene	R	R	-	-	-	NR
Petroleum Ether	-	R	-	R	R	R
Phenol 10%	R	R	NR	R	R	R
Phosphoric Acid 2%	F	NR	R	R	R	NR
Potassium Hydroxide 50%	NR	R	R	R	R	-
Potassium Hydroxide 10%	NR	R	R	R	R	-
Potassium Hydroxide 2%	NR	R	R	R	R	-
Sodium Chloride 25%	F	R	R	R	R	F
Sodium Hydroxide 50%	NR	R	R	R	R	NR
Sodium Hydroxide 10%	NR	R	R	R	R	F
Sodium Hydroxide 2%	NR	R	R	-	-	-
Sodium Hypochlorite-C1. 10%	F	R	R	-	-	-
Sodium Hypochlorite-C1. 6%	F	R	R	NR	R	-
Sulfuric Acid 2%	F	NR	R	NR	R	NR
Tall Oil Fatty Acid (Syfate 94)	R	R	R	-	-	-
Tannic Acid 50%	F	R	R	R	R	-
Water-Deionized	R	R	R	R	R	F
Water-Sea	F	F	R	R	R	F
Water-Tap	R	R	R	F	F	R
Xyol	R	R	NR	-	-	-

For fiberglass corrosion chart see page 225.

The corrosion data given in this table is for general comparison only.

The presence of contaminants and the effect of temperature in chemical environments can greatly affect the corrosion of any material. We strongly suggest that field service tests or simulated laboratory tests using actual environmental conditions be conducted in order to determine the proper materials and finishes to be selected.

R=Recommended

F=May be used under some conditions

NR=Not Recommended

-Information not available

Design of B-Line series Strut Systems

Beams

Beams are usually defined as horizontal members which are subjected to vertical loads such as shelves, platforms or supports for pipes, conduits or cable trays.

The following is a brief overview of common beam configurations:

Simple Beam

An example of a simple beam is a length of channel placed across two cylinders. When a load is applied, the channel will support the load because of its stiffness. The cylinders serve to support the channel, but do not interfere with its natural tendency to flex or bend. Simple beam analysis is used almost universally for beam comparisons, even though it is seldom practical in field installations.

A cable tray or conduit trapeze hanger closely resembles a simple beam.

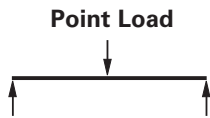

Fixed Beam

This type of fixed support restricts the movement of the ends of the channel when a load is applied. Because of this, the stiffness of the channel at the ends and center is employed to resist the load. The result is a load capability which is greater than that of an identical simple beam.

The fixed beam can be approximated by bolting or welding a length of channel to rigid supports.



Cantilever Beam

Cantilever beams are often viewed as variations of a fixed beam, but they have special characteristics of their own. One end of the channel is firmly attached to a rigid support while the other end remains completely free.

A shelf bracket is an example of a cantilever beam.



Continuous Beam

This beam configuration is commonly used in lighting installations. The continuous beam possesses traits of both the simple and fixed beams. When equal loads are applied to all spans simultaneously, the counter-balancing effect of the loads on both sides of a support restricts the movement of the channel at the support, similar to that of the fixed beam. The end spans behave substantially like simple beams.

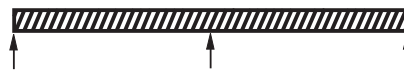

Continuous beam installations can typically support 20% more load than a simple beam of the same span with approximately half the deflection.

Therefore, simple beam data should be used for a general comparison only. An example of this configuration is found in a long run of channel when installed across several supports to form a number of spans.

Deflection

Deflection, commonly referred to as "sag", is inherent in applying a load to a beam and cannot be avoided. Any and all beams will deflect when loaded. The amount of deflection will vary depending upon the material and the stiffness or moment of inertia. The deflection equations in this section show that increasing the stiffness can be increased by a variety of methods. Increasing the depth of the channel is the most direct method.

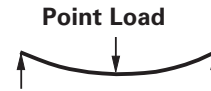

The material used affects deflection in a manner which is significantly different from the way in which it affects load capacity. The deflection under load is inversely proportional to a material property known as the "modulus of elasticity" designated by "E".

The modulus of elasticity is dependent upon the basic composition of the material and is not necessarily related to the material's strength.

Metal Framing Channels

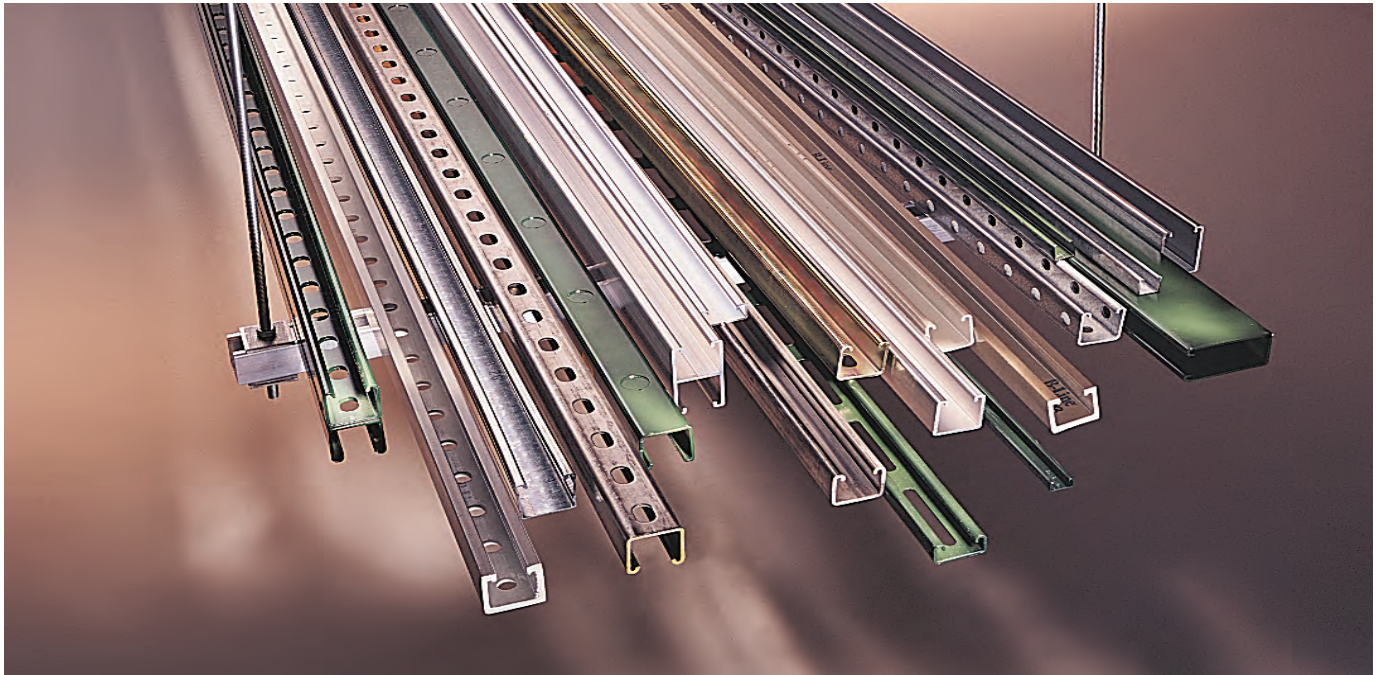

Channel

Metal framing channel is cold formed on our modern rolling mills from 12 Ga. (2.6mm), 14 Ga. (1.9mm), and 16 Ga. (1.5mm) low carbon steel strips. A continuous slot with inturned lips provides the ability to make attachments at any point.

Lengths & Tolerances

All channels excluding 'SH' style $\pm 1/8"$ (3.2mm) on 10' (3.05m) and $\pm 3/16"$ (4.76mm) on 20' (6.09m)

All 'SH' channels only $\pm 1/4"$ (6.35mm) on 10' (3.05m) and $\pm 1/2"$ (12.70mm) on 20' (6.09m)

Custom lengths are available upon request.

Slots

Slotted series of channels offer full flexibility. A variety of pre-punched slot patterns eliminate the need for precise field measuring for hole locations. Slots offer wide adjustments in the alignment and bolt sizing.

Holes

A variety of pre-punched $9/16"$ (14.3 mm) diameter hole patterns are available in our channels. These hole patterns provide an economical alternative to costly field drilling required for many applications.

Knockouts

When used with series B217-20 Closure Strips, knockout channels can be used to provide an economical U.L. listed surface raceway. Channels are furnished with $7/8"$ (22.2 mm) knockouts on 6" (152 mm) centers, allowing for perfect fixture alignment on spans up to 20' (6.09 m).

Materials & Finishes (Unless otherwise noted)

Steel: Plain & Pre-galvanized

12 Ga. (2.6), 14 Ga. (1.9) and 16 Ga. (1.5)

Note: A minimum order may apply on special material and finishes.

Design Load (Steel & Stainless Steel)

The design loads given for strut beam loads are based on a simple beam condition using an allowable stress of 25,000 psi. This allowable stress results in a safety factor of 1.68. This is based upon virgin steel minimum yield strength of 33,000 psi cold worked during rolling to an average yield stress of 42,000 psi. For aluminum channel loading multiply steel loading by a factor of 0.38.

Welding







Weld spacing is maintained between 2 $1/2$ inches (63.5 mm) and 4 inches (101.6 mm) on center. Through high quality control testing of welded channels and continuous monitoring of welding equipment, we provide the most consistent combination channels available today.

Metric

Metric dimensions are shown in parentheses. Unless noted, all metric dimensions are in millimeters.

Finish Code	Finish	Specification
PLN	Plain	ASTM A1011, 33,000 PSI min. yield
GRN	DURA GREEN™	
GLV	Pre-Galvanized	ASTM A653 33,000 PSI min. yield
HDG	Hot-Dipped Galvanized	ASTM A123
YZN	Yellow Zinc Chromate	ASTM B633 SC3 Type II
SS4	Stainless Steel Type 304	ASTM A240
SS6	Stainless Steel Type 316	ASTM A240
AL	Aluminum	Aluminum 6063-T6

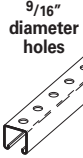
Selection Chart for Channels, Materials and Hole Patterns

Channel Type	Channel Dimensions		Material & Thickness * Stainless Steel				Channel Hole Pattern **				
	Height	Width	Steel	Alum.	Type 304	Type 316	SH	S	H17/8	TH	KO6
			<u>1</u>	<u>2</u>	<u>3</u>	<u>4</u>					
B11	3 1/4" (82.5)	1 5/8" (41.3)	12 Ga.	.105	–	–	<u>1</u>	<u>1</u>	<u>1</u>	–	<u>1</u>
B12	2 7/16" (61.9)	1 5/8" (41.3)	12 Ga.	.105	–	–	<u>1 2</u>	<u>1</u>	<u>1 2</u>	–	<u>1 2</u>
B22	1 5/8" (41.3)	1 5/8" (41.3)	12 Ga.	.105	12 Ga.	12 Ga.	<u>1 2 3 4</u>	<u>1 3</u>	<u>1 2 3 4</u>	<u>1</u>	<u>1 2</u>
B24	1 5/8" (41.3)	1 5/8" (41.3)	14 Ga.	.080	14 Ga.	14 Ga.	<u>1 2 3 4</u>	<u>1</u>	<u>1 2 3 4</u>	–	<u>1 2</u>
B26	1 5/8" (41.3)	1 5/8" (41.3)	16 Ga.	–	–	–	<u>1</u>	<u>1</u>	<u>1</u>	–	<u>1</u>
B32	1 3/8" (34.9)	1 5/8" (41.3)	12 Ga.	–	12 Ga.	–	<u>1 3</u>	<u>1</u>	<u>1 3</u>	–	<u>1</u>
B42	1" (25.4)	1 5/8" (41.3)	12 Ga.	–	12 Ga.	–	<u>1 3</u>	<u>1</u>	<u>1 3</u>	–	<u>1</u>
B52	1 3/16" (20.6)	1 5/8" (41.3)	12 Ga.	–	12 Ga.	12 Ga.	<u>1 3 4</u>	<u>1</u>	<u>1</u>	–	<u>1</u>
B54	1 3/16" (20.6)	1 5/8" (41.3)	14 Ga.	.080	14 Ga.	14 Ga.	<u>1 2 3 4</u>	<u>1</u>	<u>1 2 3 4</u>	–	<u>1 2</u>
B56	1 3/16" (20.6)	1 5/8" (41.3)	16 Ga.	–	–	–	<u>1</u>	<u>1</u>	<u>1</u>	–	<u>1</u>
B62	1 3/16" (20.6)	1 3/16" (20.6)	18 Ga.	–	–	–	–	–	–	–	–
B72	1 3/32" (10.3)	1 3/16" (20.6)	18 Ga.	–	–	–	–	–	–	–	–

The selection has been prepared to provide a reference for available channel, materials and hole patterns. Material types available for various hole patterns are defined by numbers 1 thru 4. Some stainless steel channels with hole patterns are available on special order only.

*Metric equivalent for thicknesses shown in chart. ** 1 - Steel
 12 Ga. = 2.6 mm 18 Ga. = 1.2 mm 2 - Aluminum
 14 Ga. = 1.9 mm .105 = 2.6 mm 3 - Type 304 Stainless Steel
 16 Ga. = 1.5 mm .080 = 2.0 mm 4 - Type 316 Stainless Steel

Properties may vary due to commercial tolerances of the material.

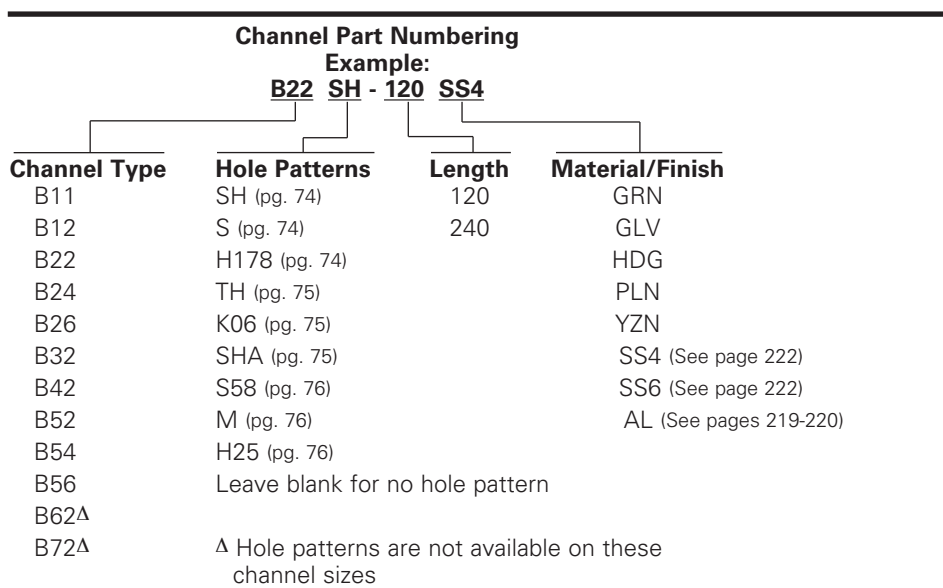

Reference page 48 for general fitting and standard finish specifications.

Channel Hole Patterns

B11SH thru B56SH SH Type Channel

• For beam loads use 90% of Channel Loading Chart

Part No.	Thickness	Height H		Weight	
		In.	mm	Lbs./Ft.	kg/m
B11SH	12 Ga. (2.6)	3 ¹ / ₄ "	(82.5)	2.97	(4.42)
B12SH	12 Ga. (2.6)	2 ⁷ / ₁₆ "	(61.9)	2.39	(3.55)
B22SH	12 Ga. (2.6)	1 ⁵ / ₈ "	(41.3)	1.82	(2.71)
B24SH	14 Ga. (1.9)	1 ⁵ / ₈ "	(41.3)	1.34	(1.99)
B26SH	16 Ga. (1.5)	1 ⁵ / ₈ "	(41.3)	1.07	(1.59)
B32SH	12 Ga. (2.6)	1 ³ / ₈ "	(34.9)	1.62	(2.41)
B42SH	12 Ga. (2.6)	1"	(25.4)	1.36	(2.02)
B52SH	12 Ga. (2.6)	1 ³ / ₁₆ "	(20.6)	1.19	(1.77)
B54SH	14 Ga. (1.9)	1 ³ / ₁₆ "	(20.6)	.91	(1.35)
B56SH	16 Ga. (1.5)	1 ³ / ₁₆ "	(20.6)	.80	(1.19)

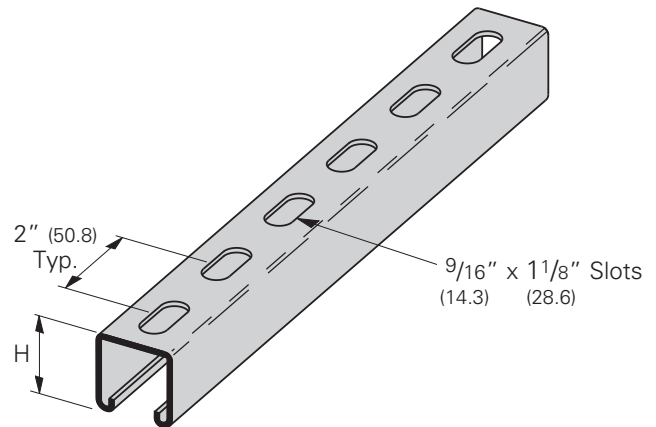

B11S thru B56S S Type Channel

• For beam loads use 90% of Channel Loading Chart

Part No.	Thickness	Height H		Weight	
		In.	mm	Lbs./Ft.	kg/m
B11S	12 Ga. (2.6)	3 ¹ / ₄ "	(82.5)	2.94	(4.37)
B12S	12 Ga. (2.6)	2 ⁷ / ₁₆ "	(61.9)	2.36	(3.51)
B22S	12 Ga. (2.6)	1 ⁵ / ₈ "	(41.3)	1.79	(2.66)
B24S	14 Ga. (1.9)	1 ⁵ / ₈ "	(41.3)	1.32	(1.96)
B26S	16 Ga. (1.5)	1 ⁵ / ₈ "	(41.3)	1.06	(1.58)
B32S	12 Ga. (2.6)	1 ³ / ₈ "	(34.9)	1.59	(2.36)
B42S	12 Ga. (2.6)	1"	(25.4)	1.33	(1.98)
B52S	12 Ga. (2.6)	1 ³ / ₁₆ "	(20.6)	1.16	(1.72)
B54S	14 Ga. (1.9)	1 ³ / ₁₆ "	(20.6)	.89	(1.32)
B56S	16 Ga. (1.5)	1 ³ / ₁₆ "	(20.6)	.79	(1.17)

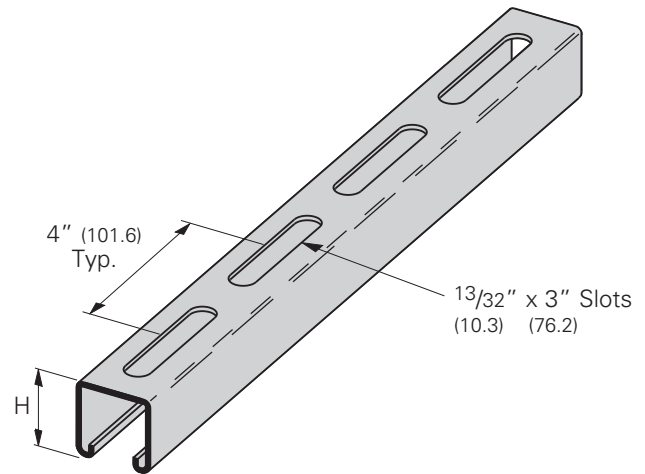

B11H17/8 thru B56H17/8 H17/8 Type Channel

• For beam loads use 90% of Channel Loading Chart

Part No.	Thickness	Height H		Weight	
		In.	mm	Lbs./Ft.	kg/m
B11H17/8	12 Ga. (2.6)	3 ¹ / ₄ "	(82.5)	3.00	(4.46)
B12H17/8	12 Ga. (2.6)	2 ⁷ / ₁₆ "	(61.9)	2.42	(3.60)
B22H17/8	12 Ga. (2.6)	1 ⁵ / ₈ "	(41.3)	1.85	(2.75)
B24H17/8	14 Ga. (1.9)	1 ⁵ / ₈ "	(41.3)	1.36	(2.02)
B26H17/8	16 Ga. (1.5)	1 ⁵ / ₈ "	(41.3)	1.09	(1.62)
B32H17/8	12 Ga. (2.6)	1 ³ / ₈ "	(34.9)	1.65	(2.45)
B42H17/8	12 Ga. (2.6)	1"	(25.4)	1.39	(2.07)
B52H17/8	12 Ga. (2.6)	1 ³ / ₁₆ "	(20.6)	1.22	(1.81)
B54H17/8	14 Ga. (1.9)	1 ³ / ₁₆ "	(20.6)	.93	(1.38)
B56H17/8	16 Ga. (1.5)	1 ³ / ₁₆ "	(20.6)	.82	(1.22)

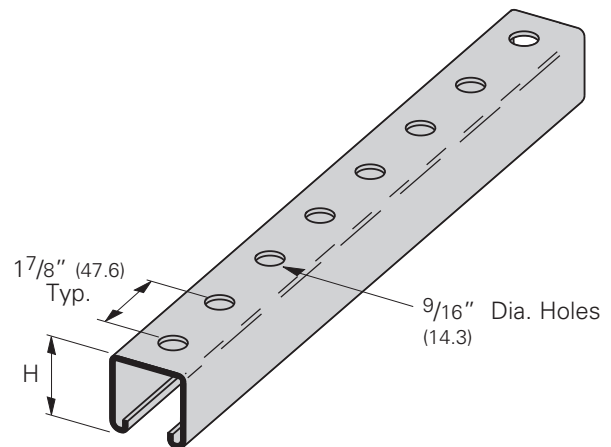

Reference page 48 for general fitting and standard finish specifications.