

# Metal framing channels

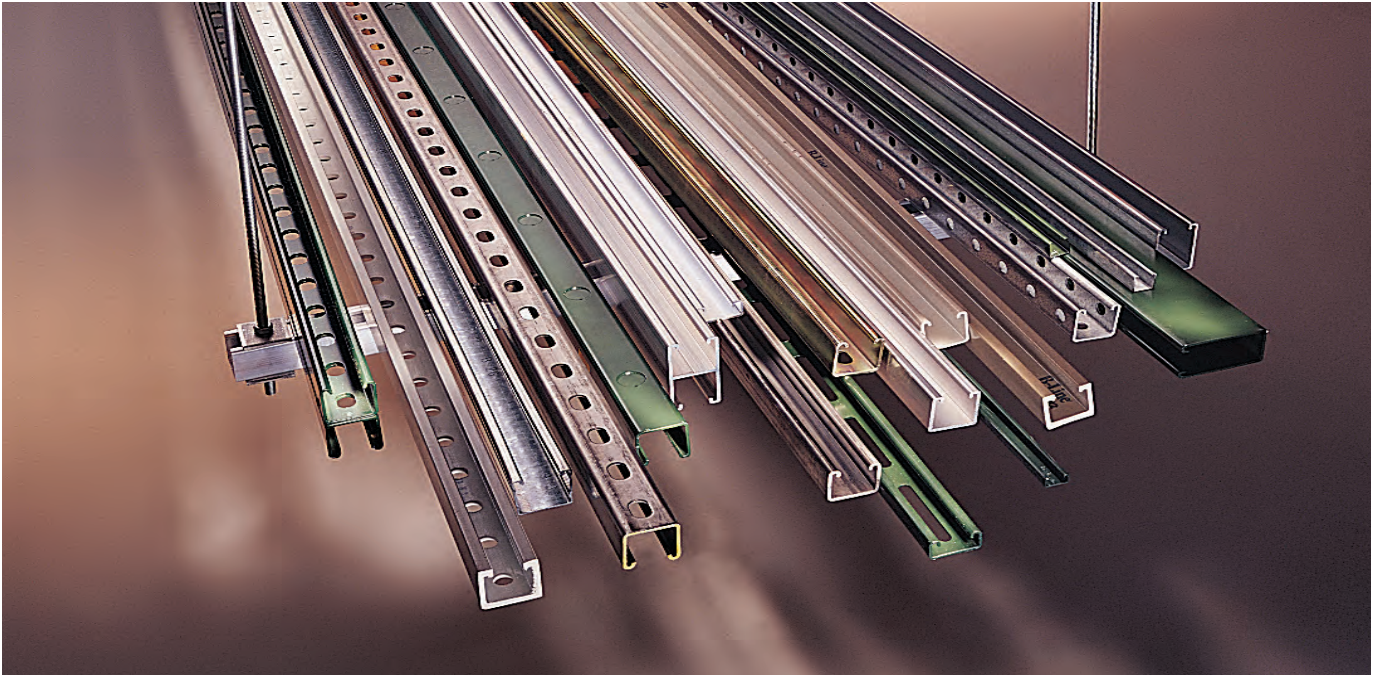

## Channel

Metal framing channel is cold formed on our modern rolling mills from 12 Ga. (2.6mm) and 14 Ga. (1.9mm) low carbon steel strips. A continuous slot with inturned lips provides the ability to make attachments at any point.

## Lengths & Tolerances

All channels excluding 'SH' style  $\pm 1/8"$  (3.2mm) on 10' (3.05m) and  $\pm 3/16"$  (4.76mm) on 20' (6.09m)  
 All 'SH' channels only  $\pm 1/4"$  (6.35mm) on 10' (3.05m) and  $\pm 1/2"$  (12.70mm) on 20' (6.09m)  
 Custom lengths are available upon request.

## Slots

Slotted series of channels offer full flexibility. A variety of pre-punched slot patterns eliminate the need for precise field measuring for hole locations. Slots offer wide adjustments in the alignment and bolt sizing.

## Holes

A variety of pre-punched  $9/16"$  (14.3 mm) diameter hole patterns are available in our channels. These hole patterns provide an economical alternative to costly field drilling required for many applications.

## Knockouts

When used with series B217-20 Closure Strips, knockout channels can be used to provide an economical U.L. listed surface raceway. Channels are furnished with  $7/8"$  (22.2 mm) knockouts on 6" (152 mm) centers, allowing for perfect fixture alignment on spans up to 20' (6.09 m).

## Materials & Finishes (Unless otherwise noted)

### Steel: Plain & Pre-galvanized

12 Ga. (2.6) and 14 Ga. (1.9)

Note: A minimum order may apply on special material and finishes.

## Design Load (Steel & Stainless Steel)

The design loads given for strut beam loads are based on a simple beam condition using an allowable stress of 25,000 psi. This allowable stress results in a safety factor of 1.68. This is based upon virgin steel minimum yield strength of 33,000 psi cold worked during rolling to an average yield stress of 42,000 psi. For aluminum channel loading multiply steel loading by a factor of 0.38.

| Finish Code | Finish                   | Specification                     |
|-------------|--------------------------|-----------------------------------|
| PLN         | Plain                    | ASTM A1011, 33,000 PSI min. yield |
| GRN         | DURA GREEN™              |                                   |
| GLV         | Pre-Galvanized           | ASTM A653 33,000 PSI min. yield   |
| HDG         | Hot-Dipped Galvanized    | ASTM A123                         |
| YZN         | Yellow Zinc Chromate     | ASTM B633 SC3 Type II             |
| SS4         | Stainless Steel Type 304 | ASTM A240                         |
| SS6         | Stainless Steel Type 316 | ASTM A240                         |
| AL          | Aluminum                 | Aluminum 6063-T6                  |







## Welding

Weld spacing is maintained between 2 1/2 inches (63.5 mm) and 4 inches (101.6 mm) on center. Through high quality control testing of welded channels and continuous monitoring of welding equipment, we provide the most consistent combination channels available today.

## Metric

Metric dimensions are shown in parentheses. Unless noted, all metric dimensions are in millimeters.

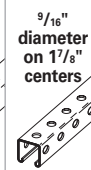
## Selection Chart for Channels, Materials and Hole Patterns

| Channel Type | Channel Dimensions  |  | Material & Thickness* |          |          |          | Channel Hole Pattern**   |   |   |   |   |
|--------------|---|--|-----------------------|----------|----------|----------|--|---|---|---|---|
|              | Height<br> | Width<br> | Stainless Steel       |          |          |          | SH   | S   | H1 <sup>7</sup> / <sub>8</sub>  | TH  | KO6   |
|              |   |  | Steel                 | Alum.    | Type 304 | Type 316 |  |  |  |  |  |
| <u>1</u>     | <u>2</u>  | <u>3</u>   | <u>4</u>              | <u>1</u> | <u>1</u> | <u>1</u> | <u>1</u>   | <u>1</u>  |   |   |   |
| <b>B11</b>   | 3 <sup>1</sup> / <sub>4</sub> " (82.5)  | 1 <sup>5</sup> / <sub>8</sub> " (41.3)   | 12 Ga.                | .105     | –        | –        | <u>1</u>   | <u>1</u>  | <u>1</u>  | –   | <u>1</u>  |
| <b>B12</b>   | 2 <sup>7</sup> / <sub>16</sub> " (61.9)   | 1 <sup>5</sup> / <sub>8</sub> " (41.3)   | 12 Ga.                | .105     | –        | –        | <u>1</u> <u>2</u>  | <u>1</u>  | <u>1</u> <u>2</u>   | –   | <u>1</u> <u>2</u>   |
| <b>B22</b>   | 1 <sup>5</sup> / <sub>8</sub> " (41.3)  | 1 <sup>5</sup> / <sub>8</sub> " (41.3)   | 12 Ga.                | .105     | 12 Ga.   | 12 Ga.   | <u>1</u> <u>2</u> <u>3</u> <u>4</u>  | <u>1</u> <u>3</u>   | <u>1</u> <u>2</u> <u>3</u> <u>4</u>   | <u>1</u>  | <u>1</u> <u>2</u>   |
| <b>B24</b>   | 1 <sup>5</sup> / <sub>8</sub> " (41.3)  | 1 <sup>5</sup> / <sub>8</sub> " (41.3)   | 14 Ga.                | –        | 14 Ga.   | 14 Ga.   | <u>1</u> <u>2</u> <u>3</u> <u>4</u>  | <u>1</u>  | <u>1</u> <u>2</u> <u>3</u> <u>4</u>   | –   | <u>1</u> <u>2</u>   |
| <b>B32</b>   | 1 <sup>3</sup> / <sub>8</sub> " (34.9)  | 1 <sup>5</sup> / <sub>8</sub> " (41.3)   | 12 Ga.                | –        | 12 Ga.   | –        | <u>1</u> <u>3</u>  | <u>1</u>  | <u>1</u> <u>3</u>   | –   | <u>1</u>  |
| <b>B42</b>   | 1" (25.4)   | 1 <sup>5</sup> / <sub>8</sub> " (41.3)   | 12 Ga.                | –        | 12 Ga.   | –        | <u>1</u> <u>3</u>  | <u>1</u>  | <u>1</u> <u>3</u>   | –   | <u>1</u>  |
| <b>B52</b>   | 1 <sup>3</sup> / <sub>16</sub> " (20.6)   | 1 <sup>5</sup> / <sub>8</sub> " (41.3)   | 12 Ga.                | –        | 12 Ga.   | 12 Ga.   | <u>1</u> <u>3</u> <u>4</u>   | <u>1</u>  | <u>1</u>  | –   | <u>1</u>  |
| <b>B54</b>   | 1 <sup>3</sup> / <sub>16</sub> " (20.6)   | 1 <sup>5</sup> / <sub>8</sub> " (41.3)   | 14 Ga.                | .080     | 14 Ga.   | 14 Ga.   | <u>1</u> <u>2</u> <u>3</u> <u>4</u>  | <u>1</u>  | <u>1</u> <u>2</u> <u>3</u> <u>4</u>   | –   | <u>1</u> <u>2</u>   |
| <b>B62</b>   | 1 <sup>3</sup> / <sub>16</sub> " (20.6)   | 1 <sup>3</sup> / <sub>16</sub> " (20.6)  | 18 Ga.                | –        | –        | –        | –  | –   | –   | –   | –   |
| <b>B72</b>   | 1 <sup>3</sup> / <sub>32</sub> " (10.3)   | 1 <sup>3</sup> / <sub>16</sub> " (20.6)  | 18 Ga.                | –        | –        | –        | –  | –   | –   | –   | –   |

The selection has been prepared to provide a reference for available channel, materials and hole patterns. Material types available for various hole patterns are defined by numbers 1 thru 4.

Some stainless steel channels with hole patterns are available on special order only.

\* Metric equivalent for thicknesses shown in chart.      \*\* 1 - Steel  
 12 Ga. = 2.6 mm                      18 Ga. = 1.2 mm                      2 - Aluminum  
 14 Ga. = 1.9 mm                      .105 = 2.6 mm                      3 - Type 304 Stainless Steel  
 16 Ga. = 1.5 mm                      .080 = 2.0 mm                      4 - Type 316 Stainless Steel

Properties may vary due to commercial tolerances of the material.

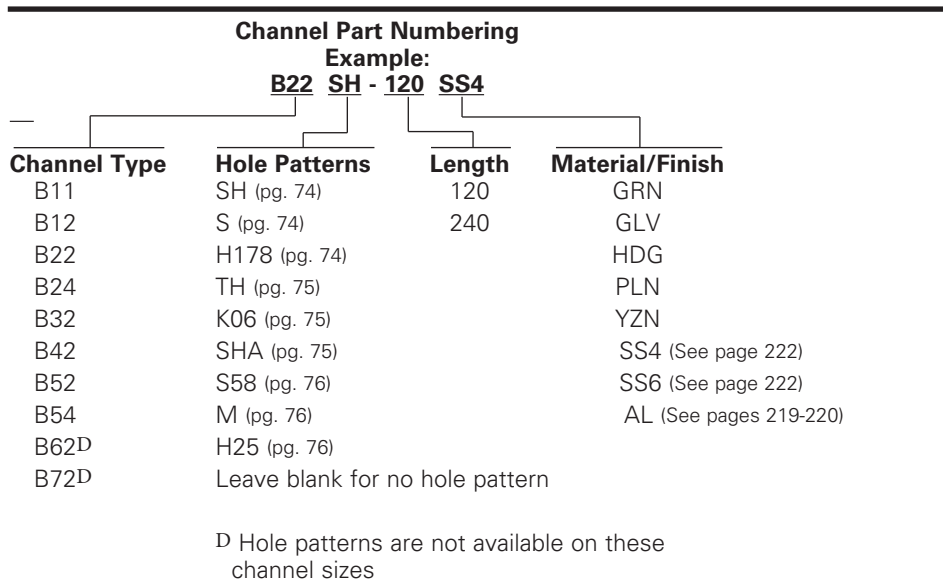

Reference page 48 for general fitting and standard finish specifications.

# Channel hole patterns

## B11SH thru B56SH SH Type Channel

- For beam loads use 90% of Channel Loading Chart

| Part No. | Thickness    | Height H                         |        | Weight   |        |
|----------|--------------|----------------------------------|--------|----------|--------|
|          |              | In.                              | mm     | Lbs./Ft. | kg/m   |
| B11SH    | 12 Ga. (2.6) | 3 <sup>1</sup> / <sub>4</sub> "  | (82.5) | 2.97     | (4.42) |
| B12SH    | 12 Ga. (2.6) | 2 <sup>7</sup> / <sub>16</sub> " | (61.9) | 2.39     | (3.55) |
| B22SH    | 12 Ga. (2.6) | 1 <sup>5</sup> / <sub>8</sub> "  | (41.3) | 1.82     | (2.71) |
| B24SH    | 14 Ga. (1.9) | 1 <sup>5</sup> / <sub>8</sub> "  | (41.3) | 1.34     | (1.99) |
| B32SH    | 12 Ga. (2.6) | 1 <sup>3</sup> / <sub>8</sub> "  | (34.9) | 1.62     | (2.41) |
| B42SH    | 12 Ga. (2.6) | 1"                               | (25.4) | 1.36     | (2.02) |
| B52SH    | 12 Ga. (2.6) | 1 <sup>3</sup> / <sub>16</sub> " | (20.6) | 1.19     | (1.77) |
| B54SH    | 14 Ga. (1.9) | 1 <sup>3</sup> / <sub>16</sub> " | (20.6) | .91      | (1.35) |

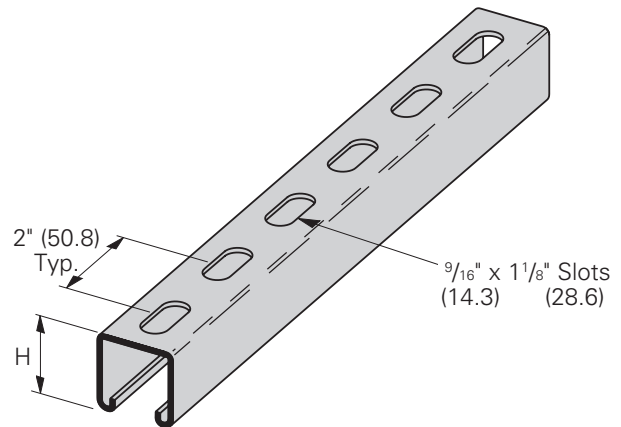

## B11S thru B56S S Type Channel

- For beam loads use 90% of Channel Loading Chart

| Part No. | Thickness    | Height H                         |        | Weight   |        |
|----------|--------------|----------------------------------|--------|----------|--------|
|          |              | In.                              | mm     | Lbs./Ft. | kg/m   |
| B11S     | 12 Ga. (2.6) | 3 <sup>1</sup> / <sub>4</sub> "  | (82.5) | 2.94     | (4.37) |
| B12S     | 12 Ga. (2.6) | 2 <sup>7</sup> / <sub>16</sub> " | (61.9) | 2.36     | (3.51) |
| B22S     | 12 Ga. (2.6) | 1 <sup>5</sup> / <sub>8</sub> "  | (41.3) | 1.79     | (2.66) |
| B24S     | 14 Ga. (1.9) | 1 <sup>5</sup> / <sub>8</sub> "  | (41.3) | 1.32     | (1.96) |
| B32S     | 12 Ga. (2.6) | 1 <sup>3</sup> / <sub>8</sub> "  | (34.9) | 1.59     | (2.36) |
| B42S     | 12 Ga. (2.6) | 1"                               | (25.4) | 1.33     | (1.98) |
| B52S     | 12 Ga. (2.6) | 1 <sup>3</sup> / <sub>16</sub> " | (20.6) | 1.16     | (1.72) |
| B54S     | 14 Ga. (1.9) | 1 <sup>3</sup> / <sub>16</sub> " | (20.6) | .89      | (1.32) |

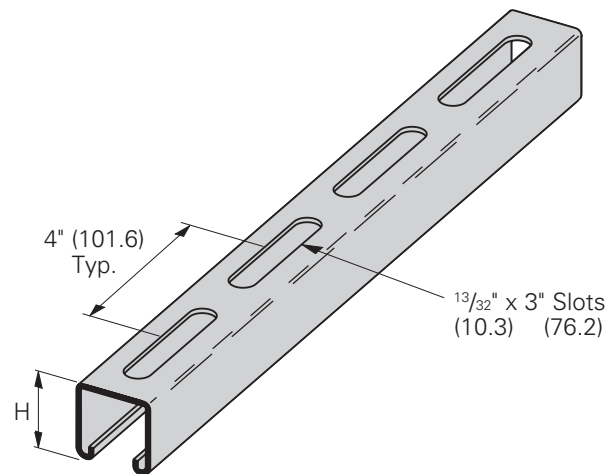

## B11H17/8 thru B56H17/8 H17/8 Type Channel

- For beam loads use 90% of Channel Loading Chart

| Part No. | Thickness    | Height H                         |        | Weight   |        |
|----------|--------------|----------------------------------|--------|----------|--------|
|          |              | In.                              | mm     | Lbs./Ft. | kg/m   |
| B11H17/8 | 12 Ga. (2.6) | 3 <sup>1</sup> / <sub>4</sub> "  | (82.5) | 3.00     | (4.46) |
| B12H17/8 | 12 Ga. (2.6) | 2 <sup>7</sup> / <sub>16</sub> " | (61.9) | 2.42     | (3.60) |
| B22H17/8 | 12 Ga. (2.6) | 1 <sup>5</sup> / <sub>8</sub> "  | (41.3) | 1.85     | (2.75) |
| B24H17/8 | 14 Ga. (1.9) | 1 <sup>5</sup> / <sub>8</sub> "  | (41.3) | 1.36     | (2.02) |
| B32H17/8 | 12 Ga. (2.6) | 1 <sup>3</sup> / <sub>8</sub> "  | (34.9) | 1.65     | (2.45) |
| B42H17/8 | 12 Ga. (2.6) | 1"                               | (25.4) | 1.39     | (2.07) |
| B52H17/8 | 12 Ga. (2.6) | 1 <sup>3</sup> / <sub>16</sub> " | (20.6) | 1.22     | (1.81) |
| B54H17/8 | 14 Ga. (1.9) | 1 <sup>3</sup> / <sub>16</sub> " | (20.6) | .93      | (1.38) |

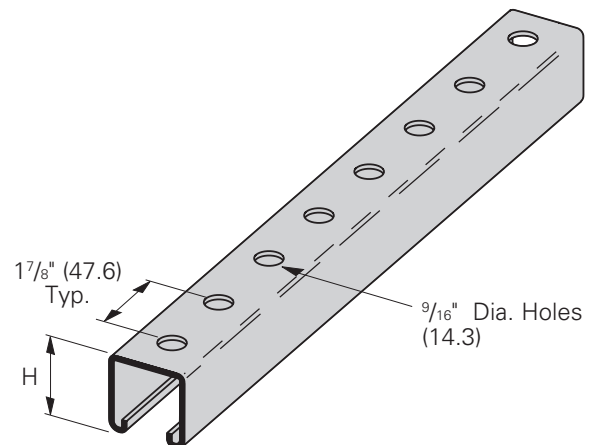

Reference page 48 for general fitting and standard finish specifications.