



Customer information packet

VEM3661T-5

3HP, 1755RPM, 3PH, 60HZ, 182TC, 0632M, TEFC, F1

Class - None

Division - Not Applicable

Specifications

Enclosure	TEFC
Frame	182TC
Frame Material	Iron
Frequency	60.00 Hz
Haz Area Class and Group	None
Haz Area Division	Not Applicable
Motor Letter Type	Three Phase
Output @ Frequency	3.000 HP @ 60 HZ
Phase	3
Synchronous Speed @ Frequency	1800 RPM @ 60 HZ
Voltage @ Frequency	575.0 V @ 60 HZ
Agency Approvals	CURUSEEV NEMA PREMIUM NEMA_PREMIUM UR CSA EEV
Ambient Temperature	40 °C
Auxillary Box	No Auxillary Box
Auxillary Box Lead Termination	None
Base Indicator	No Mounting
Bearing Grease Type	Polyrex EM (-20F +300F)
Blower	None
Current @ Voltage	3.300 A @ 575.0 V
Design Code	B
Drip Cover	No Drip Cover
Duty Rating	CONT
Efficiency @ 100% Load	89.5 %
Electrically Isolated Bearing	Not Electrically Isolated
Feedback Device	NO FEEDBACK
Front Face Code	Standard
Front Shaft Indicator	None
Heater Indicator	No Heater

Part detail

Revision	N
Type	AC
Mech. spec.	06H016
Base	
Status	PRD/A
Elec. spec.	06WGX319
Layout	06LYH016
Eff. date	01-29-2025
CD Diagram	CD0006
Poles	04
Leads	3#16
Proprietary	False
Created date	10-10-2011

High Voltage Full Load Amps	3.3 a
Insulation Class	F
Inverter Code	Inverter Ready
KVA Code	J
Lifting Lugs	Standard Lifting Lugs
Locked Bearing Indicator	Locked Bearing
Motor Lead Exit	Ko Box
Motor Lead Quantity/Wire Size	3 @ 16 AWG
Motor Lead Termination	Flying Leads
Motor Standards	NEMA
Motor Type	0632M
Mounting Arrangement	F1
Number of Poles	4
Overall Length	15.98 IN
Power Factor	77
Product Family	General Purpose
Pulley End Bearing Type	Ball
Pulley Face Code	C-Face
Pulley Shaft Indicator	Standard
Rodent Screen	None
Service Factor	1.15
Shaft Diameter	1.125 IN
Shaft Extension Location	Pulley End
Shaft Ground Indicator	No Shaft Grounding
Shaft Rotation	Reversible
Shaft Slinger Indicator	No Slinger
Speed	1755 rpm
Speed Code	Single Speed
Starting Method	Direct on line
Thermal Device - Bearing	None
Thermal Device - Winding	None
Vibration Sensor Indicator	No Vibration Sensor
Winding Thermal 1	None
Winding Thermal 2	None

Nameplate

NP3441L									
CAT.NO.	VEM3661T-5								
SPEC.	06H016X319G1								
HP	3								
VOLTS	575								
AMP	3.3								
RPM	1755								
FRAME	182TC		HZ	60		PH	3		
SER.F.	1.15	CODE	J	DES	B	CL	F		
NEMA-NOM-EFF	89.5	PF	77						
RATING	40C AMB-CONT								
CC	010A								
DE	6206		ODE	6205					
ENCL	TEFC	SN							
VPWM INVERTER READY									
CT6-60H(10:1)VT3-60H(20:1									
	SFA 3.5								

AC Induction Motor Performance Data

Record # 75292

Typical performance - not guaranteed values

Winding: 06WGX319-R001		Type: 0632M		Enclosure: TEFC	
Nameplate Data			460 V, 60 Hz: Single Voltage Motor		
Rated Output (HP)		3	Full Load Torque		9.17 LB-FT
Volts		575	Start Configuration		direct on line
Full Load Amps		3.3	Breakdown Torque		20.9 LB-FT
R.P.M.		1755	Pull-up Torque		11.4 LB-FT
Hz	60 Phase	3	Locked-rotor Torque		12.71 LB-FT
NEMA Design Code	B KVA Code	J	Starting Current		18.81 A
Service Factor (S.F.)		1.15	No-load Current		1.29 A
NEMA Nom. Eff.	89.5 Power Factor	77	Line-line Res. @ 25°C		6.2 Ω
Rating - Duty	40C AMB-CONT		Temp. Rise @ Rated Load		41°C
S.F. Amps			Temp. Rise @ S.F. Load		54°C
			Locked-rotor Power Factor		41.1
			Rotor inertia		0.298 LB-FT ²

Load Characteristics 460 V, 60 Hz, 3 HP

% of Rated Load	25	50	75	100	125	150	S.F.
Power Factor	54	74	81	84	85	84	85
Efficiency	86.9	89.6	89.6	88.1	86.2	83.1	87
Speed	1785	1769	1753	1734	1711	1684	1720
Line amperes	1.57	2.17	2.94	3.81	4.83	6.1	4.42

ABB Motors and Mechanical Inc.

WINDING # 06WGX319

3 HP 3 PH 60 HZ 1755 RPM 460 V 0632M

Typical performance - not guaranteed values.

TORQUES (LB-FT): PO=20.9 PU=11.4 LR=12.71 LRA=18.81

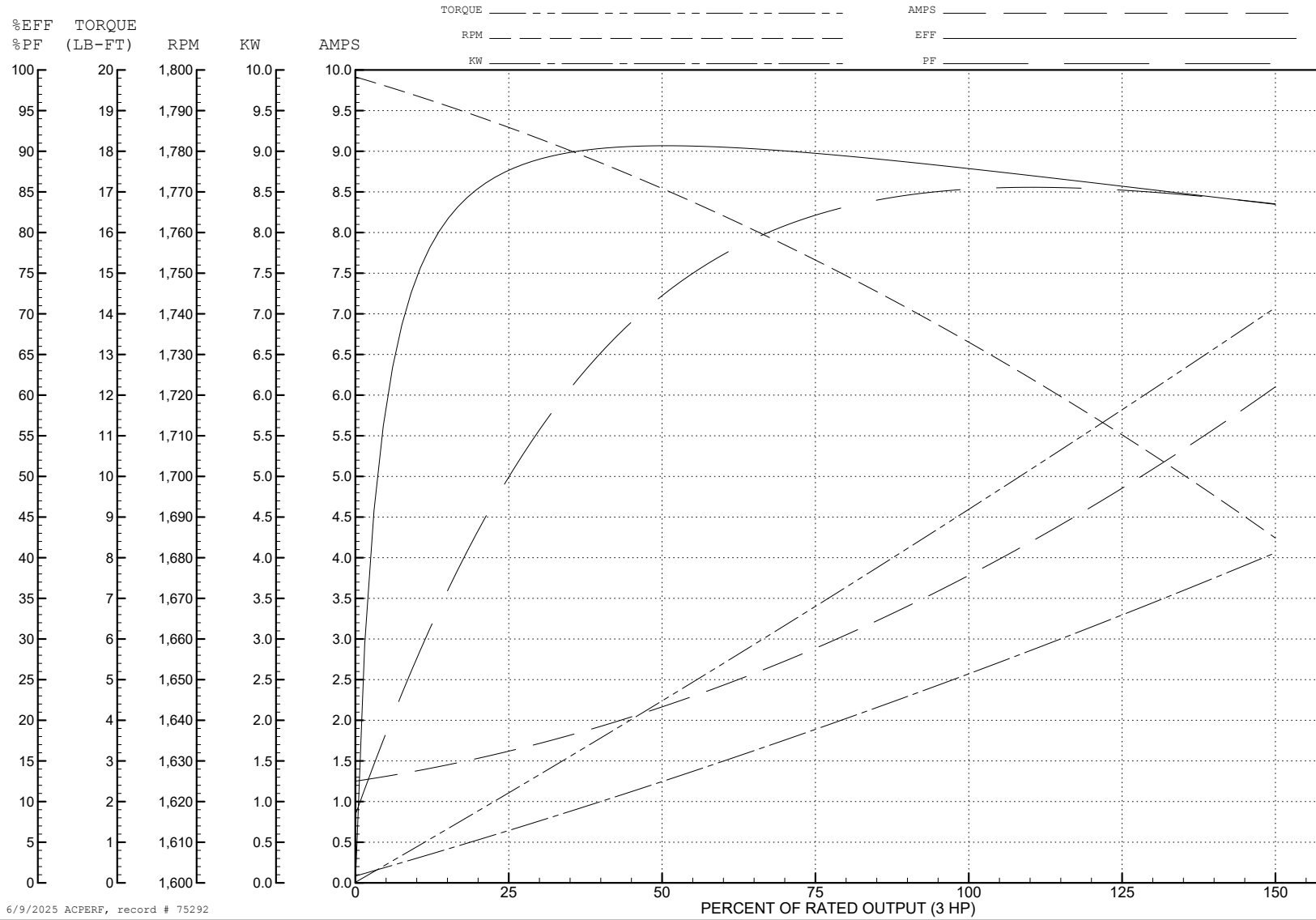

6/9/2025 ACPERF, record # 75292

AC Induction Motor Performance Data

Record # 84796

Typical performance - not guaranteed values

Winding: 06WGX319-R001		Type: 0632M		Enclosure: TEFC	
Nameplate Data			575 V, 60 Hz: Single Voltage Motor		
Rated Output (KW)	2.2	Full Load Torque	12.21 N-M		
Volts	575	Start Configuration	direct on line		
Full Load Amps	3.3	Breakdown Torque	28.35 N-M		
R.P.M.	1755	Pull-up Torque	15.46 N-M		
Hz	60	Locked-rotor Torque	17.23 N-M		
NEMA Design Code	B	Starting Current	18.81 A		
Service Factor (S.F.)	1.15	No-load Current	1.29 A		
NEMA Nom. Eff.	89.5	Line-line Res. @ 25°C	6.2 Ω		
Rating - Duty	40C	Temp. Rise @ Rated Load	40°C		
S.F. Amps	AMB-CONT	Temp. Rise @ S.F. Load	48°C		
		Locked-rotor Power Factor	41.5		
		Rotor inertia	0.0126 kg-m ²		

Load Characteristics 575 V, 60 Hz, 2.2 KW

% of Rated Load	25	50	75	100	125	150	S.F.
Power Factor	43	59	65	67	68	67	68
Efficiency	86.7	89.8	89.5	88.1	86.3	83.1	87
Speed	1785	1769	1753	1735	1713	1685	1722
Line amperes	1.56	2.16	2.91	3.76	4.75	6	4.35

ABB Motors and Mechanical Inc.

WINDING # 06WX319

Typical performance - not guaranteed values.

2.2 KW 3 PH 60 HZ 1755 RPM 575 V 0632M

TORQUES (N-M) : PO=28.35 PU=15.46 LR=17.23 LRA=18.81

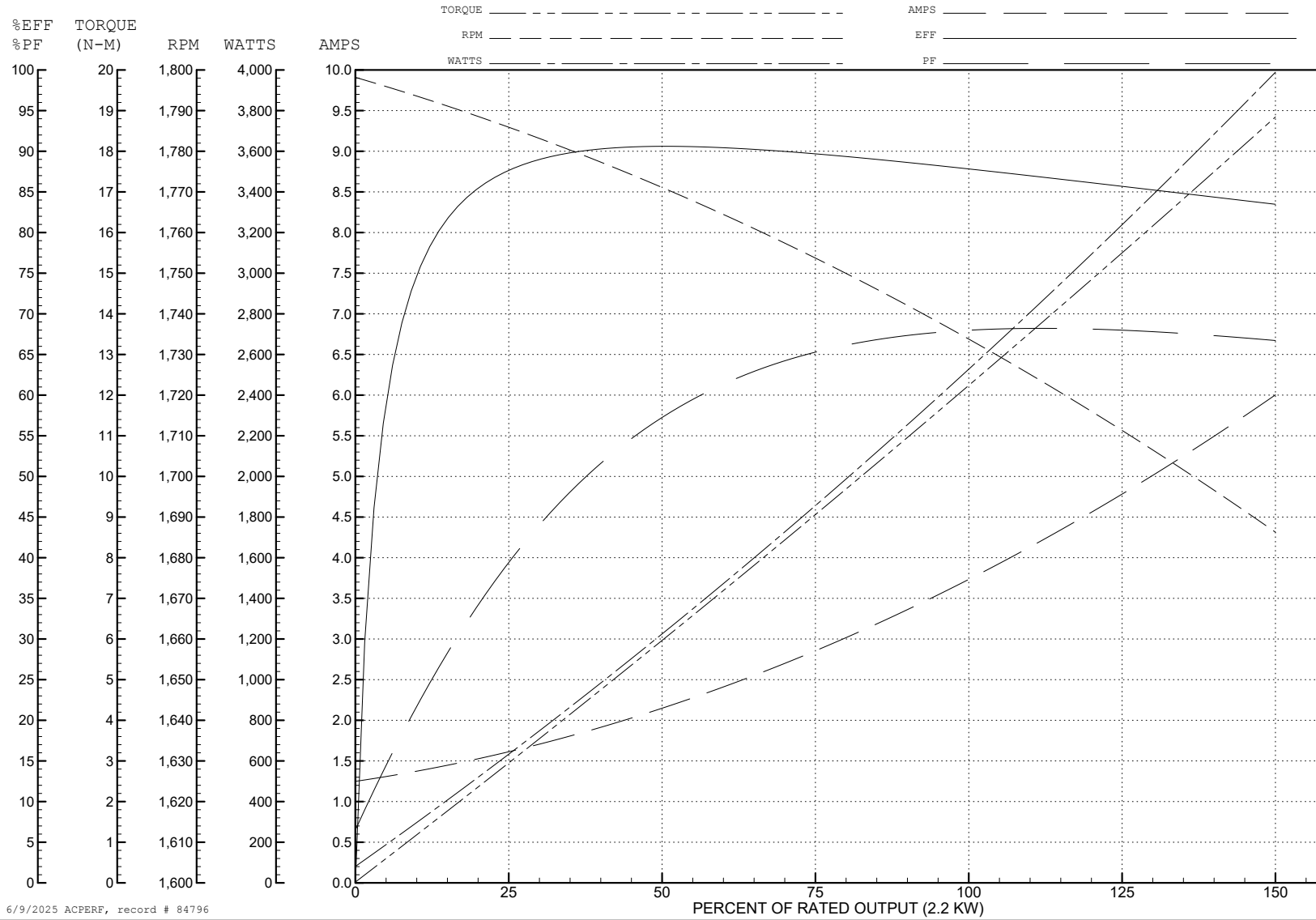

6/9/2025 ACPERF, record # 84796

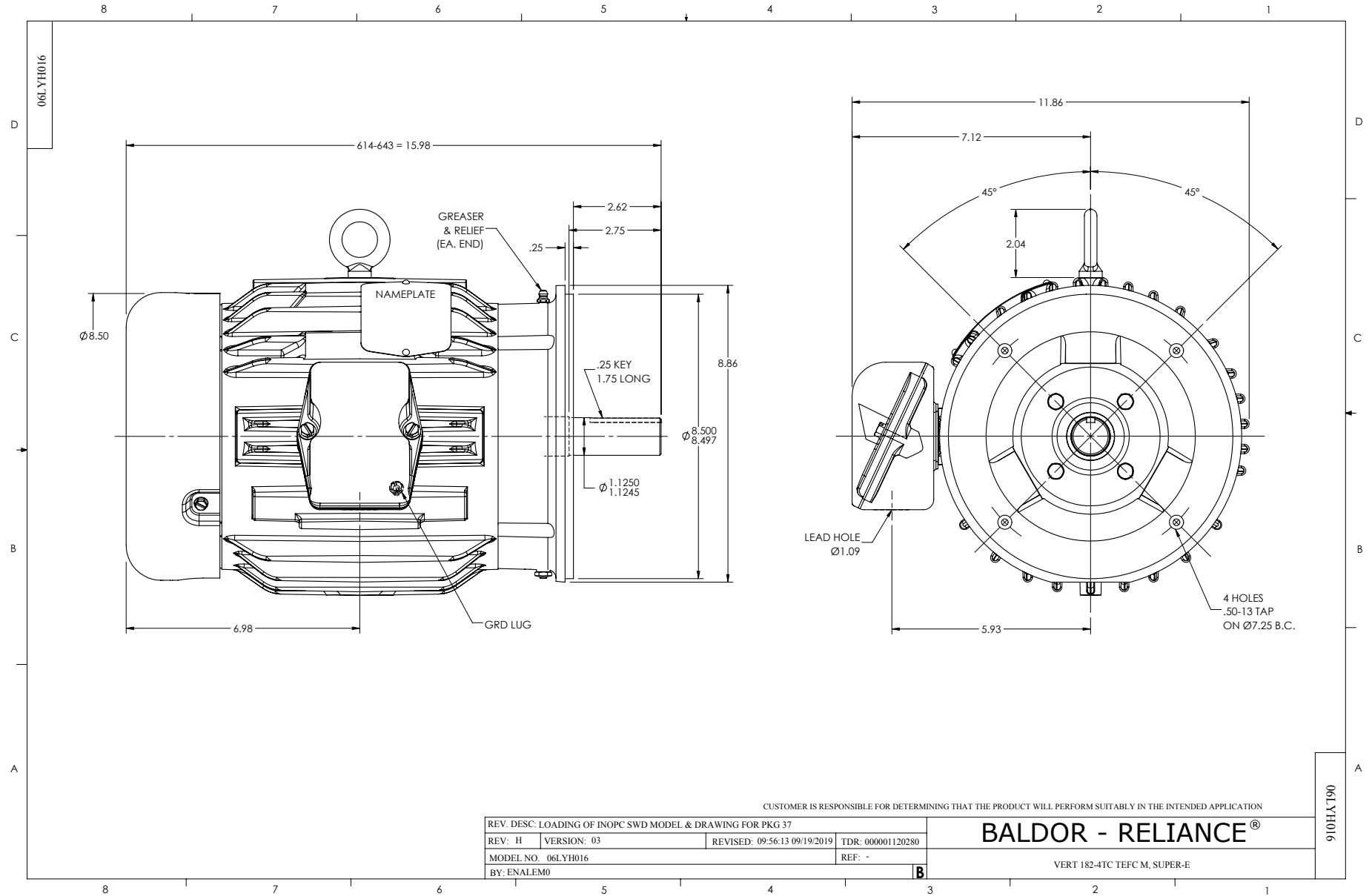

CUSTOMER IS RESPONSIBLE FOR DETERMINING THAT THE PRODUCT WILL PERFORM SUITABLY IN THE INTENDED APPLICATION

REV. DESC: LOADING OF INOPC SWD MODEL & DRAWING FOR PKG 37			
REV: H	VERSION: 03	REVISED: 09:56:13 09/19/2019	TDR: 000001120280
MODEL NO. 06LYH016		REF: -	
BY: ENALEM0			

BALDOR - RELIANCE®

VERT 182-4TC TEFC M, SUPER-E

910HX190

CD0006

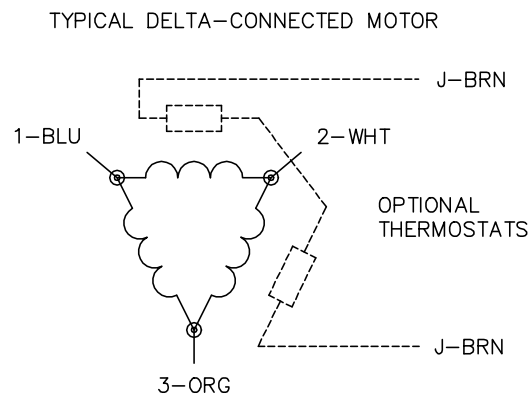
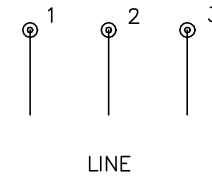
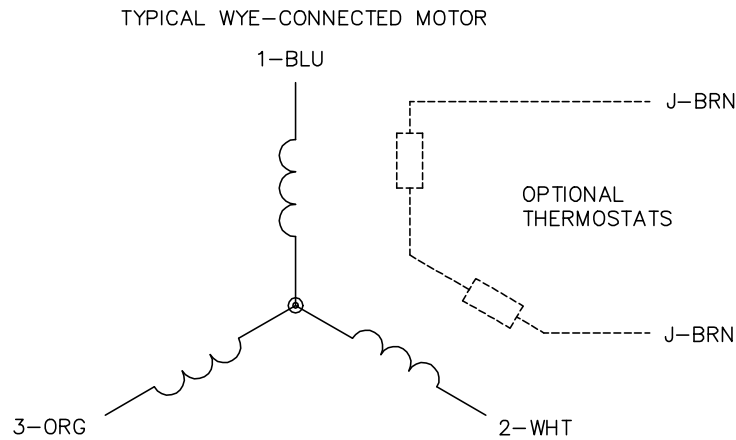

NOTES:

1. THREE LEAD MOTOR MAY BE EITHER WYE CONNECTED OR DELTA CONNECTED.
2. INTERCHANGE ANY TWO LINE LEADS TO REVERSE ROTATION.
3. OPTIONAL THERMOSTATS ARE PROVIDED WHEN SPECIFIED.
4. ACTUAL NUMBER OF INTERNAL PARALLEL CIRCUITS MAY VARY.
5. LEAD COLORS ARE OPTIONAL. LEADS MUST BE NUMBERED AS SHOWN.

CD0006

REV. DESC: ADD CLASS CONN00000007		
REV. LTR: E	VERSION: 01	TDR: 000001099922
FILE: \AAA\00005\141	REVISED: 10:24:49 02/19/2019	BY: ENBRIRO
MTL: -	© □	

BALDOR - RELIANCE®

3PH, SV, 3 LEADS, WYE OR DELTA CONNECTED

SH 1 of 1