

BALDOR • RELIANCE

Customer information packet

VEM3546-5

1HP, 1774RPM, 3PH, 60HZ, 56C, 3522M, TEFC, F1, N

Class - None

Division - Not Applicable

Specifications

Enclosure	TEFC
Frame	56C
Frame Material	Steel
Frequency	60.00 Hz
Haz Area Class and Group	None
Haz Area Division	Not Applicable
Motor Letter Type	Three Phase
Output @ Frequency	1.000 HP @ 60 HZ
Phase	3
Synchronous Speed @ Frequency	1800 RPM @ 60 HZ
Voltage @ Frequency	575.0 V @ 60 HZ
Agency Approvals	CSA EEV NEMA PREMIUM NEMA_PREMIUM UR
Ambient Temperature	40 °C
Auxillary Box	No Auxillary Box
Auxillary Box Lead Termination	None
Base Indicator	No Mounting
Bearing Grease Type	Polyrex EM (-20F +300F)
Blower	None
Current @ Voltage	1.300 A @ 575.0 V
Design Code	B
Drip Cover	No Drip Cover
Duty Rating	CONT
Efficiency @ 100% Load	85.5 %
Electrically Isolated Bearing	Not Electrically Isolated
Feedback Device	NO FEEDBACK
Front Shaft Indicator	None
Heater Indicator	No Heater
High Voltage Full Load Amps	1.3 a
Insulation Class	F

Part detail

Revision	G
Type	AC
Mech. spec.	35A013
Base	
Status	PRD/A
Elec. spec.	35WGG119
Layout	35LYA013
Eff. date	04-29-2024
CD Diagram	CD0006
Poles	04
Leads	3#18
Proprietary	False
Created date	10-01-2021

Inverter Code	Inverter Ready
KVA Code	M
Lifting Lugs	No Lifting Lugs
Locked Bearing Indicator	Locked Bearing
Motor Lead Quantity/Wire Size	3 @ 18 AWG
Motor Lead Termination	Flying Leads
Motor Standards	NEMA
Motor Type	3522M
Mounting Arrangement	F1
Number of Poles	4
Overall Length	13.22 IN
Power Factor	70
Product Family	General Purpose
Pulley End Bearing Type	Ball
Pulley Face Code	C-Face
Pulley Shaft Indicator	Standard
Rodent Screen	None
RoHS Status	ROHS COMPLIANT
Service Factor	1.15
Shaft Diameter	0.625 IN
Shaft Ground Indicator	No Shaft Grounding
Shaft Rotation	Reversible
Shaft Slinger Indicator	No Slinger
Speed	1775 rpm
Speed Code	Single Speed
Starting Method	Direct on line
Thermal Device - Bearing	None
Thermal Device - Winding	None
Vibration Sensor Indicator	No Vibration Sensor
Winding Thermal 1	None
Winding Thermal 2	None

Nameplate

NP3441L									
CAT.NO.	VEM3546-5								
SPEC.	35A013G119G1								
HP	1								
VOLTS	575								
AMP	1.3								
RPM	1775								
FRAME	56C		HZ	60		PH	3		
SER.F.	1.15	CODE	M	DES	B	CL	F		
NEMA-NOM-EFF	85.5	PF	70						
RATING	40C AMB-CONT								
CC	010A								
DE	6205		ODE	6203					
ENCL	TEFC	SN							
VPWM INVERTER READY									
CT6-60H(10:1)VT3-60H(20:1									
	SFA 1.4								

AC Induction Motor Performance Data

Record # 99012

Typical performance - not guaranteed values

Winding: 35WGG119-R001		Type: 3522M		Enclosure: TEFC	
Nameplate Data			575 V, 60 Hz: Single Voltage Motor		
Rated Output (HP)		1	Full Load Torque		2.99 LB-FT
Volts		575	Start Configuration		direct on line
Full Load Amps		1.3	Breakdown Torque		13.4 LB-FT
R.P.M.		1775	Pull-up Torque		6.8 LB-FT
Hz	60 Phase	3	Locked-rotor Torque		8.3 LB-FT
NEMA Design Code	B KVA Code	M	Starting Current		10.9 A
Service Factor (S.F.)		1.15	No-load Current		0.87 A
NEMA Nom. Eff.	85.5 Power Factor	70	Line-line Res. @ 25°C		30.1 Ω
Rating - Duty	40C AMB-CONT		Temp. Rise @ Rated Load		36°C
S.F. Amps		1.4	Temp. Rise @ S.F. Load		42°C
			Locked-rotor Power Factor		63.4
			Rotor inertia		0.159 lb-ft ²

Load Characteristics 575 V, 60 Hz, 1 HP

% of Rated Load	25	50	75	100	125	150	S.F.
Power Factor	31	48	61	70	76	80	74
Efficiency	72.1	81.6	84.9	85.8	85.7	85	85.7
Speed	1794	1787	1781	1774	1767	1758	1770
Line amperes	0.89	0.97	1.1	1.26	1.44	1.65	1.37

ABB Motors and Mechanical Inc.

WINDING # 35WGG119

Typical performance - not guaranteed values.

1 HP 3 PH 60 HZ 1775 RPM 575 V 3522M

TORQUES (LB-FT): PO=13.4 PU=6.8 LR=8.3 LRA=10.9

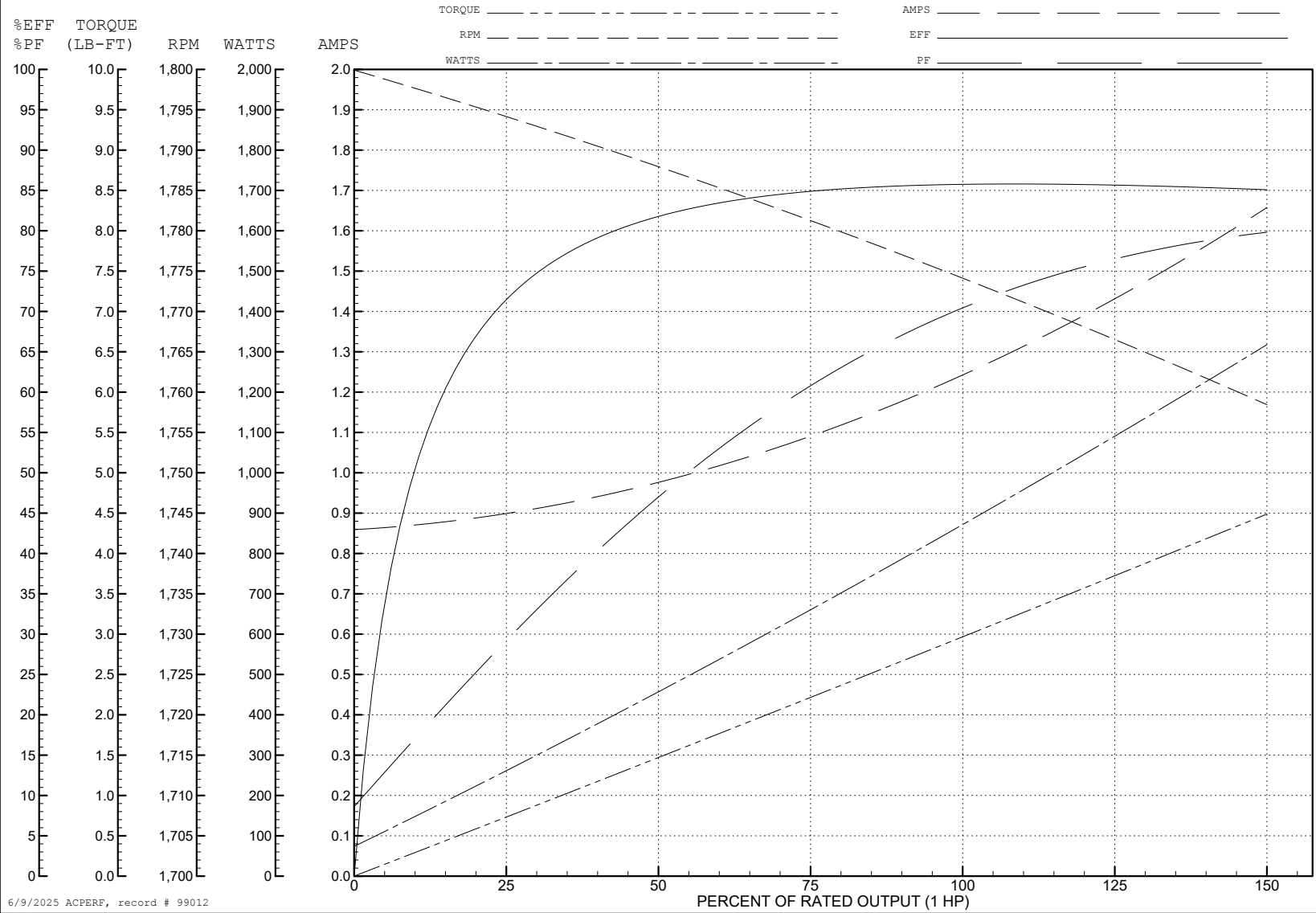

6/9/2025 ACPERF, record # 99012

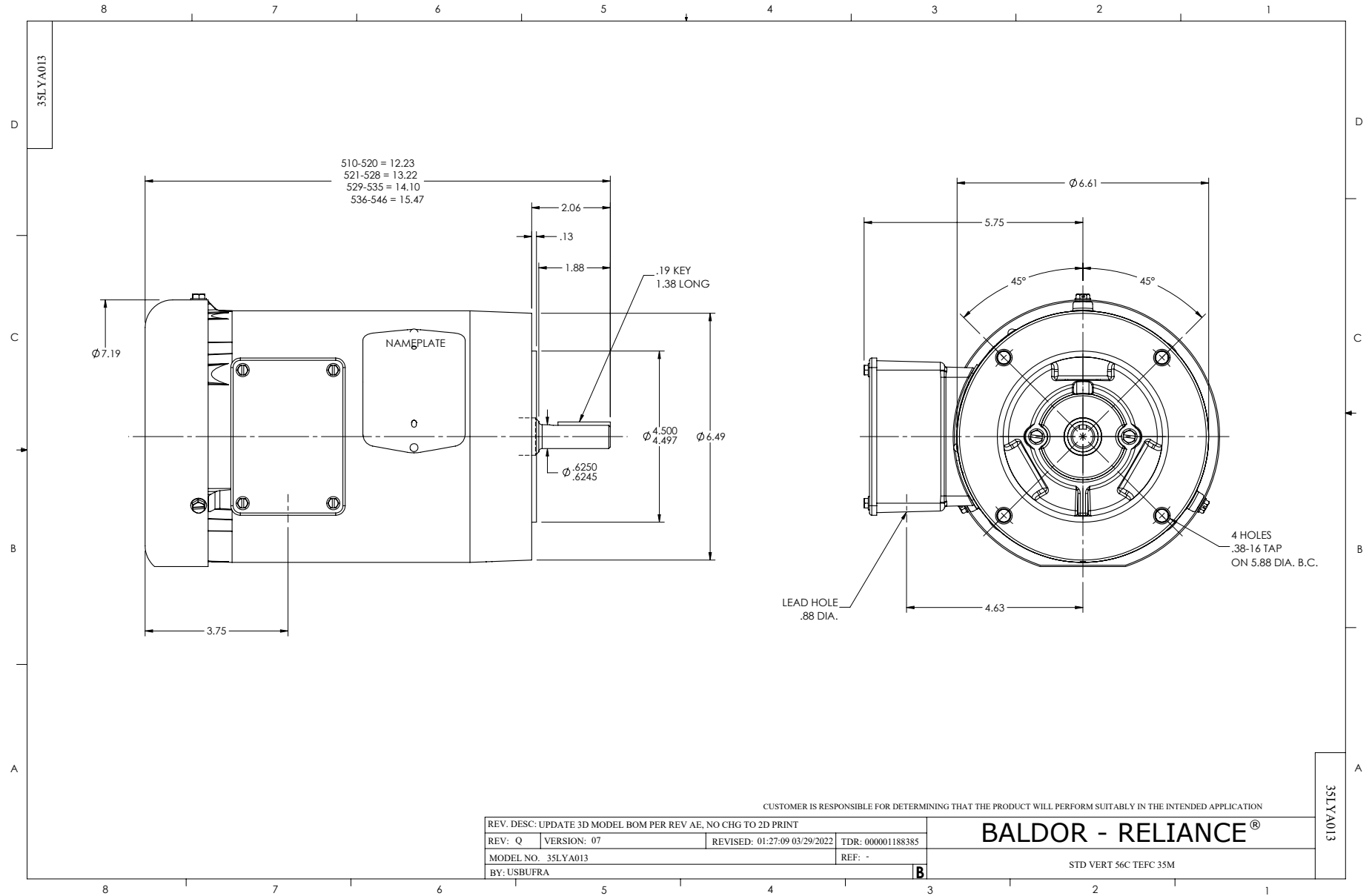

CD0006

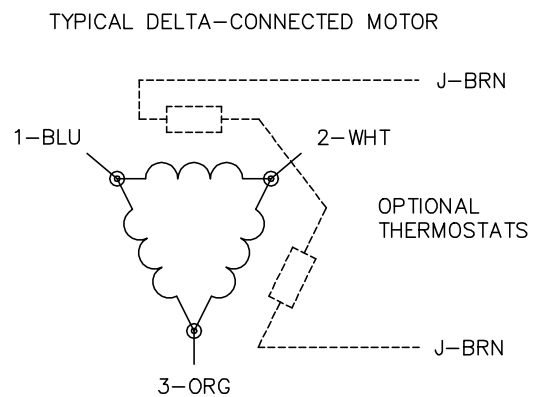
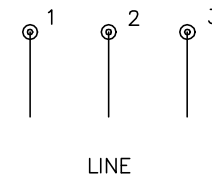
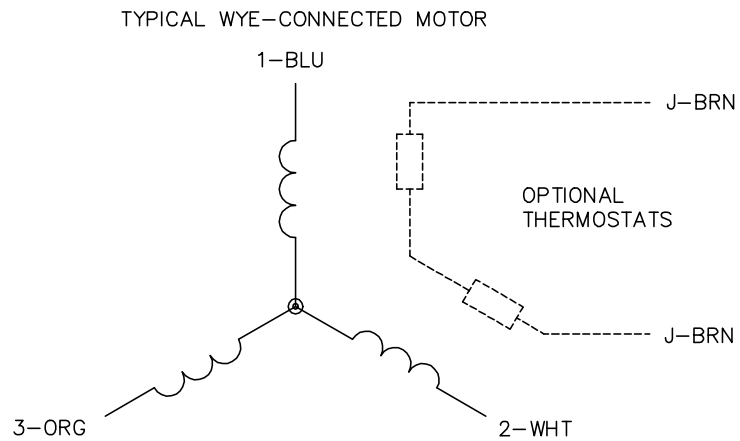

NOTES:

1. THREE LEAD MOTOR MAY BE EITHER WYE CONNECTED OR DELTA CONNECTED.
2. INTERCHANGE ANY TWO LINE LEADS TO REVERSE ROTATION.
3. OPTIONAL THERMOSTATS ARE PROVIDED WHEN SPECIFIED.
4. ACTUAL NUMBER OF INTERNAL PARALLEL CIRCUITS MAY VARY.
5. LEAD COLORS ARE OPTIONAL. LEADS MUST BE NUMBERED AS SHOWN.

CD0006

REV. DESC: ADD CLASS CONN00000007		
REV. LTR: E	VERSION: 01	TDR: 000001099922
FILE: \AAA\00005\141	REVISED: 10:24:49 02/19/2019	BY: ENBRIRO
MTL: -	© □	

BALDOR - RELIANCE®

3PH, SV, 3 LEADS, WYE OR DELTA CONNECTED

SH 1 of 1