

BALDOR • RELIANCE

Customer information packet

VEM2334T-5

20HP, 1770RPM, 3PH, 60HZ, 256TC, 0960M, TEFC, F

Class - None

Division - Not Applicable

Copyright © All product information within this document is subject to ABB Motors and Mechanical Inc. copyright © protection, unless otherwise noted.

6/9/2025 4:13:06 AM

Specifications

Enclosure	TEFC
Frame	256TC
Frame Material	Iron
Frequency	60.00 Hz
Haz Area Class and Group	None
Haz Area Division	Not Applicable
Motor Letter Type	Three Phase
Output @ Frequency	20.000 HP @ 60 HZ
Phase	3
Synchronous Speed @ Frequency	1800 RPM @ 60 HZ
Voltage @ Frequency	575.0 V @ 60 HZ
Agency Approvals	CSA EEV NEMA PREMIUM NEMA_PREMIUM UR
Ambient Temperature	40 °C
Auxillary Box	No Auxillary Box
Auxillary Box Lead Termination	None
Base Indicator	No Mounting
Bearing Grease Type	Polyrex EM (-20F +300F)
Blower	None
Current @ Voltage	19.200 A @ 575.0 V
Design Code	A
Drip Cover	No Drip Cover
Duty Rating	CONT
Efficiency @ 100% Load	93.0 %
Electrically Isolated Bearing	Not Electrically Isolated
Feedback Device	NO FEEDBACK
Front Face Code	Standard
Front Shaft Indicator	None
Heater Indicator	No Heater
High Voltage Full Load Amps	19.2 a

Part detail

Revision	T
Type	AC
Mech. spec.	09C103
Base	
Status	PRD/A
Elec. spec.	09WGT507
Layout	09LYC103
Eff. date	05-14-2024
CD Diagram	CD0006
Poles	04
Leads	3#10
Proprietary	False
Created date	11-17-2017

Insulation Class	F
Inverter Code	Inverter Ready
KVA Code	J
Lifting Lugs	Standard Lifting Lugs
Locked Bearing Indicator	Locked Bearing
Motor Lead Exit	Ko Box
Motor Lead Quantity/Wire Size	3 @ 10 AWG
Motor Lead Termination	Flying Leads
Motor Standards	NEMA
Motor Type	0960M
Mounting Arrangement	F1
Number of Poles	4
Overall Length	23.86 IN
Power Factor	83
Product Family	General Purpose
Pulley End Bearing Type	Ball
Pulley Face Code	C-Face
Pulley Shaft Indicator	Standard
Rodent Screen	None
Service Factor	1.15
Shaft Diameter	1.625 IN
Shaft Extension Location	Pulley End
Shaft Ground Indicator	No Shaft Grounding
Shaft Rotation	Reversible
Shaft Slinger Indicator	Shaft Slinger
Speed	1770 rpm
Speed Code	Single Speed
Starting Method	Direct on line
Thermal Device - Bearing	None
Thermal Device - Winding	None
Vibration Sensor Indicator	No Vibration Sensor
Winding Thermal 1	None
Winding Thermal 2	None

Nameplate

NP3441L									
CAT.NO.	VEM2334T-5								
SPEC.	09C103T507G1								
HP	20								
VOLTS	575								
AMP	19.2								
RPM	1770								
FRAME	256TC		HZ	60		PH	3		
SER.F.	1.15	CODE	J	DES	A	CL	F		
NEMA-NOM-EFF	93	PF	83						
RATING	40C AMB-CONT								
CC	010A								
DE	6309		ODE	6208					
ENCL	TEFC	SN							
VPWM INVERTER READY									
CT6-60H(10:1)VT3-60H(20:1									
	SFA 21.7								

AC Induction Motor Performance Data

Record # 67979

Typical performance - not guaranteed values

Winding: 09WGT507-R001		Type: 0960M	Enclosure: TEFC		
Nameplate Data			575 V, 60 Hz: Single Voltage Motor		
Rated Output (HP)	20	Full Load Torque	59.29 LB-FT		
Volts	575	Start Configuration	direct on line		
Full Load Amps	19.2	Breakdown Torque	231 LB-FT		
R.P.M.	1770	Pull-up Torque	126 LB-FT		
Hz	60	Phase	3	Locked-rotor Torque	140 LB-FT
NEMA Design Code	A	KVA Code	J	Starting Current	158 A
Service Factor (S.F.)	1.15	No-load Current	8.28 A		
NEMA Nom. Eff.	93	Power Factor	83	Line-line Res. @ 25°C	0.499 Ω
Rating - Duty	40C AMB-CONT		Temp. Rise @ Rated Load	58°C	
S.F. Amps			Temp. Rise @ S.F. Load	69°C	
			Locked-rotor Power Factor	26.5	
			Rotor inertia	2.65 lb-ft ²	

Load Characteristics 575 V, 60 Hz, 20 HP

% of Rated Load	25	50	75	100	125	150	S.F.
Power Factor	45	67	78	83	86	87	85
Efficiency	89.2	93	93.7	93.5	93.1	92.4	93.3
Speed	1793	1786	1779	1772	1764	1755	1767
Line amperes	9.41	11.99	15.34	19.19	23.44	27.92	21.7

ABB Motors and Mechanical Inc.

WINDING # 09WGT507

Typical performance - not guaranteed values.

20 HP 3 PH 60 HZ 1770 RPM 575 V 0960M

TORQUES (LB-FT): PO=231 PU=126 LR=140 LRA=158

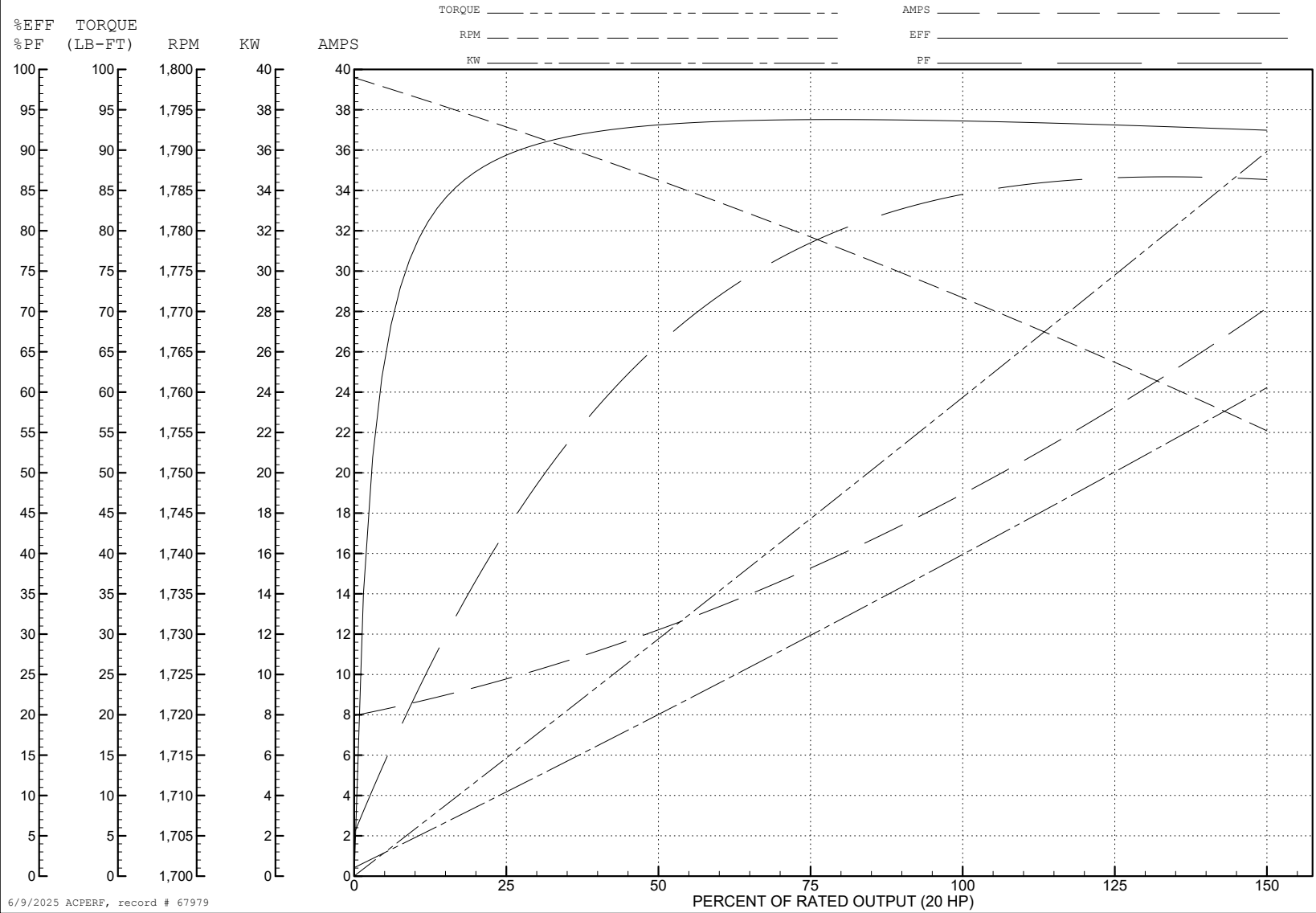

6/9/2025 ACPERF, record # 67979

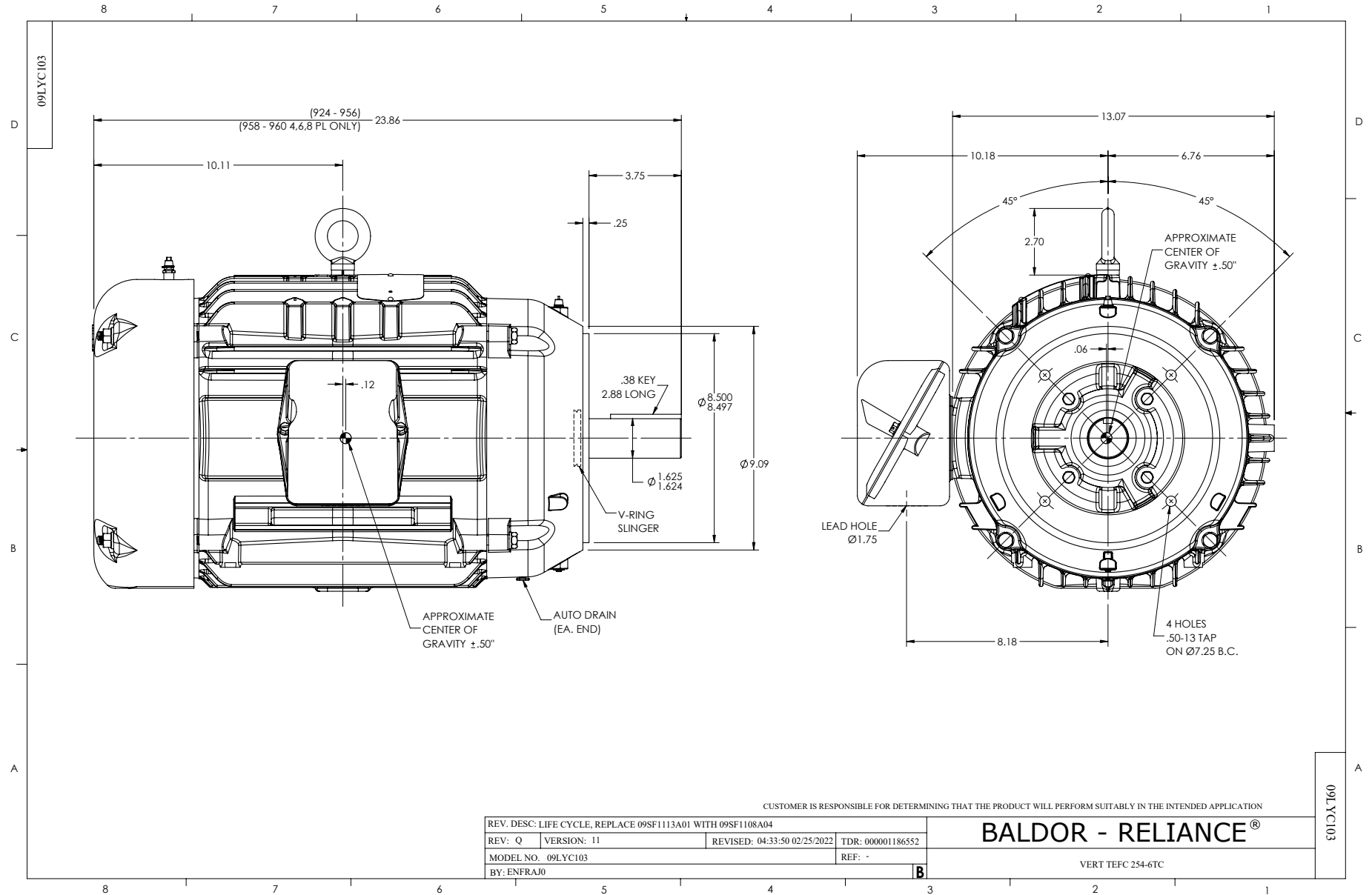

CD0006



NOTES:

1. THREE LEAD MOTOR MAY BE EITHER WYE CONNECTED OR DELTA CONNECTED.
2. INTERCHANGE ANY TWO LINE LEADS TO REVERSE ROTATION.
3. OPTIONAL THERMOSTATS ARE PROVIDED WHEN SPECIFIED.
4. ACTUAL NUMBER OF INTERNAL PARALLEL CIRCUITS MAY VARY.
5. LEAD COLORS ARE OPTIONAL. LEADS MUST BE NUMBERED AS SHOWN.

CD0006

REV. DESC: ADD CLASS CONN00000007		
REV. LTR: E	VERSION: 01	TDR: 000001099922
FILE: \AAA\00005\141	REVISED: 10:24:49 02/19/2019	BY: ENBRIRO
MTL: -	© □	

BALDOR - RELIANCE®

3PH, SV, 3 LEADS, WYE OR DELTA CONNECTED

SH 1 of 1