



Customer information packet

EM25404T-4

400HP, 1780RPM, 3PH, 60HZ, 449T, DP, F1

Class - None

Division - Not Applicable

Specifications

Enclosure	DP
Frame	449T
Frame Material	Iron
Frequency	60.00 Hz
Haz Area Class and Group	None
Haz Area Division	Not Applicable
Motor Letter Type	Three Phase
Output @ Frequency	400.000 HP @ 60 HZ
Phase	3
Synchronous Speed @ Frequency	1800 RPM @ 60 HZ
Voltage @ Frequency	460.0 V @ 60 HZ
Agency Approvals	CCSAUSEEV
Ambient Temperature	40 °C
Auxillary Box	No Auxillary Box
Base Indicator	Rigid
Bearing Grease Type	Polyrex EM (-20F +300F)
Current @ Voltage	437.000 A @ 460.0 V
Design Code	B
Drip Cover	No Drip Cover
Duty Rating	CONT
Efficiency @ 100% Load	96.2 %
Feedback Device	NO FEEDBACK
Heater Indicator	No Heater
High Voltage Full Load Amps	437.0 a
Insulation Class	F
Inverter Code	Inverter Ready
IP Rating	NONE
KVA Code	F
Lifting Lugs	Standard Lifting Lugs
Motor Lead Quantity/Wire Size	12 @ 1 AWG
Motor Standards	NEMA
Motor Type	A44140M

Part detail

Revision	A
Type	AC
Mech. spec.	
Base	
Status	PRD/A
Elec. spec.	A44WG3164
Layout	604989-505
Eff. date	03-01-2017
CD Diagram	416820-008
Poles	04
Leads	6#1 (02 per group)
Proprietary	False
Created date	11-24-2015

Mounting Arrangement	F1
Number of Poles	4
Overall Length	48.12 IN
Power Factor	89
Product Family	General Industrial
Pulley End Bearing Type	Ball
Pulley Face Code	Standard
Service Factor	1.15
Shaft Diameter	3.375 IN
Shaft Ground Indicator	No Shaft Grounding
Shaft Rotation	Reversible
Shaft Slinger Indicator	No Slinger
Speed	1780 rpm
Speed Code	Single Speed
Starting Method	Wye Start - Delta Run
Thermal Device - Bearing	None
Thermal Device - Winding	None

Nameplate

NP2496L	
MOBIL POLYREX EM	

NP2349L

SPEC NO.	A44-8061-3164	CAT.NO.	EM25404T-4	FRAME	449T
HP	400	VOLTS	460	PHASE	3
RPM	1780	AMPS	437	HZ	60
DRIVE END BEARING	90BC03J30X	DUTY	CONT	INSUL.CLASS	F
OPP D.E. BEARING	90BC03J30X	ENCL	DP	CODE	F
SER.NO.		POWER FACTOR	89	NEMA-NOM-EFFICIENCY	96.2
				MAX CORR KVAR	57
				GUARANTEED EFFICIENCY	95.4
				NEMA NOM/CSA QUOTED EFF	
				MOTOR WEIGHT	2799

604989-505

DUTY MASTER ALTERNATING CURRENT MOTORS
SQUIRREL-CAGE INDUCTION

ENCLOSURE: PROTECTED; OPEN DRIP PROOF

FRAME E449T

COOLING: SELF-VENTILATED

MOUNTING: FOOT, F-1 SIDE

14X14X12 FABRICATED STEEL C/BOX

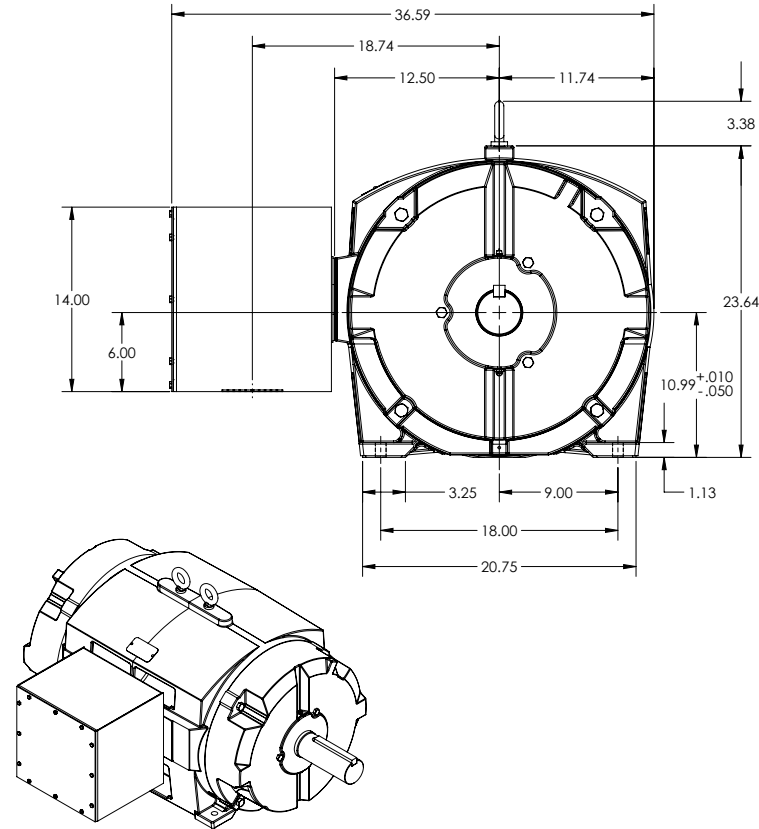
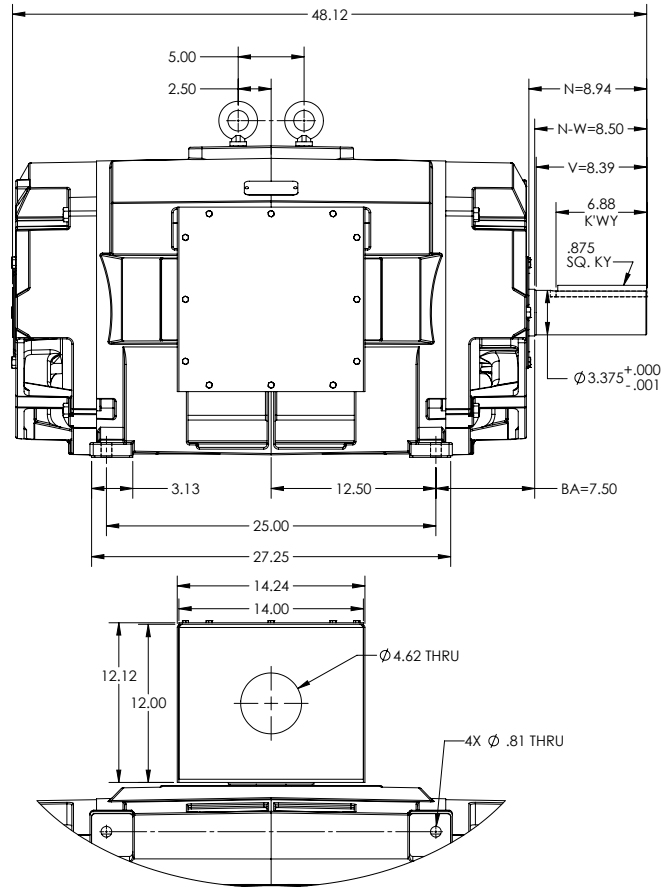

IF MOUNTING CLEARANCE DETAILS ARE REQUIRED, CONSULT FACTORY.

MAXIMUM PERMISSIBLE SHAFT RUNOUT WHEN MEASURED AT END OF STANDARD SHAFT EXTENSION IS .003" T.I.R.

MOTOR WEIGHT: 2100 LBS
*MAY VARY BY 15% DEPENDING ON RATING

DIMENSIONS ARE IN INCHES

CUSTOMER IS RESPONSIBLE FOR DETERMINING THAT MOTOR PERFORMANCE IS SUITABLE IN THE APPLICATION.

SHEET NUMBER
1 OF 1

S05-686F09

REV. DESC: UPDATE MODEL TO ADD EXTERNAL HARDWARE PER PROD MGM			
REV: B	VERSION: 02	REVISED: 07-28-84 07/14/2022	TDR: 000001193529
MODEL NO. 604989-505			
BY: USBUFA			

BALDOR

449T PROT F-1 FT - 14X14X12 FAB STL C/BOX

S05-686F09

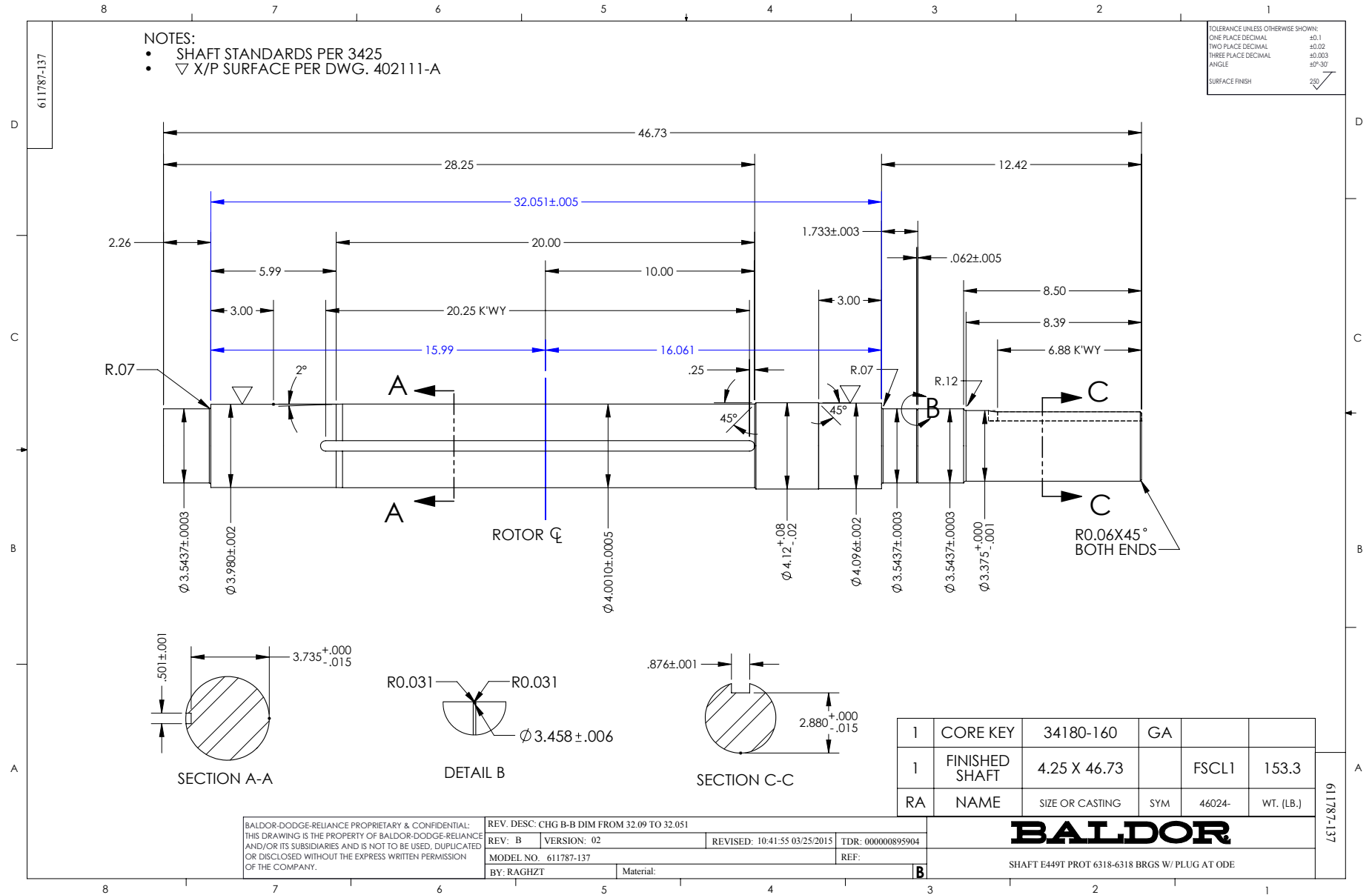

416820-008

A-C MOTOR CONNECTION DIAGRAM

STANDARD 6 LEAD

Y START – DELTA RUN

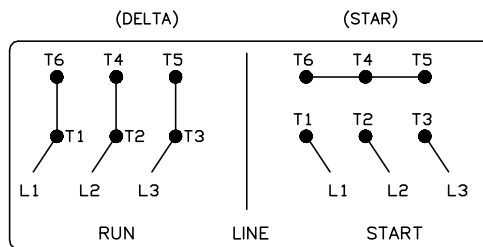
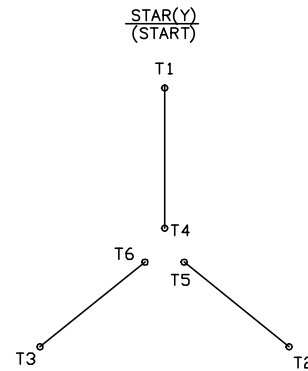
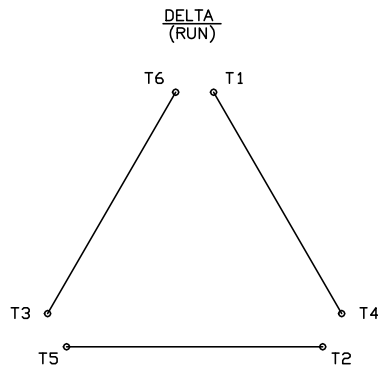

< N. P. 1767-DC >

REV. DESC: ADDED T4 TO Y CONNECT DIAGRAM		
REV. LTR: D	VERSION: 04	TDR: 00000847713
FILE: \RAG\00001\808	REVISED: 10: 41: 26 04/08/2014	BY: RAGJSS1
MTL: -	© □	

BALDOR

CONNECT DIAGRAM STD 6 LEAD Y START DELTA RUN

SH 1 of 1

416820-008