

pro^{sense}® SLT Series Submersible Level Transmitters

Part No. [SLT1-005-L30](#)Part No. [SLT2-005-L30](#)

Submersible Level Transmitters

The ProSense SLT series submersible level sensors provide continuous liquid level measurement by sensing the hydrostatic pressure produced by the height of liquid above the sensor and providing a 4-20 mA output signal compatible with PLCs, panel meters, data loggers, and other electronic equipment. The shielded cable with atmospheric vent tube and a tough polyurethane jacket incorporating an exclusive "water block" liner beneath the jacket is attached to the sensor using an over-molding process that prevents moisture intrusion. The SLT1 series has a slim 1-inch diameter housing and a ported bullet nose cap for protection of the sensor diaphragm. The SLT2 series features a large 2.75 inch diameter PTFE flexible diaphragm surrounded by a 316 stainless steel non-fouling protective cage. Accessories include a desiccant vent filter, aneroid bellows, junction boxes, and replacement nose caps.

Features

- Models with ported nose cap or non-fouling cage for diaphragm protection
- Durable 316 SS construction for reliable, long life in harsh environments
- Shielded cable with atmospheric vent; over-molded to prevent moisture intrusion
- 1/2 inch NPT male threaded conduit connection on the sensor housing standard
- Pre-calibrated ranges up to 50 psig (115.3 ftWC)
- to meet the most common submersible level applications in vented tanks, reservoirs & ground water systems
- +/-0.25% accuracy standard
- All sensors include UL and FM hazardous location approvals for intrinsically safe applications and are CE marked
- Made in the USA

Applications

- Lift station monitoring
- Liquid level in vented tank
- Landfill leachate monitoring
- Construction by-pass pumping
- Dewatering
- Pump control
- Slurry tank liquid level
- Wastewater



SLT Series Submersible Level Transmitters					
Model	Range	Cable Length*	Diaphragm / Protection	Price	Weight (lbs)
SLT1-005-L30	0–5 psig (11.5 ftWC)	30ft (9.1 m)	316 Stainless steel diaphragm / Ported POM (polyoxymethylene) nose cap		1.9
SLT1-010-L40	0–10 psig (23.1 ftWC)	40ft (12.2 m)			2.4
SLT1-015-L60	0–15 psig (34.6 ftWC)	60ft (18.3 m)			3.4
SLT1-020-L60	0–20 psig (46.1 ftWC)	60ft (18.3 m)			3.4
SLT1-030-L100	0–30 psig (69.2 ftWC)	100ft (30.5 m)			5.4
SLT1-050-L140	0–50 psig (115.3 ftWC)	140ft (42.7 m)			7.4
SLT2-005-L30	0–5 psig (11.5 ftWC)	30ft (9.1 m)	Flexible PTFE (polytetrafluoroethylene) diaphragm / Non-fouling stainless steel cage		5.0
SLT2-010-L40	0–10 psig (23.1 ftWC)	40ft (12.2 m)			5.5
SLT2-015-L60	0–15 psig (34.6 ftWC)	60ft (18.3 m)			6.5
SLT2-020-L60	0–20 psig (46.1 ftWC)	60ft (18.3 m)			6.5
SLT2-030-L100	0–30 psig (69.2 ftWC)	100ft (30.5 m)			8.5

* It is required that any excess cable length be accommodated in a service loop and that the cable NOT be shortened as this will void the warranty. If longer transmitter cable is needed, terminate the sensor in an [SLT-JB1](#) or [SLT-JB2](#) junction box and run standard non-vented instrumentation cable between the junction box and the measuring electronics.

prosense® SLT Series Submersible Level Transmitters

SLT Series Submersible Level Transmitter Technical Specifications	
Static Accuracy*	±0.25% FS (full scale)
Resolution	+0.0001% FS
Wetted Materials	SLT1: 316SS; POM (polyoxymethylene), PUR (polyurethane); SLT2: 316SS; POM (polyoxymethylene), PUR (polyurethane), PTFE (polytetrafluoroethylene)
Compensated Temp. Range	0 to 50°C [32 to 122°F]
Thermal Error	±0.1% FS/°C (maximum allowable deviation from the best fit straight line due to a change in temperature)
Operating Temp. Range	-20 to 60°C [-4 to 140°F]
Protection Rating	IP 68, NEMA 6P
Excitation	9–28 VDC
Input Current	20mA max
Output	4–20 mA
Zero Offset	w0.25 mA
Output Impedance	750Ω max. @ 24VDC (see loop resistance chart by the wiring drawings for other power supply voltages)
Mounting	Vertical
Insulation Resistance	100MΩ at 50VDC
Circuit Protection	Polarity, surge/shorted output
Cable Jacket Material	PUR (polyurethane)
Cable Pull Strength	200lbs (90kg)
Number of Conductors	2 + Drain
Conductor Size	22AWG (0.33 mm ²) spiral tinned copper wire foil shield with 20AWG (0.52 mm ²) drain wire
Vent Tube	PUR (polyethylene) 0.016 in (0.41 mm) ID
Cable Seal	Molded PUR (polyurethane)
Certifications / Agency Approvals	UL (E197886), CE, RoHS, FM (3036412)

* Combined effects of non-linearity, hysteresis and repeatability, best fit straight line method.

Dimensions

inches [mm]

SLT1 Series

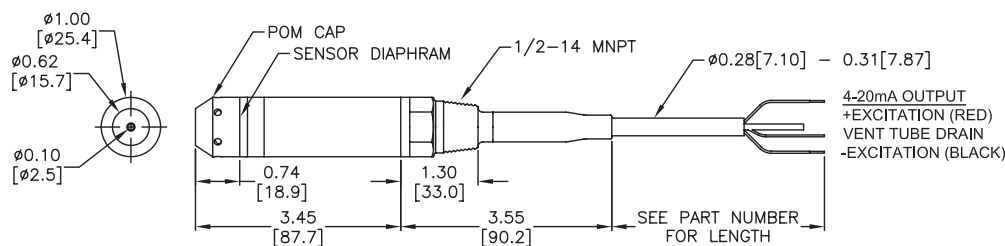

See our website www.AutomationDirect.com for complete Engineering drawings.

prosense® SLT Series Submersible Level Transmitters

Dimensions inches [mm]

SLT2 Series

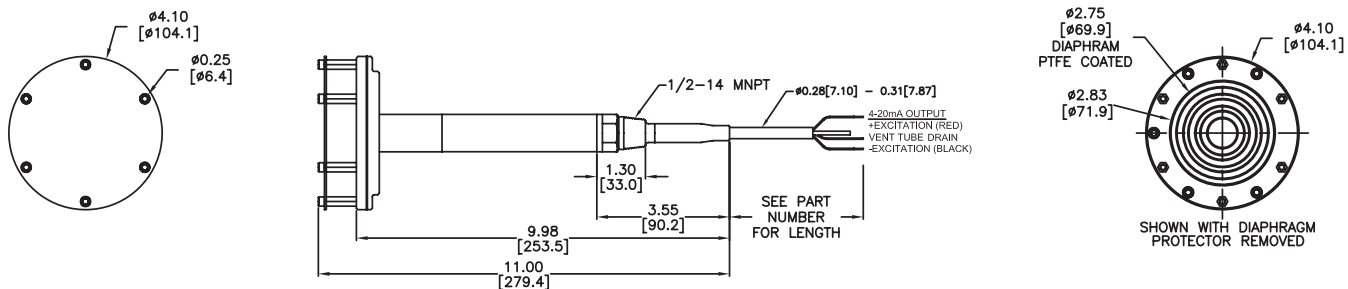

See our website www.AutomationDirect.com for complete Engineering drawings.

Wiring

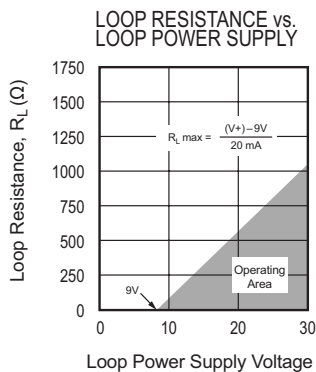
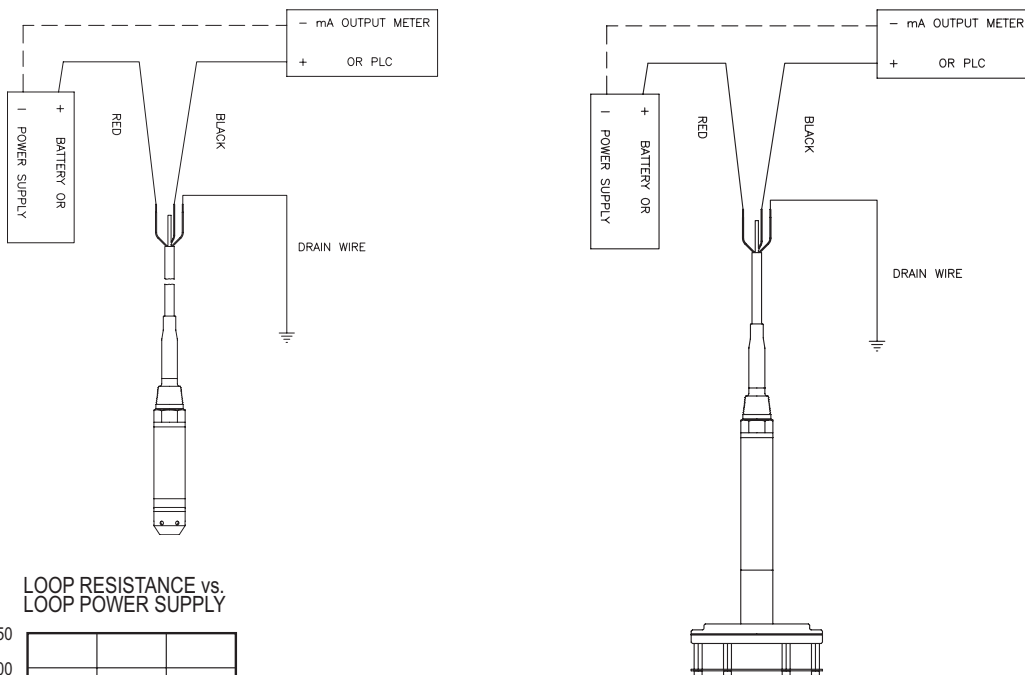

SLT1 & SLT2 Series Wiring Connection	
4-20 mA output (22AWG conductors in a shielded cable with vent tube)	
+ Excitation	Red
- Excitation	Black
Shield	Drain Wire

ProSense® SLT Series Submersible Level Transmitter Accessories



Submersible Level Transmitter Vent Filter (Desiccant)

Vent filters utilize indicating desiccant to prevent moisture from entering the vent tube and damaging transmitters with vented gage reference pressure. The desiccant will turn from blue to pink when exposed to moisture indicating the need for maintenance. This vent filter design prevents moisture from entering the vent tube for at least one year without maintenance.

Submersible Level Transmitter Vent Filter (Desiccant)						
Part No.	Description	Housing Material	Tubing Size	Connector Material	Price	Weight (lbs)
SLT-VF1	ProSense indicating desiccant vent filter, for ProSense submersible hydrostatic level transmitters	PUR (polyethylene) tube with PP (polypropylene) fittings	13in (330mm)	PEEK (Polyetheretherketone)		0.5

Dimensions

inches [mm]

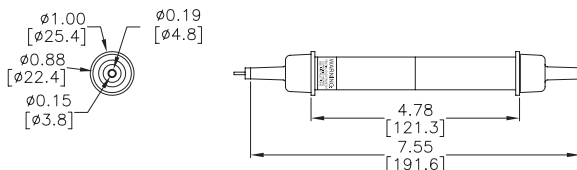

Submersible Level Transmitter Aneroid Bellows

The aneroid bellows is a maintenance-free alternative to desiccant filters for moisture protection on vented gage transmitters. Made of flexible neoprene material attached to a polycarbonate mounting bracket, the bellows fluctuates with changes in atmospheric pressure, maintaining a constant barometric reference. Note that the use of the bellows results in a closed reference pressure system subject to zero shift errors induced by changing temperatures of up to 0.003 psi/°C.



Submersible Level Transmitter Aneroid Bellows						
Part No.	Description	Housing Material	Tubing Size	Connector Material	Price	Weight (lbs)
SLT-AB1	ProSense aneroid bellows, for ProSense submersible hydrostatic level transmitters	Neoprene bellows attached to a PC (polycarbonate) bracket	12in (305mm)	PEEK (Polyetheretherketone)		0.8

Dimensions

inches [mm]

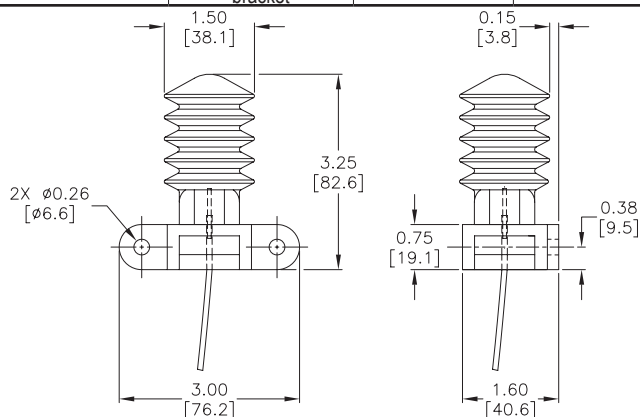

Always install a vent filter (desiccant) or aneroid bellows immediately after transmitter installation. Failure to use one or the other could result in premature failure of the transmitter, which would not be covered by warranty.

See our website www.AutomationDirect.com for complete Engineering drawings.

proSense® SLT Series Submersible Level Transmitter Accessories

Junction Boxes for Submersible Level Transmitters



The submersible level transmitter junction boxes provide a water-resistant enclosure for electrically connecting the transmitter cable to the user's system via a terminal strip. The enclosure also provides a convenient location for terminating the transmitter's vent tube to a vent filter (included in Part No. [SLT-JB1](#)) or an aneroid bellows (included in Part No. [SLT-JB2](#)). The enclosure is constructed of polycarbonate with a clear top incorporating a neoprene seal. The junction box is rated IP56.

Application

- If longer transmitter cable is needed, terminate the sensor in an [SLT-JB1](#) or [SLT-JB2](#) junction box and run standard instrumentation cable between the junction box and the measuring electronics.

ProSense Junction Boxes for Submersible Level Transmitters			
Part No.	Description	Price	Weight (lbs)
SLT-JB1	ProSense junction box for ProSense submersible hydrostatic level transmitter with SLT-VF1 indicating desiccant vent filter		2.5
SLT-JB2	ProSense junction box for ProSense submersible hydrostatic level transmitters with SLT-AB1 aneroid bellows		2.5

Dimensions

inches [mm]

Part No. [SLT-JB1](#)

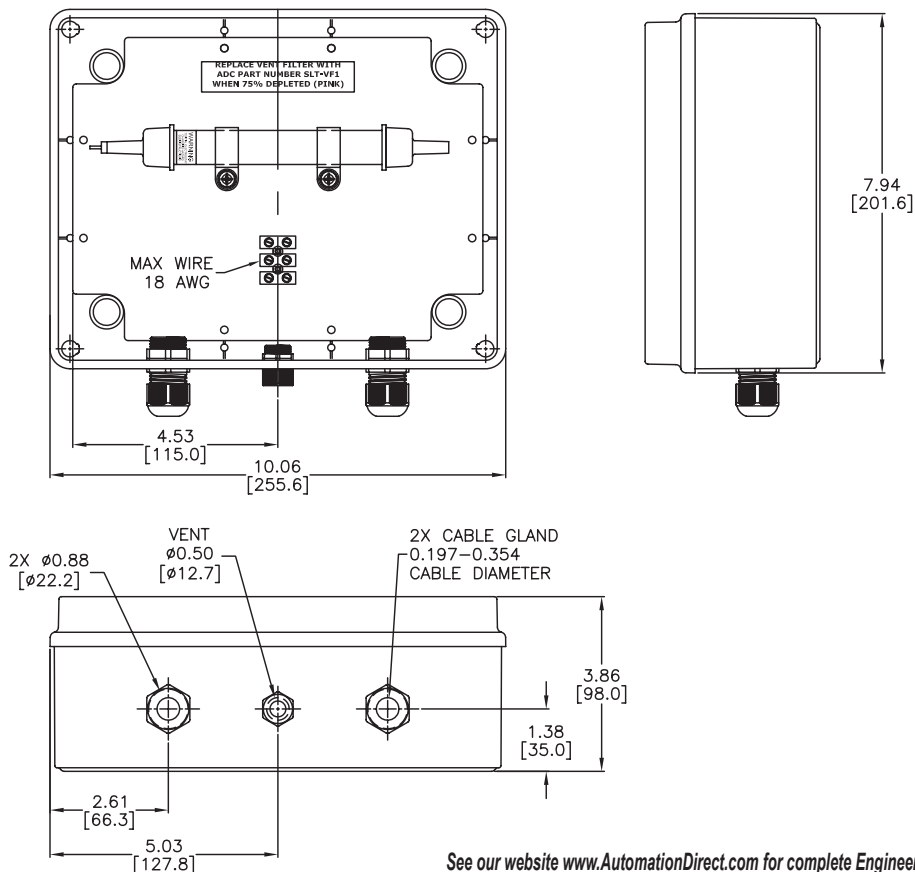

See our website www.AutomationDirect.com for complete Engineering drawings.

prosense® SLT Series Submersible Level Transmitter Accessories

Dimensions

inches [mm]

Part No. SLT-JB2

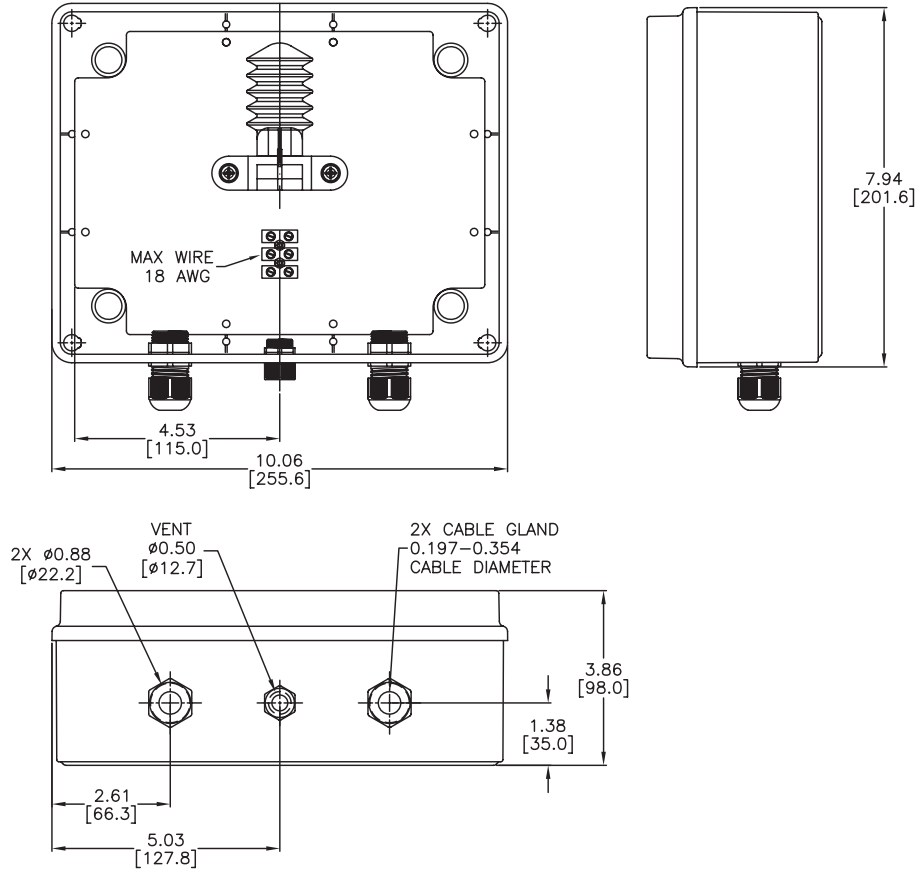

See our website www.AutomationDirect.com for complete Engineering drawings.

pro^{sense}® SLT Series Submersible Level Transmitters Accessories



Submersible Level Transmitter Replacement Ported Bullet Nose Cap

The ported bullet nose cap offers the best protection against damage to the sensing diaphragm. This single-piece nose cap allows the liquid media to enter through six 1/8" holes around the outside and includes a #8-32 UNC-2B threaded hole on the front. The closed-face nose cap is constructed of molded polyoxymethylene (POM).

Submersible Level Transmitter Replacement Ported Bullet Nose Cap			
Part No.	Description	Price	Weight (lbs)
SLT-CAP2	ProSense ported bullet nose cap, replacement, for ProSense SLT1 series submersible hydrostatic level transmitters, polyoxymethylene (POM)		0.1

Dimensions

inches [mm]

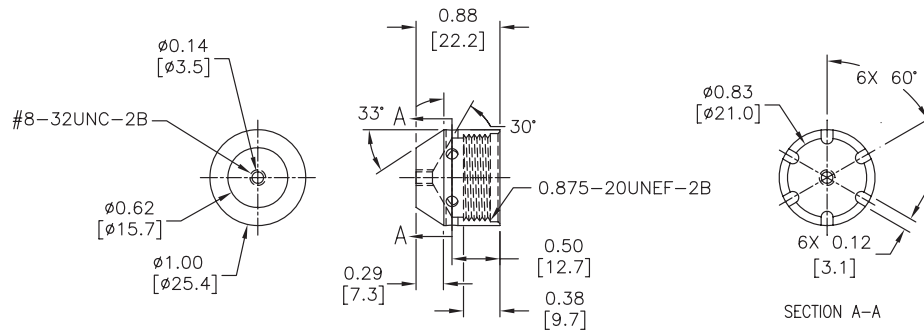

See our website www.AutomationDirect.com for complete Engineering drawings.