

**Multi-Size Lateral Brace Attachment
Fig. AF735**

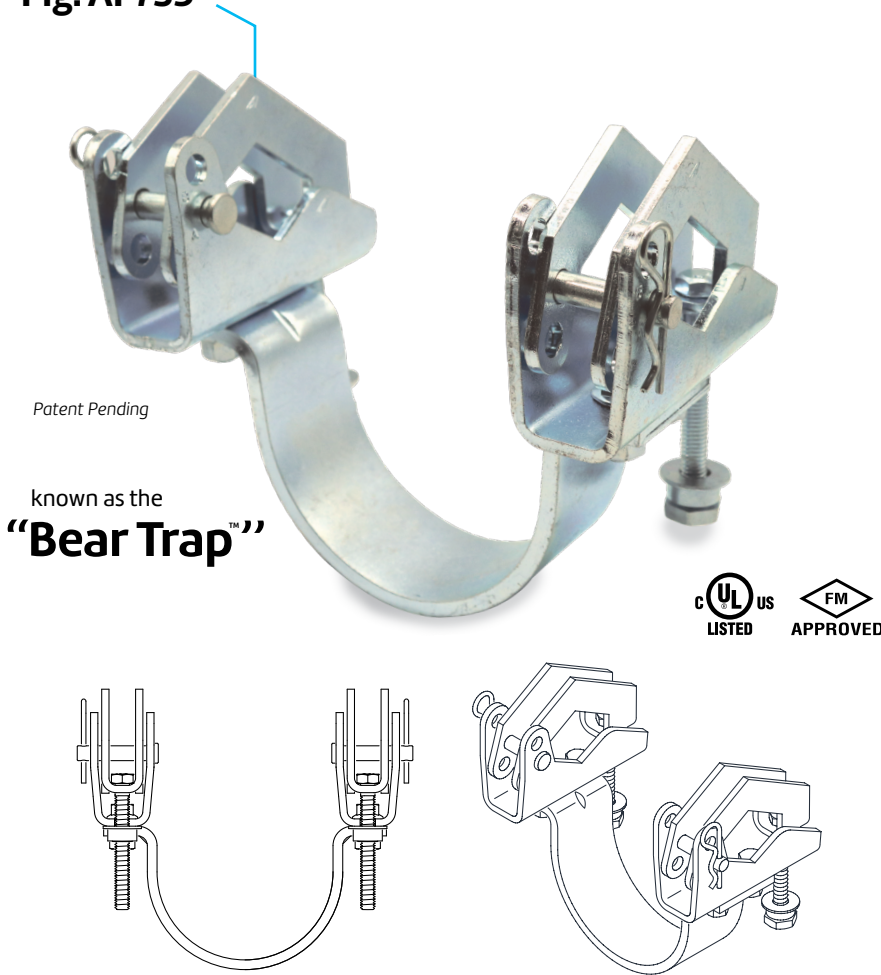

FIG. AF735: Weight

Weight (lbs.)	Service Pipe Size				
	2½"	3"	4"	6"	8"
	4.0	4.2	5.0	5.8	6.4

Notes:

ASC Engineered Solutions™ brand bracing components are designed to be compatible ONLY with other ASC Engineered Solutions brand bracing components, resulting in a Listed seismic bracing assembly. Updated UL listing information may be viewed at www.ul.com and updated FM approval information may be viewed at www.approvalguide.com.

Material Specifications

Size Range:

Service Pipe Sizes: 2 ½" - 8"
Brace Members: 1", 1-¼", 1-½", 2"

Material

Carbon Steel Jaws with Carbon Steel Strap and Hardware

Finish

Plain Electro-Galvanized per ASTM B633

Service

A seismic lateral brace designed to connect a brace member to the service pipe. The AF735 rigidly braces steel piping systems subjected to horizontal and vertical seismic loads.

Approvals

cULus Listed (ANSI/UL 203a) & FM Approved (FM 1950-13). Complies with NFPA 13, ASCE 7, IBC, & MSS SP-127 bracing requirements.

Features

- Break-off nut provides a visual indication that proper installation torque has been achieved
- Jaws allow for quick installation after brace pipe and service pipe have been installed

Ordering

Specify figure number, service pipe size, finish, and description.

Disclaimer

ASC Engineered Solutions does not provide any warranties and specifically disclaims any liability whatsoever with respect to ASC Engineered Solutions bracing products and components that are used in combination with products, parts or systems not manufactured or sold by ASC Engineered Solutions. In no event shall ASC Engineered Solutions be liable for any incidental, direct, consequential, special or indirect damages or lost profits where non-ASC Engineered Solutions bracing components have been, or are used.

Seis Brace® Seismic Fire Protection Design Tool may be accessed at www.seisbrace.com.



PROJECT INFORMATION	APPROVAL STAMP
Project:	Approved
Address:	Approved as noted
Contractor:	Not approved
Engineer:	Remarks:
Submittal Date:	
Notes 1:	
Notes 2:	

Fig. AF735 Multi-Size Lateral Brace Attachment

FIG. AF735 cULus Listing per ANSI/UL 203a (ASD)

Service Pipe Size	Standard Service Pipe	Specialty Service Pipe	Horizontal Load Rating at Brace Angle			
			30°- 44°	45°- 59°	60°- 90°	Listed
			lbf/kN	lbf/kN	lbf/kN	
2½"		Mega-Flow Eddy Flow Fire-Flow Hydroflow				
3"	Sch. 10 Sch. 40	Mega-Flow Eddy Flow Fire-Flow Hydroflow				
4"		Mega-Flow Eddy Flow Fire-Flow Hydroflow	942 4.19	1333 5.93	1632 7.26	1885 8.38
6"		Mega-Flow				
8"	0.188" Wall Sch. 30					

- 1) Brace Angles are determined from Vertical.
- 2) Sch. 10 & 0.188" Wall Load Ratings may be used for any thicker wall pipe of the same diameter.
- 3) Listed load ratings reduced for angle ranges in accordance with NFPA 13-2019 Table 18.5.2.3.
- 4) Load Ratings reflect 1" - 2" brace members.
- 5) Minimum safety factor of 2.2 in accordance with NFPA 13-2019 Section A.18.5.2.3.

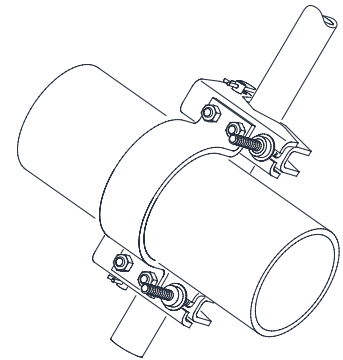

Lateral Application

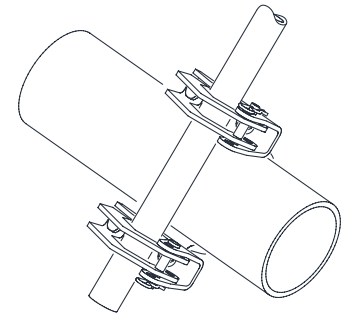

Lateral Application

FIG. AF735 FM Approved (Listing) per FM 1950-13 (ASD)

Service Pipe Size	Standard Service Pipe	Specialty Service Pipe	Horizontal Load Rating at Brace Angle			
			30°- 44°	45°- 59°	60°- 74°	75°- 90°
			lbf/kN	lbf/kN	lbf/kN	lbf/kN
2½"		Mega-Flow Eddy Flow Fire-Flow Hydroflow	1780 7.91	2510 11.16	3080 13.70	3440 15.30
3"	Sch. 10 Sch. 40	Mega-Flow Eddy Flow Fire-Flow Hydroflow	1670 7.42	2360 10.49	2890 12.85	3230 14.36
4"		Mega-Flow Eddy Flow Fire-Flow Hydroflow	1660 7.38	2350 10.45	2880 12.81	3210 14.27
6"		Mega-Flow	1400 6.22	1990 8.85	2440 10.85	2720 12.09
8"	0.188" Wall Sch. 30	-	1050 4.67	1490 6.62	1830 8.14	2040 9.07

- 1) Brace Angles are determined from Vertical.
- 2) Sch. 10 & 0.188" Wall Load Ratings may be used for any thicker wall pipe of the same diameter.
- 3) See table below for FM listed specialty pipes & FM Listed metric service pipes.
- 4) Load Ratings reflect 1" - 2" brace members. See table below for listed brace members.
- 5) Load ratings include a minimum safety factor of 1.5 in accordance with NFPA 13-2016 Section A.9.3.5.2.3. To convert the load ratings above to a safety factor of 2.2 per NFPA 13-2019 Section A.18.5.2.3, multiply load ratings by a factor of 0.68.
- 6) To convert to LRFD Load Ratings, ASD Load Ratings may be multiplied by a factor of 1.5.

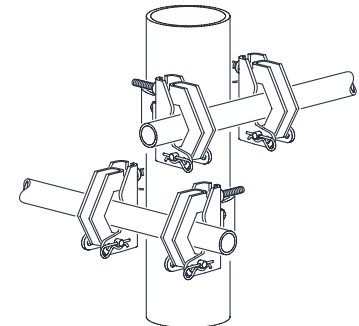

Riser Application



asc-es.com

Building connections that last™

Fig. AF735 Multi-Size Lateral Brace Attachment

- 1 Confirm hinge pin position is correct for size of brace pipe being used. For 1 inch and 1-¼ inch diameter brace pipes, make sure the hinge pin is located in hole "A" for both the bottom and top jaws. For 1-½ inch and 2 inch diameter brace pipes, change the hinge location to the hole marked as "B" on both the top and bottom jaws.
- 2 Place the AF735 around the service pipe to be braced.
- 3 Swing the top jaw over the brace pipe and have the bolt enter the slot of the bottom sheet metal jaw. Make sure the breakoff nut and washer are located on the bottom of the bottom jaw. The end of the brace pipe shall extend at least 1" (25.4 mm) past the sheet metal jaw.
- 4 Tighten the breakoff nut with a ½ inch drive, ¾ inch deep socket on both sides of the brace until they contact the bottom jaws ensuring the washer is not hanging off the edge of the bottom sheet metal jaw. Continue to tighten both nuts until their heads break off.
- 5 Ensure the brace angle is within the specified range.

Note: The brace member may be installed above or below the service pipe.

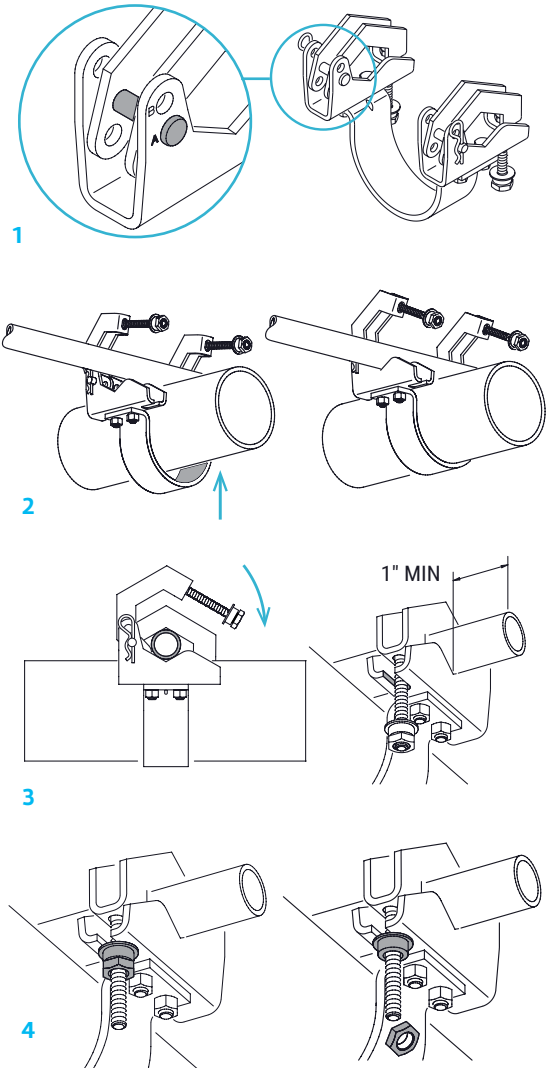
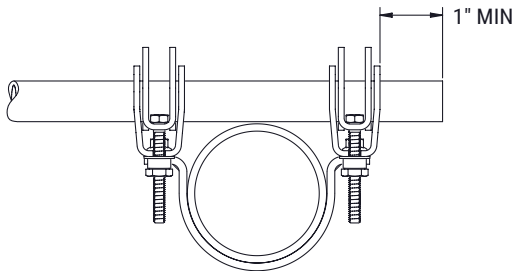

FIG. AF735 cULus & FM Approved Brace Members

Brace Member	Brace Size	Standard (or Equivalent)	UL	FM
Sch. 40 NPS Pipe	1", 1¼", 1½", 2"	ASTM A53, A106, A135, or A795	✓	✓



asc-es.com

Building connections that last™