

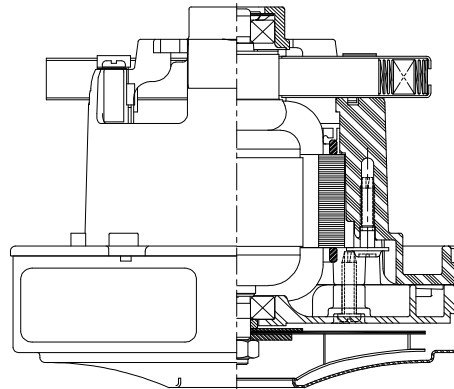

Model: 122673-00

DESCRIPTION

- One stage
- 120 volts
- 5.1"/130 mm diameter
- Double ball bearings
- Single speed
- Thru-flow discharge
- Thermost fan end bracket
- Thermost Cup bracket



SPECIAL FEATURES

- Suitable for 120 volt AC operation, 50/ 60 Hz
- UL recognized, category PRGY2 (E47185)
- CSA certified, class 1611 01 (LR31393)
- Thermostet Cup frame design
- Tapered fan system
- High airflow fan system
- The Lamb Electric vacuum motor line offers a wide range of performance levels to meet design needs
- 105C opening temperature Thermostat
- 119539-10 has brushes suitable for 400 Hz operation

DESIGN APPLICATION

- Equipment operating in environments not requiring separation of working air from motor ventilating air
- Designed to handle clean, dry, filtered air only

TYPICAL MOTOR PERFORMANCE.*

(At 120 volts, 60Hz, test data is corrected to standard conditions of 29.92 Hg, 68° F.)

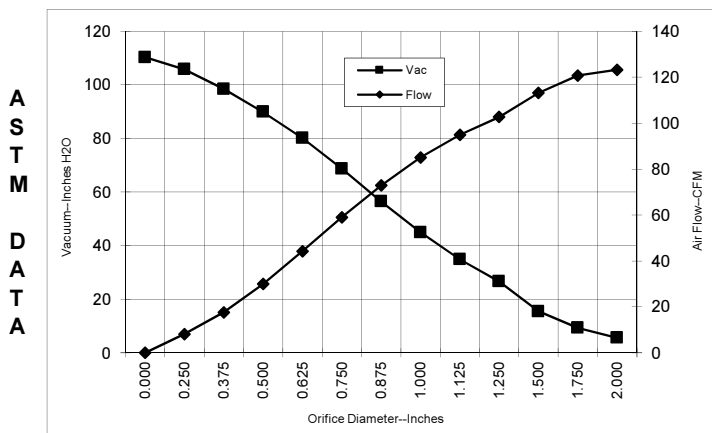

Orifice (Inches)	Amps	Watts (In)	RPM	Vac (In.H2O)	Flow (CFM)	Air Watts
2.000	10.6	1237	32033	5.6	123.3	82
1.750	10.7	1238	32005	9.3	120.7	133
1.500	10.6	1237	31988	15.4	113.2	206
1.250	10.7	1249	32087	26.7	102.7	322
1.125	10.7	1244	32108	34.9	94.9	390
1.000	10.6	1236	32332	45.0	85.0	317
0.875	10.4	1211	32688	56.5	72.9	484
0.750	10.0	1165	33387	68.7	59.0	477
0.625	9.3	1088	34335	80.2	44.2	417
0.500	8.6	1011	35737	89.9	30.0	317
0.375	7.7	908	37493	98.5	17.7	205
0.250	7.0	829	39070	105.8	8.2	102
0.000	6.5	764	40863	110.3		

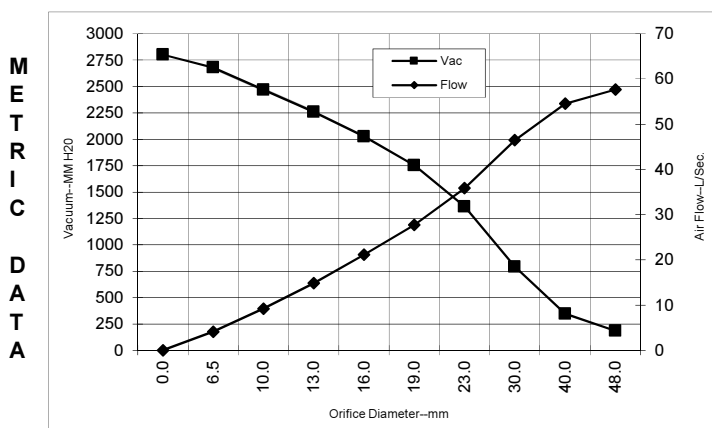

Orifice (mm)	Amps	Watts (In)	RPM	Vac (mm H2O)	Flow (L/Sec)	Air Watts
48.0	10.6	1237	32021	184	57.7	104
40.0	10.6	1237	31993	346	54.5	184
30.0	10.7	1246	32099	792	46.5	359
23.0	10.4	1217	32599	1362	35.8	442
19.0	10.0	1164	33406	1752	27.7	476
16.0	9.4	1091	34297	2025	21.2	420
13.0	8.7	1019	35597	2259	14.8	327
10.0	7.9	924	37230	2469	9.2	222
6.5	7.1	833	38991	2679	4.1	107
0.0	6.5	764	40863	2801	0.0	0

Note: Metric performance data is calculated from the ASTM data above.

* Data represents performance of a typical motor sampled from a large production quantity. Individual motor data may vary due to normal manufacturing variations.

Test Specs:	120 volts	Minimum Sealed Vacuum:	100.0	ORIFICE:	7/8 "	Minimum Vacuum:	52.0	Maximum Watts:	1320
--------------------	-----------	-------------------------------	-------	-----------------	-------	------------------------	------	-----------------------	------

DIMENSIONS

NOTES:

1. MANUFACTURER'S NAME, MODEL NUMBER, CUSTOMER PART NUMBER, VOLTAGE, FREQUENCY, INSPECTOR'S CODE, DATE OF MANUFACTURE, AGENCY RECOGNITION CODE AND PLANT LOCATION CODE TO APPEAR ASSEMBLY, LOCATION IS OPTIONAL.
2. MOUNTING MUST NOT RESTRICT THIS DIAMETER.
3. POWER LEAD: 18 GAUGE STRANDED, COLOR BLACK. GROUND LEAD: 18 GAUGE STRANDED, COLOR GREEN WITH YELLOW STRIP.

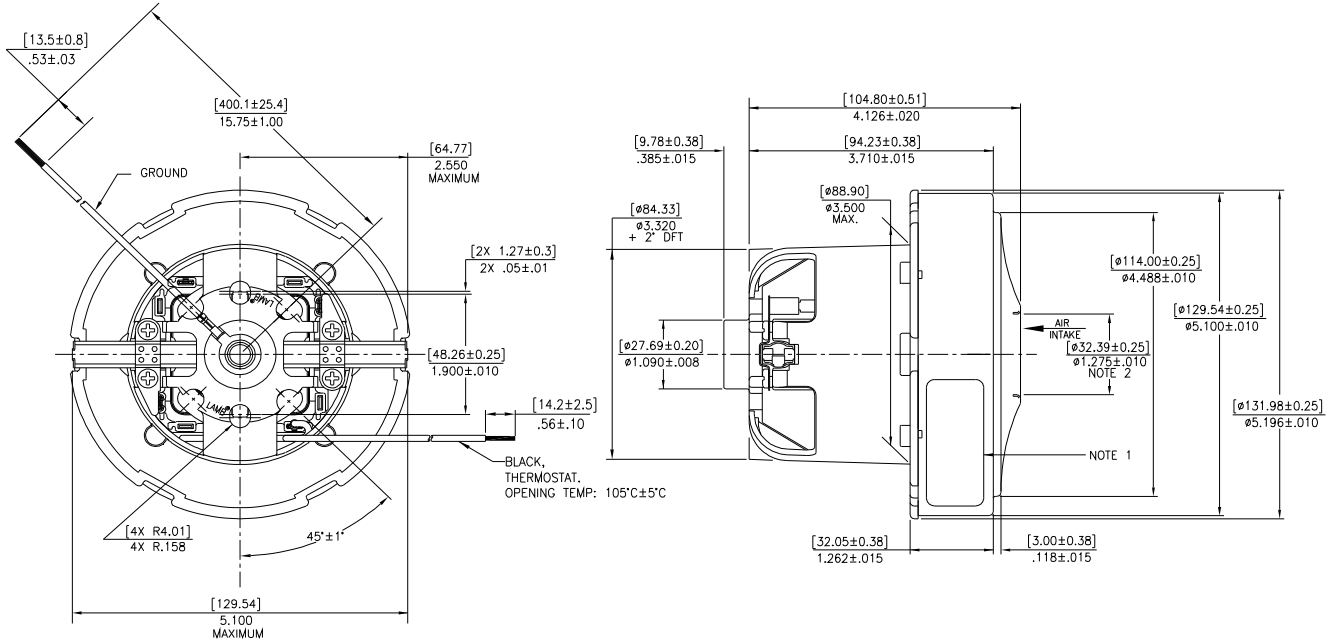

IMPORTANT NOTE: *Pictorial and dimensional data are subject to change without notice. Contact factory for current revision levels.*

WARNING - AMETEK Lamb Electric thru-flow vacuum motors must never be used in applications in which wet or moist conditions are involved, where dry chemicals or other volatile materials are present, or where airflow may be restricted or blocked. Such motors are designed to permit the vacuumed air to pass over the electrical winding to cool it. Thus any foam, liquid (including water), dry chemical, or other foreign substance coming in contact with electrical conductors could cause combustion (depending on volatility) or electrical shock. Failure to observe these precautions could result in property damage and severe personal injury, including death in extreme cases. All applications incorporating Lamb Electric motors should be submitted to Underwriters Laboratories Inc. or other appropriate organizations or agencies for testing specifically related to the safety of your equipment.

AMETEK/Floorcare & Specialty Motors
www.ametekfsm.com