



Model: 122654-00

SPECIAL FEATURES

- 1500+ Hours life (Eternity Brush)
- High Efficiency Motor/Fan
- Improved Cooling System
- Enhanced II Bearing Protection
- CAN & US UL recognition marked cRUus
- Categories PRGY2/PRGY8
- File #s E47185 & E56617 (Class B)

DESCRIPTION

- 230 volts AC
- One-stage tapered fan
- 6.6" / 162 mm diameter
- Improved sound quality
- "True" tangential discharge bracket
- High-Efficiency "Galaxy" lamination
- Double ball bearings; 10mm output

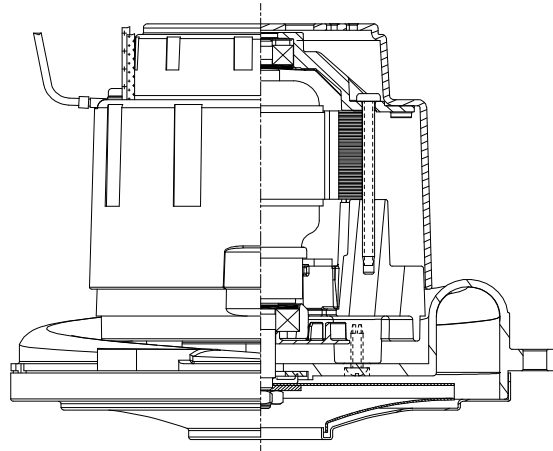

DESIGN APPLICATION

- Commercial and Residential Central Cleaning Systems
- Equipment requires separation of working air from motor ventilating air
- Designed to handle clean, dry, filtered air only

PEAK AIRWATTS
647

Calculated in accordance with ASTM F2105

TYPICAL MOTOR PERFORMANCE.*

(At 230 volts, 60Hz, test data is corrected to standard conditions of 29.92 Hg, 68° F.)

ASTM DATA

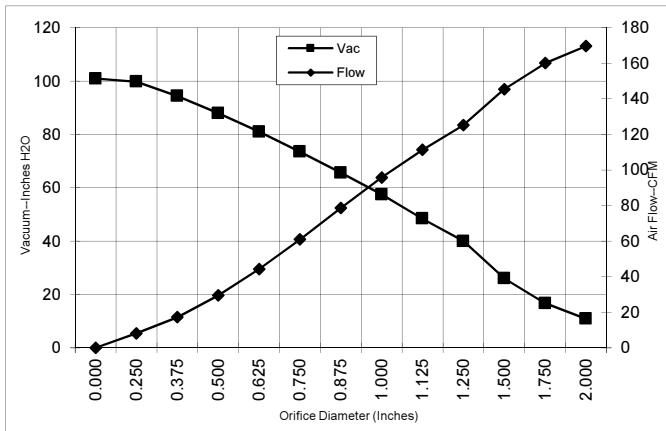

Orifice (Inches)	Amps	Watts (In)	RPM	Vac (In.H2O)	Flow (CFM)	Air Watts
2.000	7.6	1599	25466	10.9	169.6	216
1.750	7.6	1601	25438	16.7	160.1	314
1.500	7.6	1597	25437	26.0	145.5	444
1.250	7.5	1574	25592	40.0	125.3	588
1.125	7.3	1547	25788	48.4	111.4	633
1.000	7.1	1504	26106	57.5	95.8	647
0.875	6.8	1444	26625	65.6	78.6	605
0.750	6.5	1368	27270	73.5	60.9	525
0.625	6.0	1266	28274	81.0	44.3	421
0.500	5.4	1154	29391	87.9	29.5	304
0.375	4.9	1050	30624	94.3	17.2	190
0.250	4.6	980	31603	99.7	8.2	95
0.000	4.2	908	32716	100.9	0.0	0

METRIC DATA

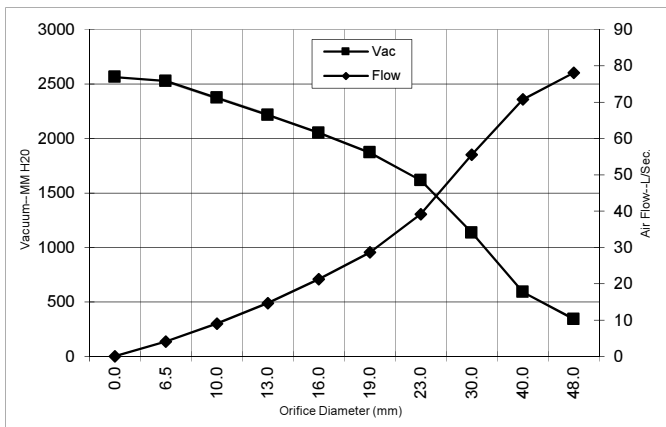

Orifice (mm)	Amps	Watts (In)	RPM	Vac (mm H2O)	Flow (L/Sec)	Air Watts
48.0	7.6	1600	25454	341	78.1	259
40.0	7.6	1599	25437	590	70.7	405
30.0	7.4	1559	25700	1133	55.5	612
23.0	6.9	1459	26495	1616	39.1	615
19.0	6.5	1366	27290	1870	28.6	523
16.0	6.0	1271	28234	2050	21.2	425
13.0	5.5	1165	29280	2216	14.6	316
10.0	5.0	1066	30439	2372	9.0	207
6.5	4.6	983	31554	2527	4.1	100
0.0	4.2	908	32716	2563	0.0	0

Note: Metric Performance data is calculated from the ASTM data above.

* Data represents performance of a typical motor sampled from a large production quantity. Individual motor data may vary due to normal manufacturing variations.

Test Specs:	230 Volts	Minimum Sealed Vacuum: 94"	ORIFICE: 7/8"	Min. Vacuum: 63"	Maximum Watts: 1630
--------------------	------------------	-----------------------------------	----------------------	-------------------------	----------------------------

DIMENSIONS



NOTES:

1. LEADS: 16GA. STRANDED, POWER LEADS BLACK, GROUNDING LEAD GREEN OR GREEN WITH YELLOW STRIPE.
2. MOTOR IDENTIFICATION: MANUFACTURER'S NAME, MODEL NUMBER, VOLTAGE, FREQUENCY, INSPECTORS CODE WITH "FF" SUFFIX, DATE OF MANUFACTURE, AGENCY RECOGNITION CODE, PLANT LOCATION CODE, PATENT PENDING* AND COUNTRY OF ORIGIN.
3. MOUNTING MUST NOT RESTRICT THIS DIAMETER.
4. ALLOW [0.0026 SO M]/4.0 SO IN. (MIN.) FOR COOLING AIR INTAKE.
5. COOLING AIR INTAKE MUST BE SEPARATED FROM COOLING AIR EXHAUST.
6. COOLING AIR EXHAUST MUST BE SEPARATED FROM VACUUM EXHAUST.

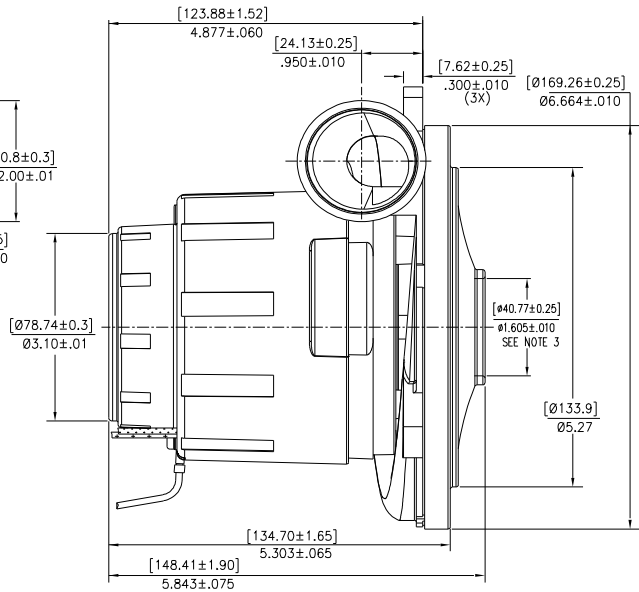
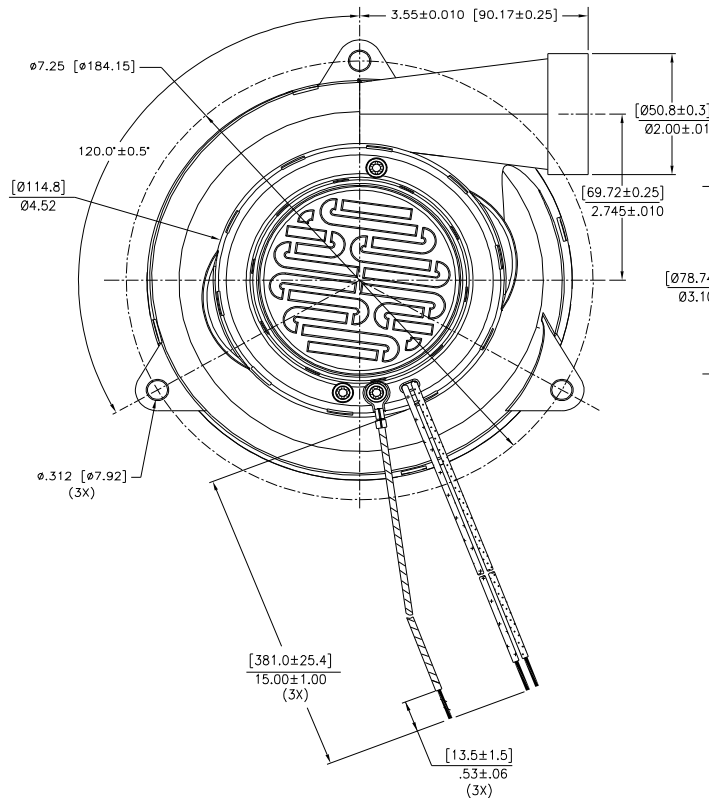

IMPORTANT NOTE: *Pictorial and dimensional data are subject to change without notice. Contact factory for current revision levels.*

WARNING - When using AMETEK Floorcare & Specialty Motors (F&SM) bypass motors in machines that come in contact with foam, liquid (including water), or other foreign substances, the machine must be designed and constructed to prevent those substances from reaching the fan system, motor housing, and electrical components. F&SM vacuum motors other than hazardous duty models should not be applied in machines that come in contact with dry chemicals or other volatile materials. Failure to observe these precautions could cause flashing (depending on volatility) or electrical shock which could result in property damage and severe bodily injury, including death in extreme cases. All applications incorporating F&SM motors should be submitted to appropriate organizations or agencies for testing specifically related to the safety of your equipment.

AMETEK Dynamic Fluid Solutions
www.ametekdfs.com