

Model: **122647-33**

SPECIAL FEATURES

- High Efficiency Motor/Fan
- Improved Cooling System
- Enhanced II Bearing Protection
- CAN & US UL recognition marked cRUus
- Categories PRGY2/PRGY8
- File #s E47185 & E56617 (Class B)
- Noise & Carbon Dust Filter Housing Included
- Same mounting pattern as Lamb's 7.2 tangential-bypass
- 33 version with terminals on leads and AI motor bracket

DESCRIPTION

- Double-stage tapered fan system
- 8.4" / 213 mm diameter
- Improved sound quality
- "True" tangential discharge bracket
- 240 volts AC
- 3.5" High-Efficiency lamination
- Double ball bearings; 10mm output

DESIGN APPLICATION

- Commercial and Residential Central Cleaning Systems
- Car wash vac and blower systems
- Equipment operating in environments requiring separation of working air from motor ventilating air
- Designed to handle clean, dry, filtered air only

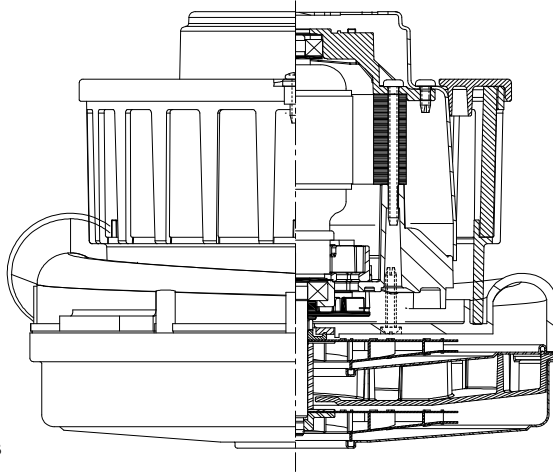

PEAK AIRWATTS
705
Calculated in accordance with ASTM F2105

TYPICAL MOTOR PERFORMANCE.*

(At 240 volts, 60Hz, test data is corrected to standard conditions of 29.92 Hg, 68° F.)

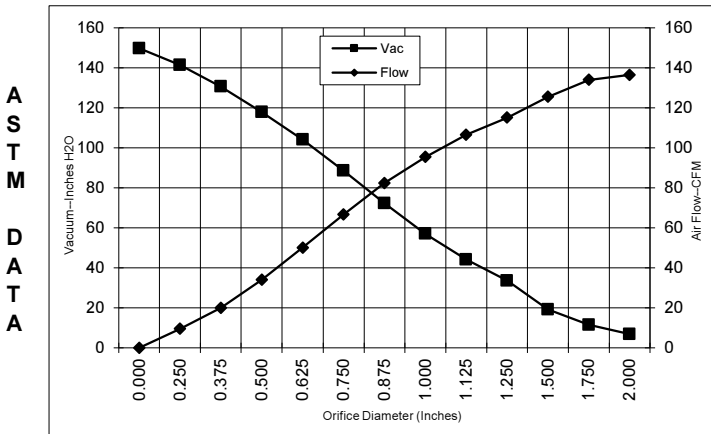

Orifice (Inches)	Amps	Watts (In)	RPM	Vac (In.H ₂ O)	Flow (CFM)	Air Watts
2.000	7.7	1689	23213	6.9	136.4	111
1.750	7.7	1700	23188	11.6	134.0	182
1.500	7.8	1708	23124	19.2	125.5	283
1.250	7.8	1720	23067	33.6	115.1	453
1.125	7.8	1721	23056	44.1	106.5	551
1.000	7.8	1708	23141	57.1	95.4	639
0.875	7.6	1685	23337	72.3	82.4	699
0.750	7.4	1632	23661	88.6	66.7	693
0.625	6.9	1530	24320	104.2	50.1	612
0.500	6.3	1399	25363	117.9	34.0	471
0.375	5.5	1250	26790	130.6	20.0	307
0.250	4.9	1118	28137	141.4	9.5	158
0.000	4.4	1018	29553	149.7	0.0	0

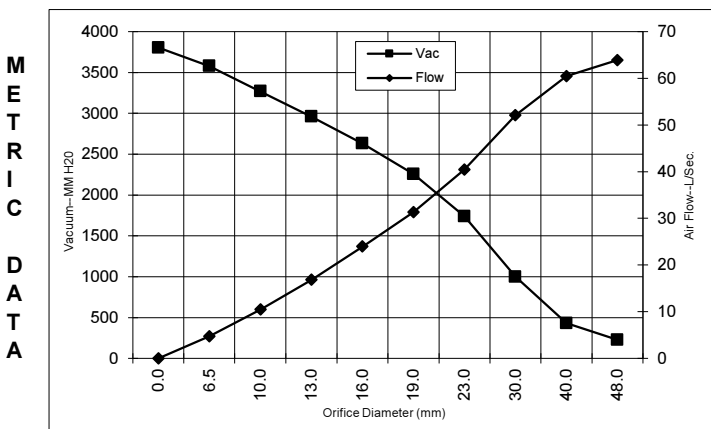

Orifice (mm)	Amps	Watts (In)	RPM	Vac (mm H ₂ O)	Flow (L/Sec)	Air Watts
48.0	7.7	1694	23202	228	63.9	142
40.0	7.7	1706	23144	430	60.4	253
30.0	7.8	1721	23061	1000	52.1	507
23.0	7.7	1691	23288	1740	40.4	684
19.0	7.4	1630	23674	2257	31.3	692
16.0	6.9	1534	24293	2630	24.0	616
13.0	6.3	1412	25259	2960	16.8	485
10.0	5.6	1272	26576	3269	10.5	332
6.5	5.0	1125	28070	3578	4.7	166
0.0	4.4	1018	29553	3802	0.0	0

Note: Metric Performance data is calculated from the ASTM data above.

* Data represents performance of a typical motor sampled from a large production quantity. Individual motor data may vary due to normal manufacturing variations.

Test Specs:	240	Minimum Sealed Vacuum: 143"	ORIFICE: 7/8"	Minimum Vacuum: 67"	Maximum Watts: 1769
-------------	-----	-----------------------------	---------------	---------------------	---------------------

DIMENSIONS



NOTES:

1. LEADS: POWER: 16GA. STRANDED, BLACK, GROUND: 16GA. STRANDED, GREEN OR GREEN AND YELLOW.
2. MOTOR IDENTIFICATION: MANUFACTURER'S NAME, MODEL NUMBER, VOLTAGE, FREQUENCY, INSPECTORS CODE WITH "FF" SUFFIX, DATE OF MANUFACTURE, AGENCY RECOGNITION CODE, PLANT LOCATION CODE, PATENT PENDING* AND COUNTRY OF ORIGIN.
3. MOUNTING MUST NOT RESTRICT THIS DIAMETER.
4. ALLOW [0.0028 SQ M]/4.0 SQ IN. (MIN.) FOR COOLING AIR INTAKE.
5. COOLING AIR INTAKE MUST BE SEPARATED FROM COOLING AIR EXHAUST.
6. COOLING AIR EXHAUST MUST BE SEPARATED FROM VACUUM EXHAUST.

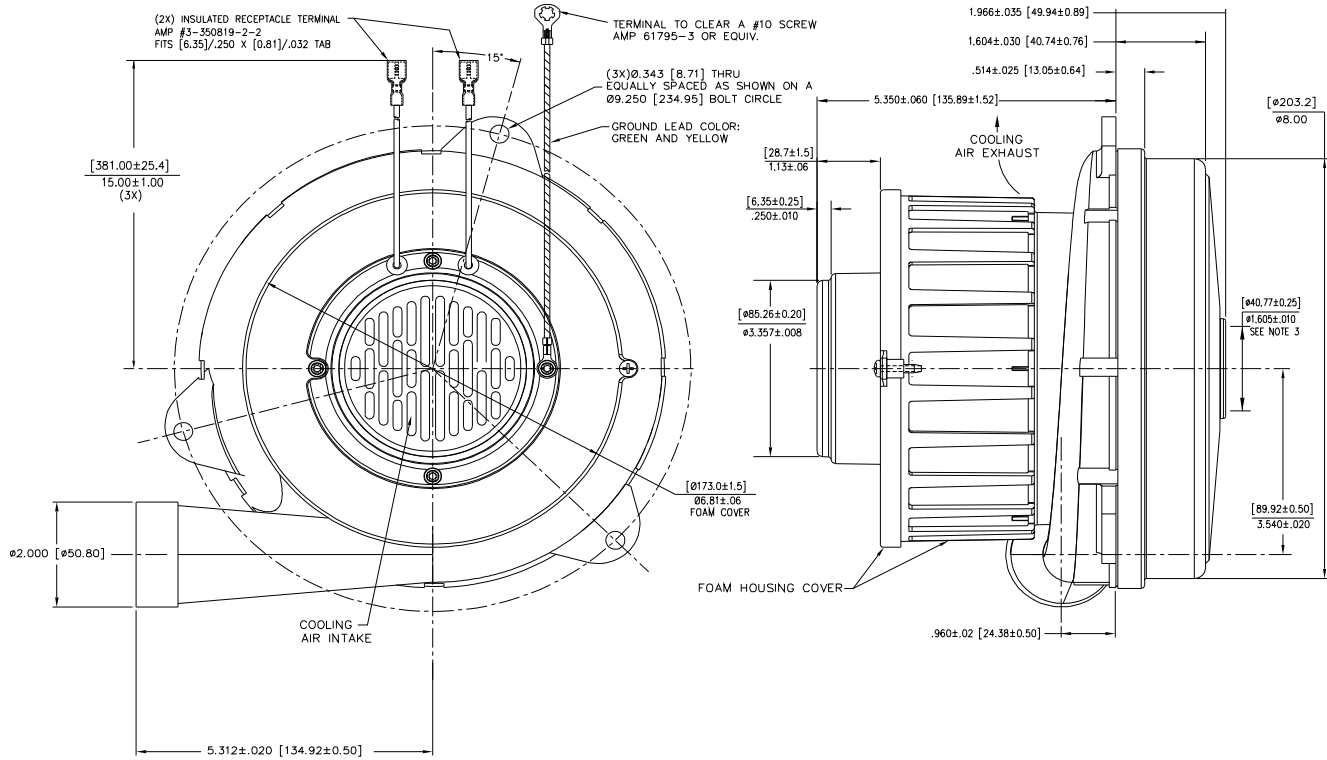

IMPORTANT NOTE: Pictorial and dimensional data are subject to change without notice. Contact factory for current revision levels.

WARNING - When using AMETEK Floorcare & Specialty Motors (F&SM) bypass motors in machines that come in contact with foam, liquid (including water), or other foreign substances, the machine must be designed and constructed to prevent those substances from reaching the fan system, motor housing, and electrical components. F&SM vacuum motors other than hazardous duty models should not be applied in machines that come in contact with dry chemicals or other volatile materials. Failure to observe these precautions could cause flashing (depending on volatility) or electrical shock which could result in property damage and severe bodily injury, including death in extreme cases. All applications incorporating F&SM motors should be submitted to appropriate organizations or agencies for testing specifically related to the safety of your equipment.

AMETEK Dynamic Fluid Solutions
www.ametekdfs.com