



Floorcare & Specialty Motors

Model: 122627-00



DESCRIPTION

- 120 volts AC
- Two-stage tapered fan
- 6.6" / 162 mm diameter
- Improved sound quality
- "True" tangential discharge bracket
- High-Efficiency "Galaxy" lamination
- Double ball bearings; 10mm output

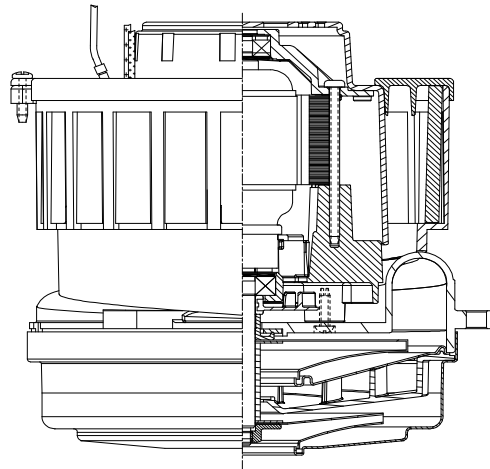

SPECIAL FEATURES

- 1500+ Hours life (Eternity Brush)
- High Efficiency Motor/Fan
- Improved Cooling System
- Enhanced II Bearing Protection
- CAN & US UL recognition marked cRUus
- Categories PRGY2/PRGY8
- File #s E47185 & E56617 (Class B)
- Noise & Carbon Dust Filter Housing Included
- 07 version with terminals on leads

DESIGN APPLICATION

- Commercial and Residential Central Cleaning Systems
- Car wash vac and blower systems
- Equipment operating in environments requiring separation of working air from motor ventilating air
- Designed to handle clean, dry, filtered air only

PEAK AIRWATTS
659
Calculated in accordance with ASTM F2105

TYPICAL MOTOR PERFORMANCE.*

(At 120 volts, 60Hz, test data is corrected to standard conditions of 29.92 Hg, 68° F.)

ASTM DATA

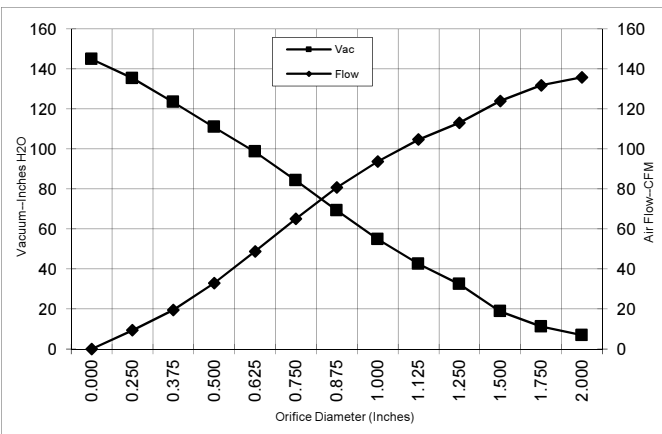

Orifice (Inches)	Amps	Watts (In)	RPM	Vac (In.H ₂ O)	Flow (CFM)	Air Watts
2.000	13.8	1560	22842	6.9	135.8	110
1.750	13.9	1566	22820	11.2	131.8	173
1.500	13.9	1572	22717	18.8	124.0	273
1.250	14.1	1586	22619	32.4	113.1	430
1.125	14.1	1587	22629	42.6	104.7	524
1.000	14.1	1582	22636	54.9	93.7	603
0.875	13.8	1558	22808	69.3	80.7	656
0.750	13.4	1508	23137	84.2	65.1	643
0.625	12.6	1420	23816	98.6	48.8	564
0.500	11.4	1290	24886	111.0	33.0	430
0.375	10.0	1135	26315	123.4	19.5	283
0.250	8.7	1002	27839	135.3	9.4	148
0.000	7.8	905	29308	144.9	0.0	0

METRIC DATA

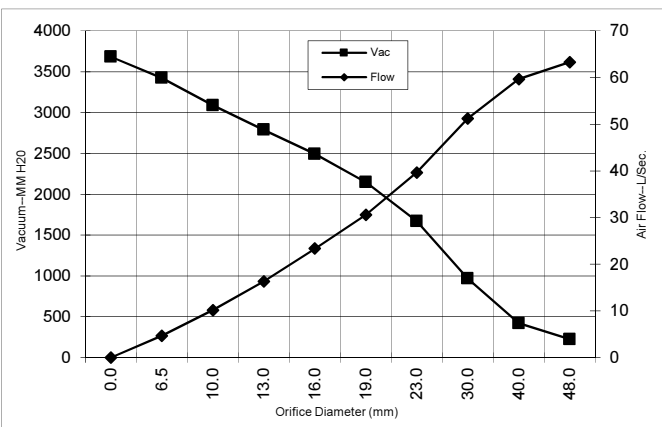

Orifice (mm)	Amps	Watts (In)	RPM	Vac (mm H ₂ O)	Flow (L/Sec)	Air Watts
48.0	13.9	1563	22832	223	63.3	138
40.0	13.9	1570	22748	420	59.6	243
30.0	14.1	1587	22625	965	51.2	482
23.0	13.9	1564	22765	1669	39.6	643
19.0	13.4	1506	23151	2146	30.6	641
16.0	12.6	1423	23789	2490	23.3	567
13.0	11.5	1303	24779	2787	16.3	443
10.0	10.2	1158	26101	3087	10.2	305
6.5	8.8	1009	27763	3422	4.7	155
0.0	7.8	905	29308	3680	0.0	0

Note: Metric Performance data is calculated from the ASTM data above.

* Data represents performance of a typical motor sampled from a large production quantity. Individual motor data may vary due to normal manufacturing variations.

Test Specs:	120-Volts	Minimum Sealed Vacuum:	140.0	ORIFICE:	7/8"	Min. Vacuum:	64.0	Maximum Watts:	1650
-------------	-----------	------------------------	-------	----------	------	--------------	------	----------------	------

DIMENSIONS

NOTES:

1. LEADS: 18GA. STRANDED. POWER LEADS BLACK AND WHITE. GROUNDING LEAD GREEN OR GREEN WITH YELLOW STRIPE.
2. MOTOR IDENTIFICATION: MANUFACTURER'S NAME, MODEL NUMBER, VOLTAGE, FREQUENCY, INSPECTORS CODE WITH "FF" SUFFIX, DATE OF MANUFACTURE, AGENCY RECOGNITION CODE, PLANT LOCATION CODE, PATENT PENDING AND COUNTRY OF ORIGIN.
3. ALLOW [0.0026 SQ M]/4.0 SQ IN. (MIN.) FOR COOLING AIR INTAKE.
4. COOLING AIR INTAKE MUST BE SEPARATED FROM COOLING AIR EXHAUST.
5. COOLING AIR EXHAUST MUST BE SEPARATED FROM VACUUM EXHAUST.

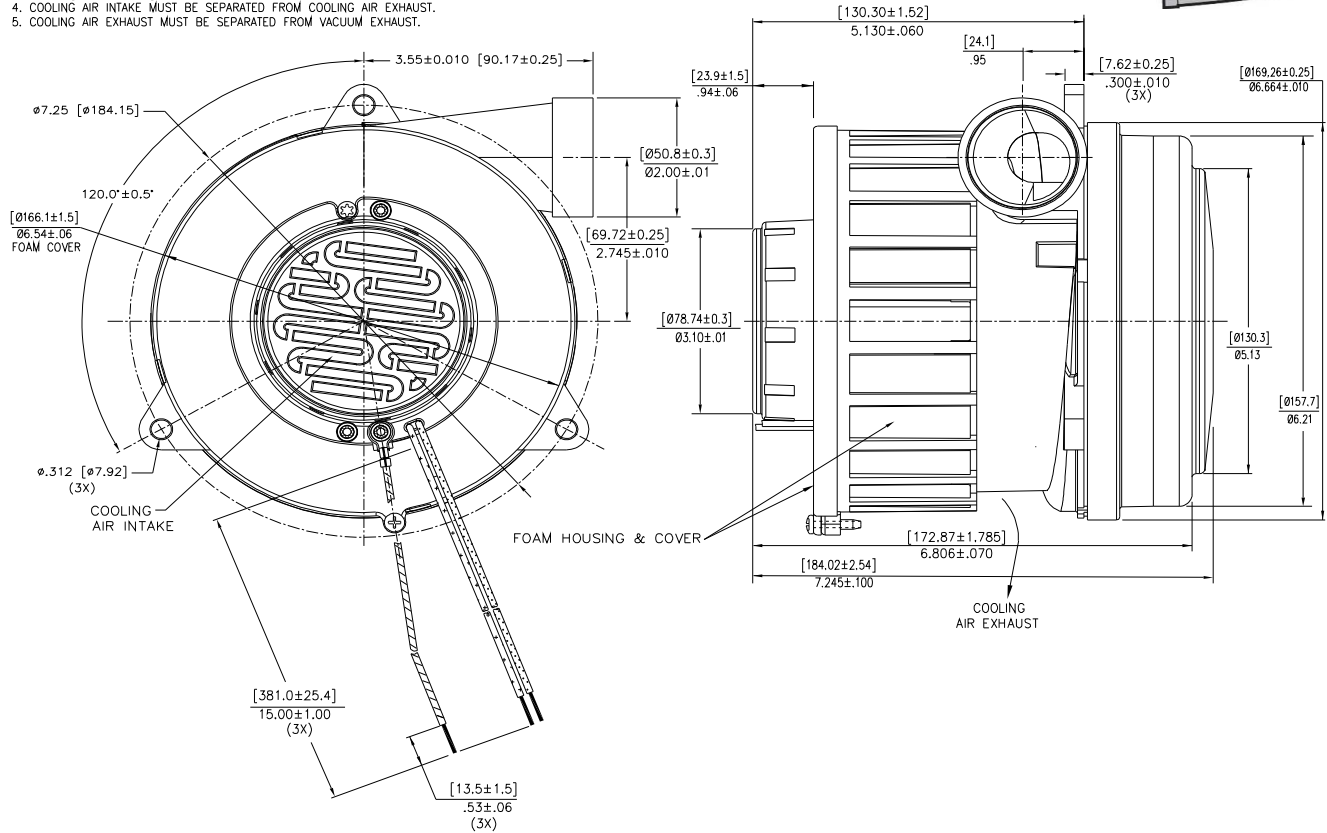

IMPORTANT NOTE: *Pictorial and dimensional data are subject to change without notice. Contact factory for current revision levels.*

WARNING - When using AMETEK Floorcare & Specialty Motors (F&SM) bypass motors in machines that come in contact with foam, liquid (including water), or other foreign substances, the machine must be designed and constructed to prevent those substances from reaching the fan system, motor housing, and electrical components. F&SM vacuum motors other than hazardous duty models should not be applied in machines that come in contact with dry chemicals or other volatile materials. Failure to observe these precautions could cause flashing (depending on volatility) or electrical shock which could result in property damage and severe bodily injury, including death in extreme cases. All applications incorporating F&SM motors should be submitted to appropriate organizations or agencies for testing specifically related to the safety of your equipment.

AMETEK Dynamic Fluid Solutions
www.ametekdfs.com