



Floorcare & Specialty Motors

Model: 122593-04



DESCRIPTION

- 120 volts AC
- Two-stage tapered fan
- 6.6" / 162 mm diameter
- Improved sound quality
- "True" tangential discharge bracket
- High-Efficiency "Galaxy" lamination
- Double ball bearings; 10mm output

DESIGN APPLICATION

- Commercial and Residential Central Cleaning Systems
- Car wash vac and blower systems
- Equipment operating in environments requiring separation of working air from motor ventilating air
- Designed to handle clean, dry, filtered air only

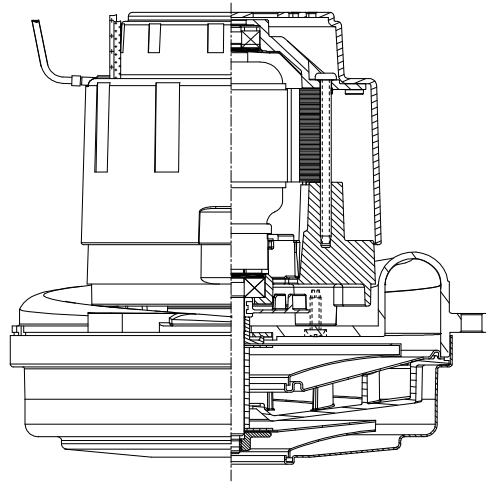

SPECIAL FEATURES

- 3000+ Avg hours life (curved brush)
- Up to 40% Overall Efficiency
- High efficient cooling system
- Lamb "Green Power Label"
- UL & cUL recognized, category PRGY2 (E47185)
- Locked-rotor, blocked cooling air and running overload protection
- New patent-pending bearing protection for wet applications.

**PEAK AIRWATTS
456**

Calculated in accordance with ASTM F2105

TYPICAL MOTOR PERFORMANCE.*

(At 120 volts, 60Hz, test data is corrected to standard conditions of 29.92 Hg, 68° F.)

ASTM DATA

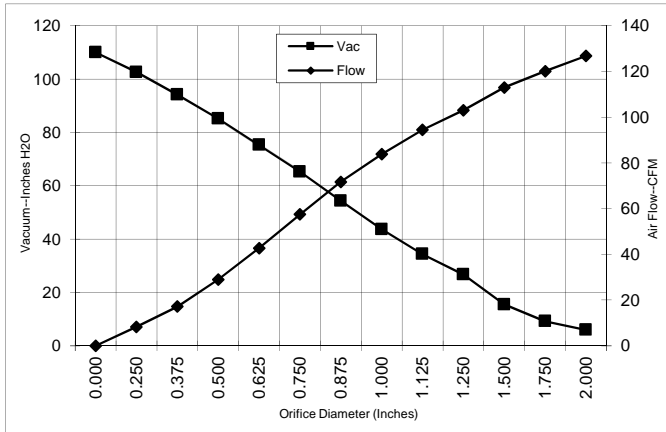

Orifice (Inches)	Amps	Watts (In)	RPM	Vac (In.H2O)	Flow (CFM)	Air Watts
2.000	9.6	1087	20729	6.0	126.8	89
1.750	9.7	1092	20751	9.2	120.1	130
1.500	9.7	1089	20659	15.5	113.0	205
1.250	9.8	1105	20614	26.7	103.0	323
1.125	9.8	1108	20524	34.4	94.5	381
1.000	9.9	1115	20517	43.7	83.8	430
0.875	9.8	1099	20637	54.4	71.6	457
0.750	9.4	1066	20993	65.2	57.5	440
0.625	8.8	1002	21612	75.3	42.7	378
0.500	8.1	922	22584	85.2	29.0	290
0.375	7.1	820	23821	94.1	17.2	190
0.250	6.5	750	25029	102.6	8.3	99
0.000	5.9	686	26243	110.0	0.0	0

METRIC DATA

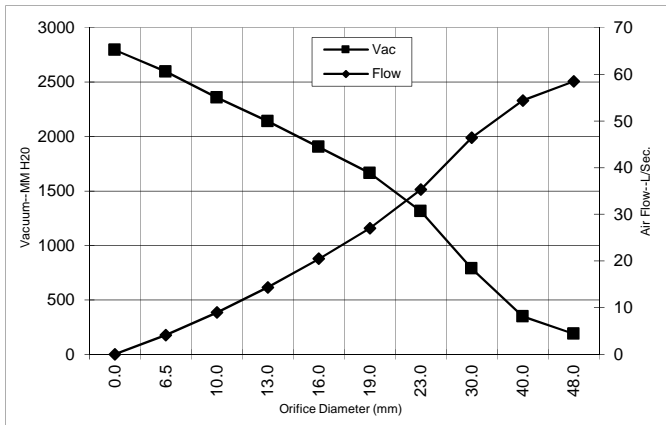

Orifice (mm)	Amps	Watts (In)	RPM	Vac (mm H2O)	Flow (L/Sec)	Air Watts
48.0	9.7	1089	20738	188	58.5	107
40.0	9.7	1090	20687	346	54.3	183
30.0	9.8	1106	20565	786	46.4	355
23.0	9.8	1103	20607	1313	35.3	450
19.0	9.4	1064	21005	1662	27.0	439
16.0	8.9	1005	21588	1902	20.5	380
13.0	8.2	930	22487	2139	14.3	299
10.0	7.3	835	23636	2356	8.9	205
6.5	6.5	753	24969	2595	4.1	104
0.0	5.9	686	26243	2793	0.0	0

Note: Metric Performance data is calculated from the ASTM data above.

* Data represents performance of a typical motor sampled from a large production quantity. Individual motor data may vary due to normal manufacturing variations.

Test Specs:	120 Volts	Minimum Sealed Vacuum: 106"	ORIFICE: 7/8"	Min. Vacuum: 52"	Maximum Watts: 1260
--------------------	-----------	-----------------------------	---------------	------------------	---------------------

DIMENSIONS



NOTES:

1. LEADS: 18GA. STRANDED, POWER LEADS BLACK AND WHITE, GROUNDING LEAD GREEN OR GREEN WITH YELLOW STRIPE.
2. MOTOR IDENTIFICATION: MANUFACTURER'S NAME, MODEL NUMBER, VOLTAGE, FREQUENCY, INSPECTORS CODE WITH "FF" SUFFIX, DATE OF MANUFACTURE, AGENCY RECOGNITION CODE, PLANT LOCATION CODE, PATENT PENDING* AND COUNTRY OF ORIGIN.
3. ALLOW [0.0026 SQ MI]/4.0 SQ IN. (MIN.) FOR COOLING AIR INTAKE.
4. COOLING AIR INTAKE MUST BE SEPARATED FROM COOLING AIR EXHAUST.
5. COOLING AIR EXHAUST MUST BE SEPARATED FROM VACUUM EXHAUST.

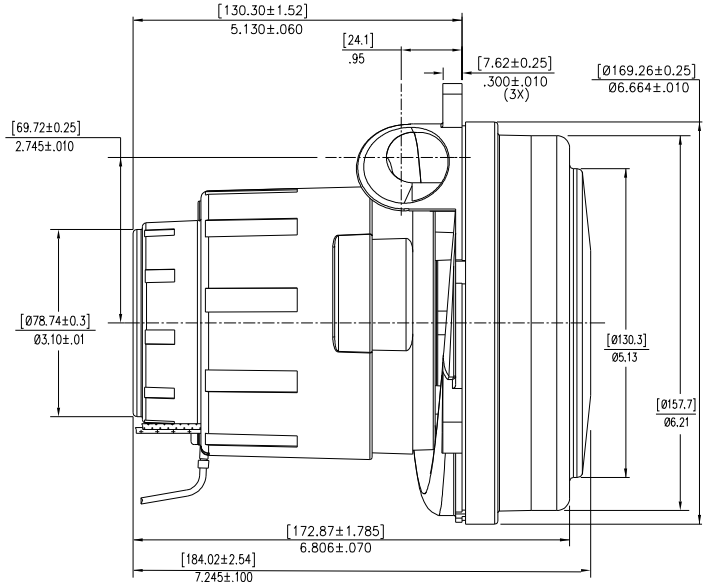
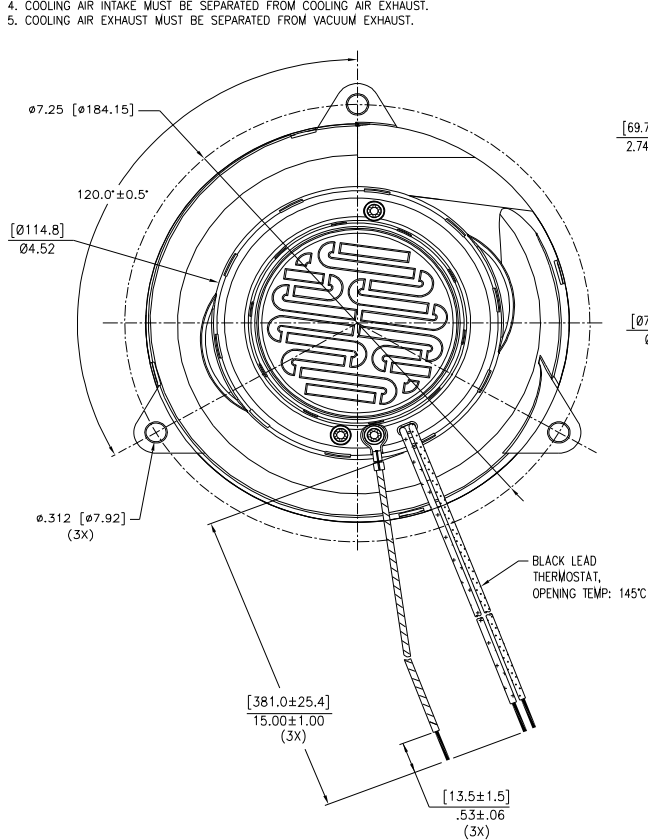

IMPORTANT NOTE: Pictorial and dimensional data are subject to change without notice. Contact factory for current revision levels.

WARNING - When using AMETEK Floorcare & Specialty Motors (F&SM) bypass motors in machines that come in contact with foam, liquid (including water), or other foreign substances, the machine must be designed and constructed to prevent those substances from reaching the fan system, motor housing, and electrical components. F&SM vacuum motors other than hazardous duty models should not be applied in machines that come in contact with dry chemicals or other volatile materials. Failure to observe these precautions could cause flashing (depending on volatility) or electrical shock which could result in property damage and severe bodily injury, including death in extreme cases. All applications incorporating F&SM motors should be submitted to appropriate organizations or agencies for testing specifically related to the safety of your equipment.

AMETEK/Floorcare & Specialty Motors
www.ametekfsm.com

Revised October 2016