



Floorcare & Specialty Motors

Product Bulletin

Model: 122568-00

Planned Configuration

- Three stage
- 240 volts
- 5.7"/145 mm diameter
- Double ball bearings
- Single speed
- Tangential bypass discharge
- Aluminum fan end bracket

DESIGN APPLICATION

- Equipment operating in environments requiring separation of working air from motor ventilating air
- Designed to handle clean, dry, filtered air only

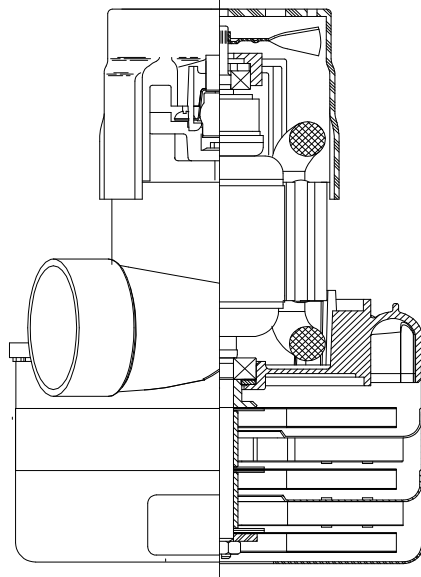

Planned Features

- Suitable for 240 volt AC operation, 50/ 60 Hz
- UL recognized, category PRGY2 (E47185)
- Provision for grounding
- Open frame design
- 10mm shaft and bearing system
- Aluminum fan end bracket designed to dampen vibration and improve durability
- The Lamb Electric vacuum motor line offers a wide range of performance levels to meet design needs

TYPICAL MOTOR PERFORMANCE.*

(At 240 volts, 60Hz, test data is corrected to standard conditions of 29.92 Hg, 68° F.)

ASTM DATA

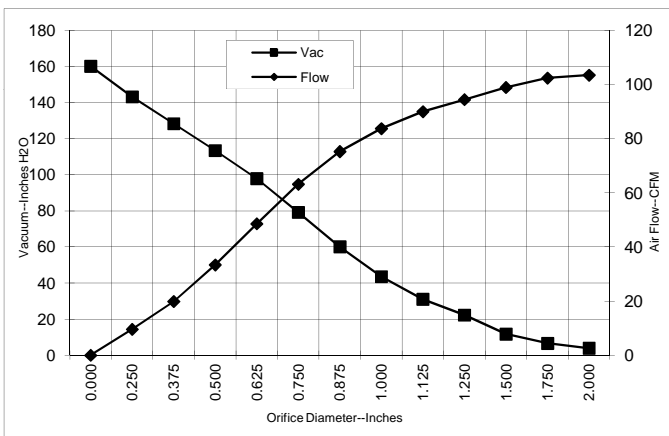

Orifice (Inches)	Amps	Watts (In)	RPM	Vac (In.H2O)	Flow (CFM)	Air Watts
2.000	8.2	1858.655	23822	3.9	103.5	48
1.750	8.3	1866.547	23773	6.6	102.4	80
1.500	8.3	1871.792	23777	11.8	98.9	137
1.250	8.4	1880.805	23697	22.3	94.4	247
1.125	8.4	1881.263	23675	31.1	90.0	328
1.000	8.4	1890.48	23631	43.6	83.8	428
0.875	8.4	1891.6	23593	60.1	75.3	531
0.750	8.3	1870.519	23748	79.2	63.2	588
0.625	8.0	1796.124	24151	97.9	48.6	558
0.500	7.3	1660.879	24986	113.4	33.4	444
0.375	6.6	1506.386	26078	128.3	19.9	299
0.250	5.9	1360.854	27257	143.2	9.6	161
0.000	5.4	1240.783	28526	160.2	0.0	0

METRIC DATA

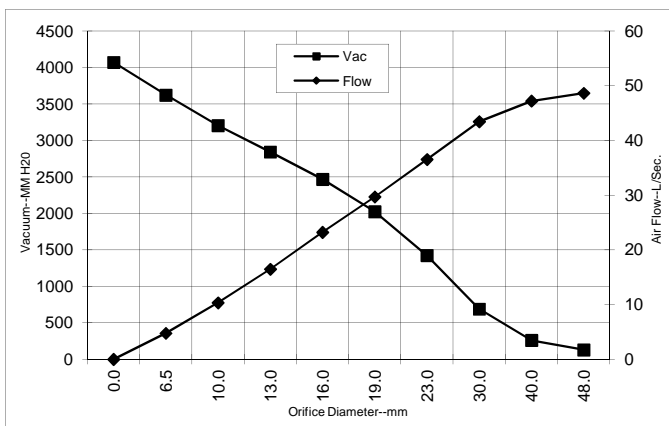

Orifice (mm)	Amps	Watts (In)	RPM	Vac (mm H2O)	Flow (L/Sec)	Air Watts
48.0	8.3	1862	23800	130	48.6	62
40.0	8.3	1870	23776	260	47.2	120
30.0	8.4	1881	23685	689	43.4	292
23.0	8.4	1891	23603	1422	36.5	505
19.0	8.3	1869	23756	2022	29.7	587
16.0	8.0	1799	24135	2467	23.2	559
13.0	7.4	1674	24902	2841	16.5	456
10.0	6.7	1530	25914	3203	10.3	321
6.5	6.0	1368	27198	3619	4.8	168
0.0	5.4	1241	28526	4069	0.0	0

Note: Metric performance data is calculated from the ASTM data above.

*** PLEASE NOTE: Data represents performance of a development motor from engineering tests. Final published Product Bulletin will use typical performance of samples from a large manufacturing quantity.**

Test Specs:	240V	Minimum Sealed Vacuum: 152"	ORIFICE:	7/8 "	Minimum Vacuum: 54"	Maximum Watts:	1920
-------------	------	-----------------------------	----------	-------	---------------------	----------------	------

DIMENSIONS

- NOTES:
 1. LEADS: 18GA STRANDED, LEADS CAN BE ANY COLOR EXCEPT GREEN OR GREEN WITH YELLOW STRIPE.
 2. GROUNDING OR EARTHING PROVISIONS: USE HOLES AS INDICATED FOR GROUNDING OR EARTHING.
 REFER TO APPROPRIATE LISTING OR REGULATORY AGENCY FOR PROPER METHOD OF GROUNDING OR EARTHING.
 3. MOTOR IDENTIFICATION: MANUFACTURER'S NAME, MODEL NUMBER, VOLTAGE, FREQUENCY, INSPECTORS CODE, DATE OF MANUFACTURE, AGENCY RECOGNITION CODE, PLANT LOCATION CODE, PATENT INFORMATION *ONE OR MORE OF THE FOLLOWING PATENTS APPLY TO THIS MOTOR: 5482378; 5736805; 4669952; 4684835* AND COUNTRY OF ORIGIN.
 4. ALLOW [0.0016 SQ M]/2.5 SQ IN. MIN. FOR COOLING AIR INTAKE.
 5. COOLING AIR INTAKE MUST BE SEPARATED FROM COOLING AIR EXHAUST.
 6. VACUUM EXHAUST MUST BE SEPARATED FROM COOLING EXHAUST.
 7. MOUNTING MUST NOT RESTRICT THIS DIAMETER.

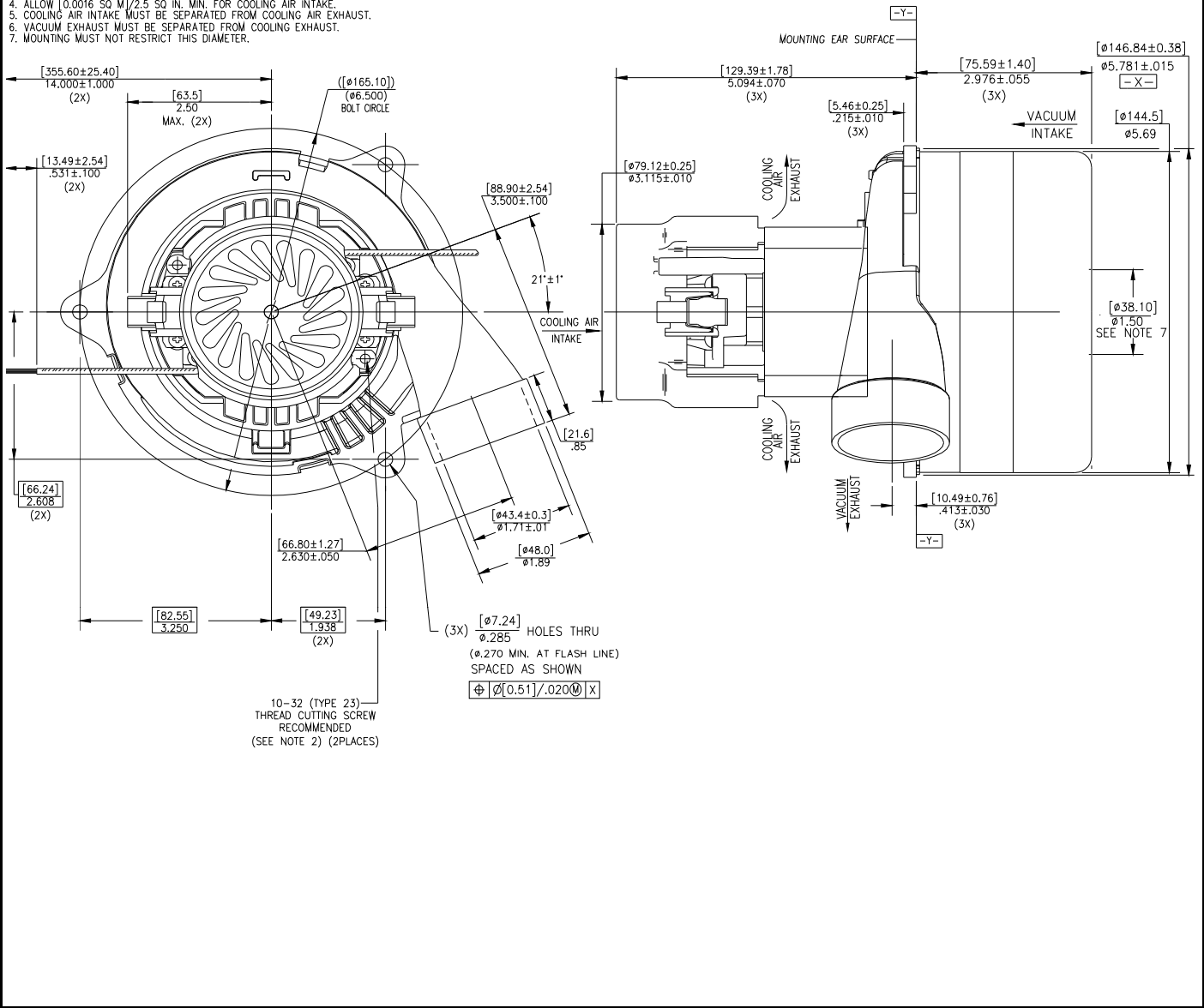

WARNING - When using AMETEK Floorcare & Specialty Motors (F&SM) bypass motors in machines that come in contact with foam, liquid (including water), or other foreign substances, the machine must be designed and constructed to prevent those substances from reaching the fan system, motor housing, and electrical components. F&SM vacuum motors other than hazardous duty models should not be applied in machines that come in contact with dry chemicals or other volatile materials. Failure to observe these precautions could cause flashing (depending on volatility) or electrical shock which could result in property damage and severe bodily injury, including death in extreme cases. All applications incorporating F&SM motors should be submitted to appropriate organizations or agencies for testing specifically related to the safety of your equipment.

AMETEK/Floorcare & Specialty Motors
www.ametekfsm.com