

Lamb® 8.4" Bypass Tangential Vacuum Motors

MECHANICAL

DIAMETER: 8.4" (213 mm)
DISCHARGE TYPE: Bypass
DISCHARGE: "True" Tangential

PERFORMANCE

STAGES: 2
SPEED: Single

DESIGN APPLICATIONS

- Commercial and Residential Central Cleaning Systems
- Car wash vac and blower systems
- Equipment operating in environments requiring separation of working air from motor ventilating air
- Designed to handle clean, dry, filtered air only

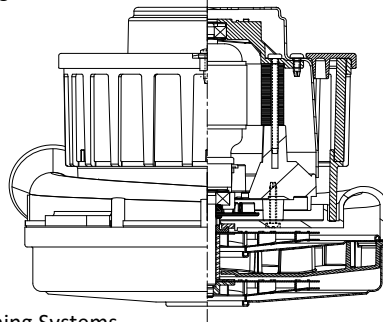

Model: 122501-00

ELECTRICAL

OPERATING INPUT VOLTAGE: 120 volts AC

FEATURES

- Improve Sound Quality
- High Efficiency Performance
- 1500+ Hours Life with Eternity Brushes
- Same mounting pattern as Lamb's 7.2 tangential-bypass

REGULATORY CERTIFICATIONS

cRUUs recognized, category PRGY2/8 (E47185)
Class B (E56617)

**PEAK AIRWATTS
710**

Calculated in accordance with ASTM F2105

TYPICAL MOTOR PERFORMANCE.*

(At 120 volts, 60Hz, test data is corrected to standard conditions of 29.92 Hg, 68° F.)

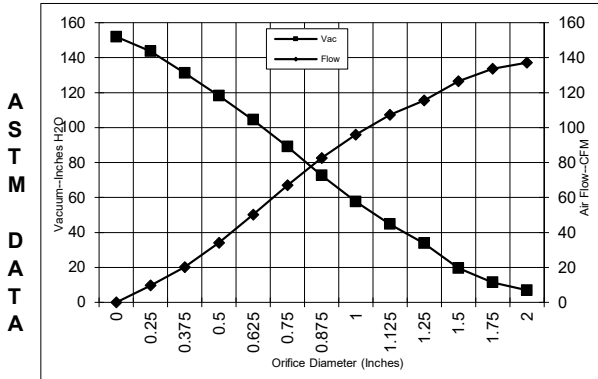

Orifice (Inches)	Amps	Watts (In)	RPM	Vac (In.H2O)	Flow (CFM)	Air Watts
2.000	15.0	1701	23021	7.0	137.1	113
1.750	15.1	1704	22972	11.5	133.6	180
1.500	15.1	1711	22923	19.5	126.5	290
1.250	15.3	1725	22824	33.8	115.5	458
1.125	15.2	1721	22849	44.8	107.3	564
1.000	15.1	1709	22923	57.6	95.9	649
0.875	14.8	1674	23145	72.7	82.6	704
0.750	14.3	1617	23465	89.1	66.9	700
0.625	13.4	1522	24229	104.5	50.2	615
0.500	12.1	1379	25289	118.3	34.1	473
0.375	10.6	1224	26793	131.3	20.1	310
0.250	9.4	1095	28198	143.7	9.6	162
0.000	8.5	986	29824	151.9	0.0	0

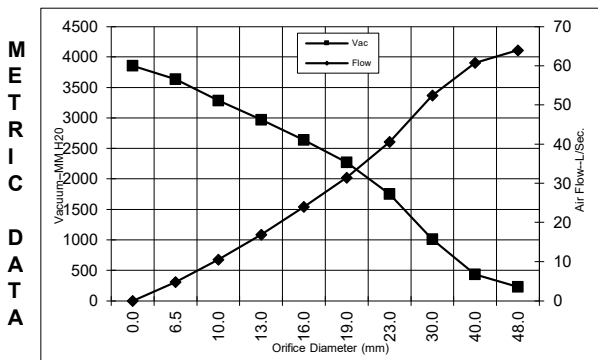

Orifice (mm)	Amps	Watts (In)	RPM	Vac (mm H2O)	Flow (L/Sec)	Air Watts
48.0	15.1	1702	23000	228	64.0	142
40.0	15.1	1709	22938	435	60.7	257
30.0	15.2	1723	22838	1012	52.4	516
23.0	14.9	1683	23089	1750	40.6	690
19.0	14.2	1615	23480	2271	31.4	698
16.0	13.4	1526	24199	2638	24.0	618
13.0	12.2	1394	25183	2971	16.8	488
10.0	10.8	1247	26567	3286	10.5	334
6.5	9.5	1101	28127	3635	4.8	170
0.0	8.5	986	29824	3857	0.0	0

Note: Metric Performance data is calculated from the ASTM data above.

* Data represents performance of a typical motor sampled from a large production quantity. Individual motor data may vary due to normal manufacturing variations.

Test Specs:	120-Volts	Minimum Sealed Vacuum:	146.0	ORIFICE:	7/8"	Min. Vacuum:	64.0	Maximum Watts:	1840
--------------------	-----------	-------------------------------	-------	-----------------	------	---------------------	------	-----------------------	------

NOTES:

1. LEADS: 16GA. STRANDED, BLACK.
2. MOTOR IDENTIFICATION: MANUFACTURER'S NAME, MODEL NUMBER, VOLTAGE, FREQUENCY, INSPECTOR'S CODE WITH "FF" SUFFIX, DATE OF MANUFACTURE, AGENCY RECOGNITION CODE, PLANT LOCATION CODE, PATENT PENDING AND COUNTRY OF ORIGIN.
3. MOUNTING MUST NOT RESTRICT THIS DIAMETER.
4. ALLOW [0.0026 SQ M]/4.0 SQ IN. (MIN.) FOR COOLING AIR INTAKE.
5. COOLING AIR INTAKE MUST BE SEPARATED FROM COOLING AIR EXHAUST.
6. COOLING AIR EXHAUST MUST BE SEPARATED FROM VACUUM EXHAUST.

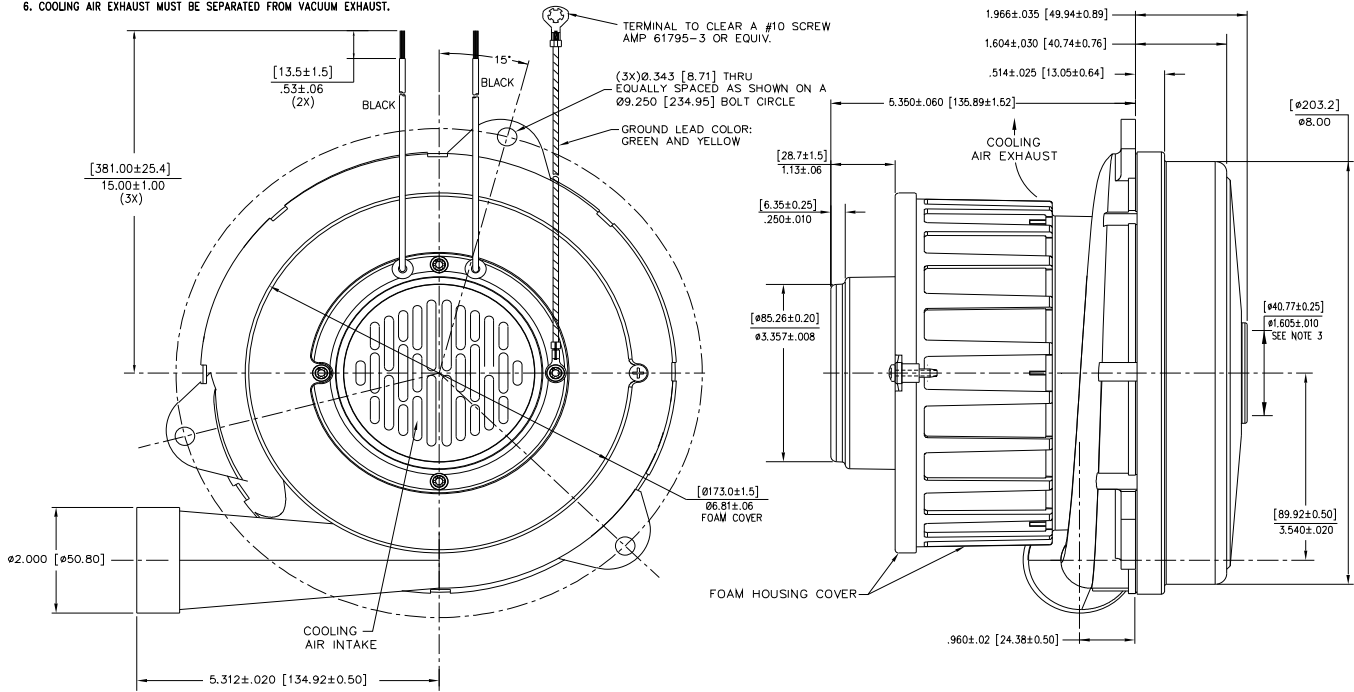

IMPORTANT NOTE: Pictorial and dimensional data are subject to change without notice. Contact factory for current revision levels.

Warning: When using Lamb Vacuum Bypass Motors by Bison (formerly AMETEK DFS) in machines that come in contact with foam, liquid (including water), or other foreign substances, the machine must be designed and constructed to prevent those substances from reaching the fan system, motor housing, and electrical components. Lamb Vacuum Motors other than hazardous duty models should not be applied in machines that come in contact with dry chemicals or other volatile materials. Failure to observe these precautions could cause flashing (depending on volatility) or electrical shock which could result in property damage and severe bodily injury, including death in extreme cases. All applications incorporating Lamb Vacuum Motors should be submitted to appropriate organizations or agencies for testing specifically related to the safety of your equipment.

Bison® | Lamb® | Nautilair® | Prestolite Motors | ROTRON® | Windjammer®

Bison®: 100 East Erie St., Suite 200; Kent, OH 44240 BisonAMETEK.com