



AMETEK

Lamb Electric

Product Bulletin

Model: 122341-00

Configuration

- One-stage
- 120 volts AC
- 5.7" / 145 mm diameter
- Ball / Ball bearings
- One-speed
- ThruFlow Design
- Aluminum fan end bracket
- Aluminum commutator bracket

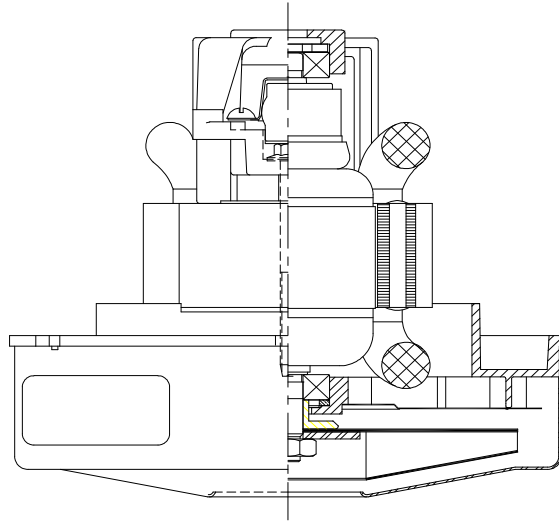

Features

- Suitable for 120 volt AC operation, 50/60 Hz
- UL recognized, category PRGY2 (E47185)
- Provision for grounding
- Skeleton frame design
- Tapered fan system
- AutoReset Thermostat

The Lamb vacuum motor line offers a wide range of performance levels to meet design needs

TYPICAL MOTOR PERFORMANCE.*

(At 120 volts, 60Hz, test data is corrected to standard conditions of 29.92 Hg, 68° F.)

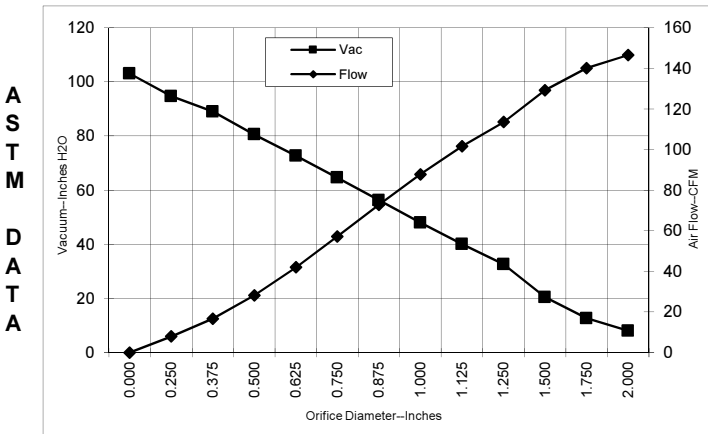

Orifice (Inches)	Amps	Watts (In)	RPM	Vac (In.H2O)	Flow (CFM)	Air Watts
2.000	11.4	1332	27398	8.0	146.5	138
1.750	11.6	1351	27174	12.7	140.1	208
1.500	11.8	1378	26896	20.4	129.2	310
1.250	11.9	1387	26764	32.6	113.6	435
1.125	11.7	1367	27009	40.0	101.6	478
1.000	11.4	1328	27417	48.0	87.8	494
0.875	10.9	1281	28038	56.3	72.8	481
0.750	10.4	1213	28936	64.6	57.2	434
0.625	9.6	1132	30188	72.7	42.0	359
0.500	8.8	1040	31774	80.5	28.2	267
0.375	8.2	965	33587	89.0	16.7	175
0.250	7.4	883	35323	94.7	8.0	89
0.000	7.1	846	36603	103.0	0.0	0

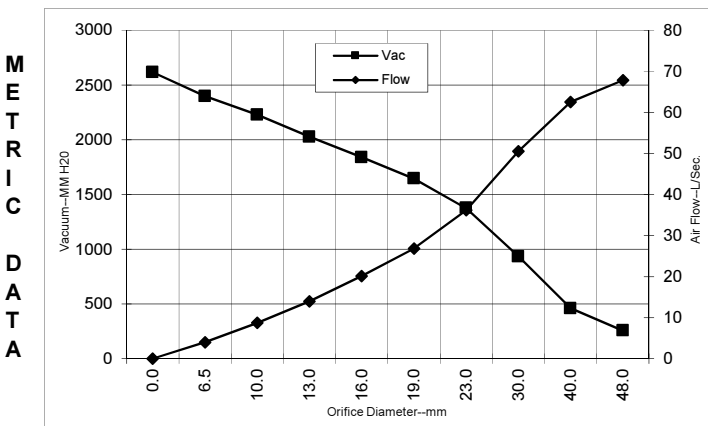

Orifice (mm)	Amps	Watts (In)	RPM	Vac (mm H2O)	Flow (L/Sec)	Air Watts
48.0	11.5	1340	27299	256	67.8	169
40.0	11.7	1370	26980	460	62.5	279
30.0	11.8	1376	26898	933	50.5	459
23.0	11.0	1293	27882	1376	36.1	484
19.0	10.3	1211	28961	1645	26.9	432
16.0	9.7	1135	30138	1839	20.1	362
13.0	8.9	1049	31616	2026	14.0	276
10.0	8.3	977	33315	2228	8.7	189
6.5	7.5	887	35237	2398	4.0	93
0.0	7.1	846	36603	2616	0.0	0

Note: Metric performance data is calculated from the ASTM data above.

*** PLEASE NOTE: Data represents performance of a development motor from engineering tests. Final published Product Bulletin will use typical performance of samples from a large manufacturing quantity.**

Test Specs:	120 volts	Minimum Sealed Vacuum: 95"	ORIFICE:	7/8 "	Minimum Vacuum: 51"	Maximum Watts: 1400
-------------	-----------	----------------------------	----------	-------	---------------------	---------------------

DIMENSIONS

NOTES: UNLESS OTHERWISE SPECIFIED.

1. LEADS: 18GA. STRANDED. LEADS CAN BE ANY COLOR EXCEPT GREEN OR GREEN WITH YELLOW STRIPE.
2. GROUNDING OR EARTHING PROVISIONS: USE HOLES AS INDICATED FOR GROUNDING OR EARTHING. REFER TO APPROPRIATE LISTING OR REGULATORY AGENCY FOR PROPER METHOD OF GROUNDING OR EARTHING.
3. MOTOR IDENTIFICATION: MANUFACTURER'S NAME, MODEL NUMBER, VOLTAGE, FREQUENCY, INSPECTORS CODE, DATE OF MANUFACTURE, AGENCY RECOGNITION CODE, PLANT LOCATION CODE AND COUNTRY OF ORIGIN.

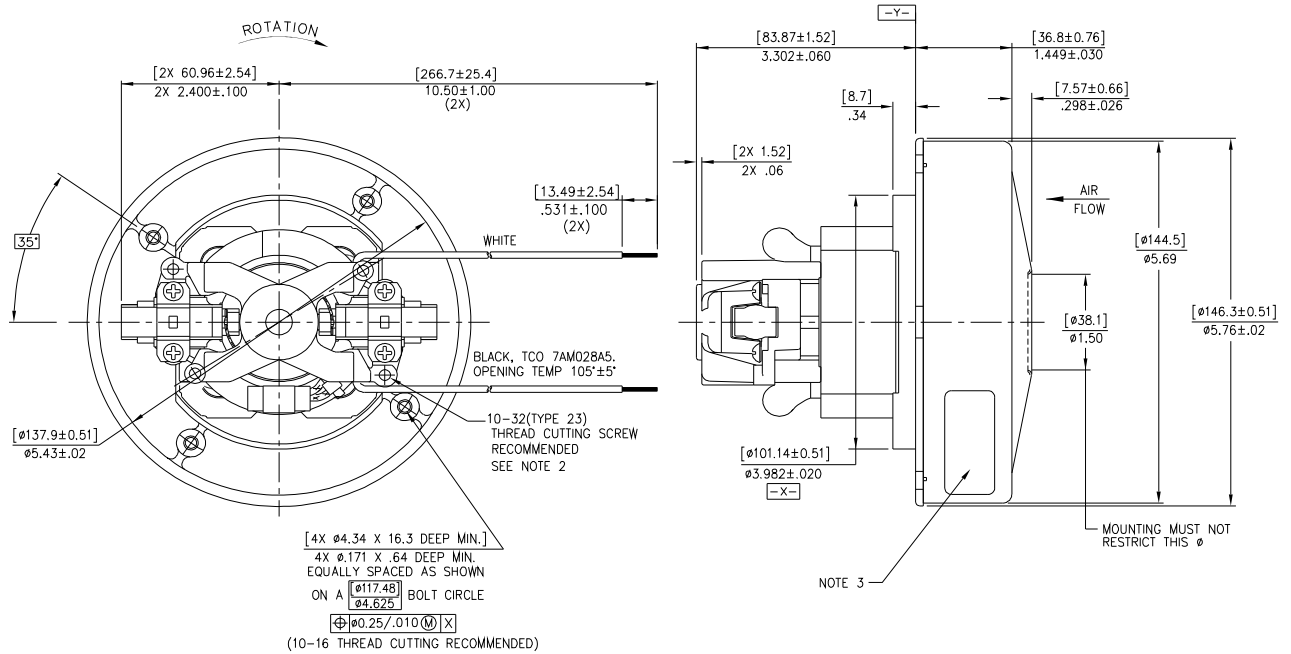

WARNING - When using AMETEK Floorcare & Specialty Motors (F&SM) bypass motors in machines that come in contact with foam, liquid (including water), or other foreign substances, the machine must be designed and constructed to prevent those substances from reaching the fan system, motor housing, and electrical components. F&SM vacuum motors other than hazardous duty models should not be applied in machines that come in contact with dry chemicals or other volatile materials. Failure to observe these precautions could cause flashing (depending on volatility) or electrical shock which could result in property damage and severe bodily injury, including death in extreme cases. All applications incorporating F&SM motors should be submitted to appropriate organizations or agencies for testing specifically related to the safety of your equipment.

AMETEK Dynamic Fluid Solutions
www.ametekdfs.com