

DESCRIPTION

- Two stage
- 230 volts
- 5.7"/145 mm diameter
- Double ball bearings
- Single speed
- Thru-flow discharge
- Steel End bracket
- Thermoset Commutator bracket

DESIGN APPLICATION

- Equipment operating in environments not requiring separation of working air from motor ventilating air
- Designed to handle clean, dry, filtered air only

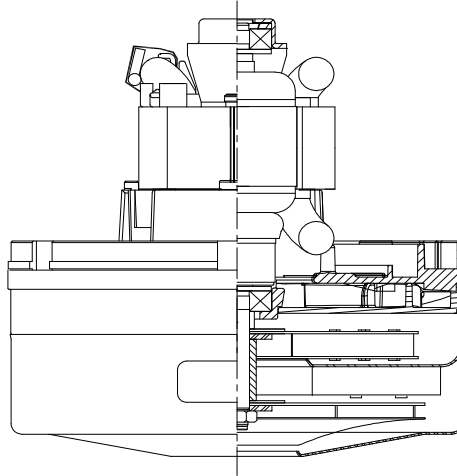

SPECIAL FEATURES

- Suitable for 230 volt AC operation, 50/60 Hz
- UL recognized, category PRGY2 (E47185)
- Provision for grounding
- Skeleton-frame construction
- High Efficient fan system
- Auto-Reset Thermal Device
- Patented "Eternity" brush mech for 2000+ hours life
- The Lamb Electric vacuum motor line offers a wide range of performance levels to meet design needs
- Features quick connect brushes

TYPICAL MOTOR PERFORMANCE.*

(At 230 volts, 60Hz, test data is corrected to standard conditions of 29.92 Hg, 68° F.)

ASTM DATA

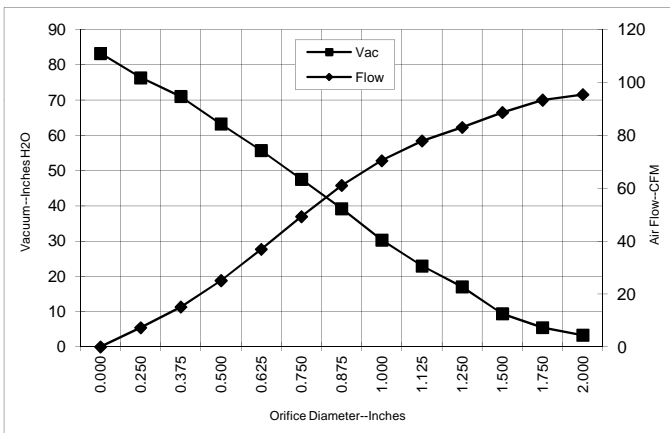

Orifice (Inches)	Amps	Watts (In)	RPM	Vac (In.H2O)	Flow (CFM)	Air Watts
2.000	3.3	701	18,726	3.3	95.4	37
1.750	3.3	704	18,671	5.5	93.3	60
1.500	3.3	710	18,610	9.4	88.7	98
1.250	3.4	716	18,493	17.0	83.0	166
1.125	3.4	719	18,420	23.0	77.9	210
1.000	3.4	722	18,352	30.3	70.4	250
0.875	3.4	716	18,395	39.2	61.1	281
0.750	3.2	694	18,702	47.6	49.3	275
0.625	3.1	658	19,234	55.7	36.9	241
0.500	2.8	611	20,024	63.2	25.1	186
0.375	2.6	559	20,980	71.0	15.1	126
0.250	2.4	518	21,880	76.3	7.3	65
0.000	2.2	483	22,670	83.2	0.0	0

METRIC DATA

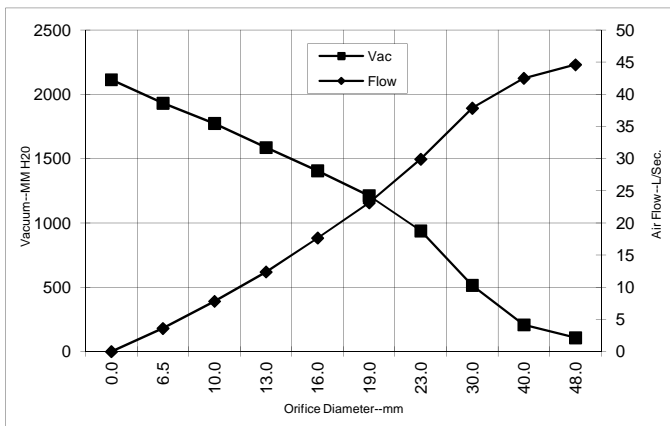

Orifice (mm)	Amps	Watts (In)	RPM	Vac (mm H2O)	Flow (L/Sec)	Air Watts
48.0	3.3	702	18702	108	44.6	47
40.0	3.3	708	18628	209	42.5	86
30.0	3.4	717	18453	515	37.9	190
23.0	3.4	717	18385	939	29.9	273
19.0	3.2	693	18712	1212	23.1	274
16.0	3.1	659	19213	1406	17.7	243
13.0	2.9	616	19945	1587	12.4	192
10.0	2.6	567	20836	1775	7.8	135
6.5	2.4	520	21835	1932	3.6	68
0.0	2.2	483	22670	2114	0.0	0

Note: Metric Performance data is calculated from the ASTM data above.

* Data represents performance of a typical motor sampled from a large production quantity. Individual motor data may vary due to normal manufacturing variations.

Test Specs: 230 volts	Minimum Sealed Vacuum: 74"	ORIFICE: 7/8 "	Minimum Vacuum: 35"	Maximum Watts: 754
------------------------------	-----------------------------------	-----------------------	----------------------------	---------------------------

DIMENSIONS

NOTES:

1. MODEL NUMBER, DATE OF MANUFACTURE, PLANT LOCATION CODE, AGENCY RECOGNITION CODE, INSPECTOR'S CODE, MANUFACTURER'S NAME, VOLTAGE AND FREQUENCY, AND CUSTOMER'S PART NO. TO APPEAR ON MOTOR.
2. MOUNTING MUST NOT RESTRICT THIS DIAMETER.
3. GROUND LEAD: 18GA STRANDED, GREEN OR GREEN WITH YELLOW STRIPES..
4. GROUNDING OR EARTHING PROVISIONS: USE HOLES AS INDICATED FOR GROUNDING OR EARTHING. REFER TO APPROPRIATE LISTING OR REGULATORY AGENCY FOR PROPER METHOD OF GROUNDING OR EARTHING.

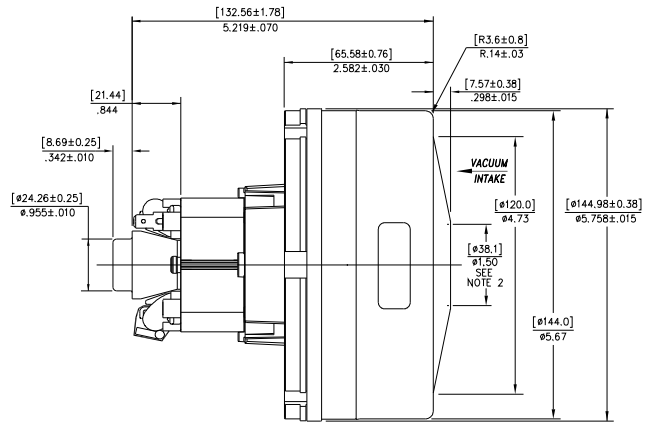
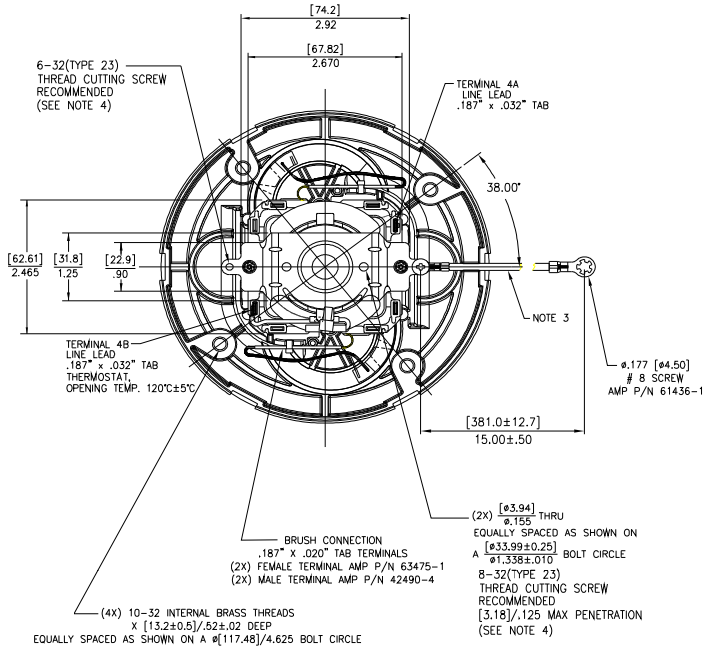

IMPORTANT NOTE: Pictorial and dimensional data are subject to change without notice. Contact factory for current revision levels.

WARNING - When using AMETEK Floorcare & Specialty Motors (F&SM) bypass motors in machines that come in contact with foam, liquid (including water), or other foreign substances, the machine must be designed and constructed to prevent those substances from reaching the fan system, motor housing, and electrical components. F&SM vacuum motors other than hazardous duty models should not be applied in machines that come in contact with dry chemicals or other volatile materials. Failure to observe these precautions could cause flashing (depending on volatility) or electrical shock which could result in property damage and severe bodily injury, including death in extreme cases. All applications incorporating F&SM motors should be submitted to appropriate organizations or agencies for testing specifically related to the safety of your equipment.

AMETEK/Floorcare & Specialty Motors
www.ametekfsm.com