



Floorcare & Specialty Motors

Model: 122288-00

Advantek III - Ultra

DESCRIPTION

- Two stage
- 120 volts
- 5.7"/145 mm diameter
- Double ball bearings
- Single speed
- Thru-flow discharge
- Thermoset fan end bracket
- Stamped steel top end bracket
- Thermostat equipped

DESIGN APPLICATION

- Equipment operating in environments not requiring separation of working air from motor ventilating air
- Designed to handle clean, dry, filtered air only

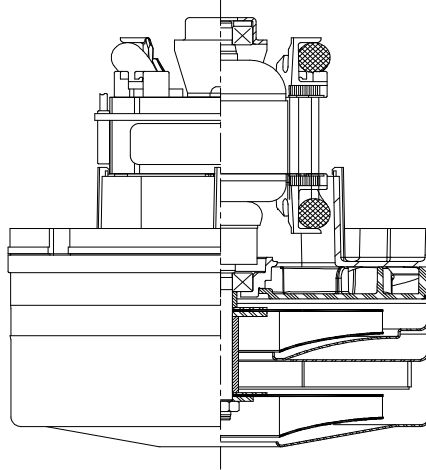

SPECIAL FEATURES

- Suitable for 120 volt AC operation, 60 Hz
- UL recognized, category PRGY2 (E47185)
- Provision for grounding
- Skeleton-frame construction
- High efficiency fan system
- The Lamb Electric vacuum motor line offers a wide range of performance levels to meet design needs
- The -08 version has leads attached.

PEAK AIRWATTS
600
Calculated in accordance with ASTM F2105

TYPICAL MOTOR PERFORMANCE.*

(At 120 volts, 60Hz, test data is corrected to standard conditions of 29.92 Hg, 68° F.)

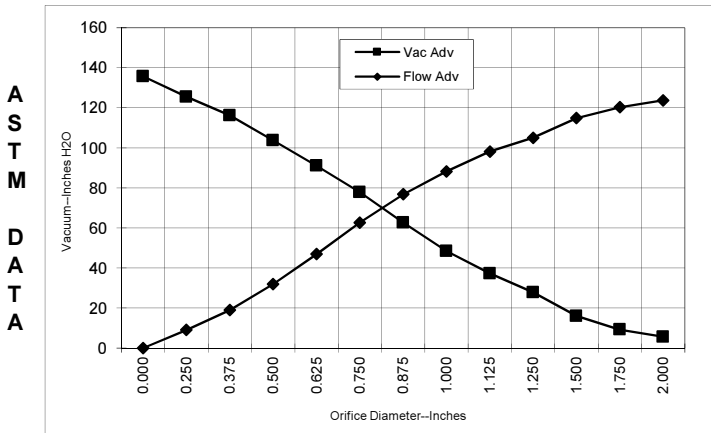

| Orifice (Inches) | Amps | Watts (In) | RPM | Vac (In.H2O) | Flow (CFM) | Air Watts |
|------------------|------|------------|-------|--------------|------------|-----------|
| 2.000 | 13.2 | 1529 | 23075 | 6.2 | 129.5 | 95 |
| 1.750 | 13.2 | 1526 | 23071 | 10.1 | 125.5 | 149 |
| 1.500 | 13.1 | 1519 | 23106 | 17.1 | 118.5 | 237 |
| 1.250 | 13.0 | 1506 | 23229 | 29.5 | 108.2 | 375 |
| 1.125 | 12.9 | 1495 | 23336 | 38.9 | 100.3 | 458 |
| 1.000 | 12.7 | 1477 | 23444 | 51.3 | 90.6 | 546 |
| 0.875 | 12.4 | 1437 | 23755 | 64.8 | 78.1 | 593 |
| 0.750 | 11.8 | 1368 | 24399 | 77.1 | 62.3 | 564 |
| 0.625 | 10.9 | 1273 | 25375 | 89.9 | 46.6 | 491 |
| 0.500 | 9.9 | 1164 | 26704 | 101.5 | 31.6 | 377 |
| 0.375 | 8.9 | 1047 | 28384 | 112.8 | 18.7 | 248 |
| 0.250 | 8.1 | 955 | 29924 | 122.8 | 9.0 | 129 |
| 0.000 | 7.4 | 875 | 31622 | 132.6 | 0.0 | 0 |

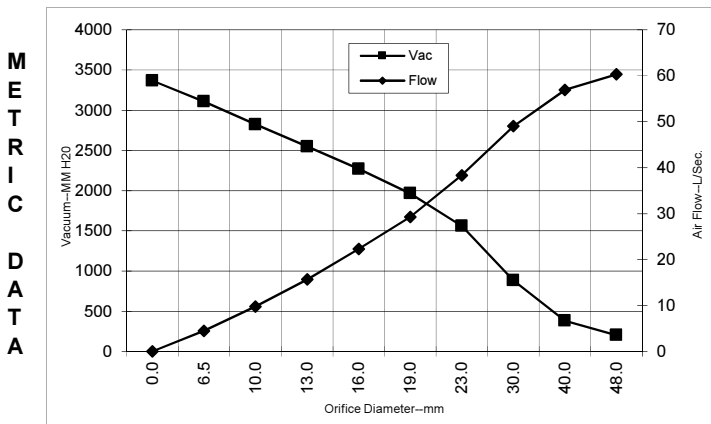

| Orifice (mm) | Amps | Watts (In) | RPM | Vac (mm H2O) | Flow (L/Sec) | Air Watts |
|--------------|------|------------|-------|--------------|--------------|-----------|
| 48.0 | 13.2 | 1527 | 23073 | 201 | 60.3 | 118 |
| 40.0 | 13.1 | 1521 | 23096 | 380 | 56.9 | 211 |
| 30.0 | 13.0 | 1500 | 23288 | 881 | 49.0 | 421 |
| 23.0 | 12.5 | 1447 | 23677 | 1560 | 38.3 | 582 |
| 19.0 | 11.7 | 1366 | 24419 | 1964 | 29.3 | 562 |
| 16.0 | 10.9 | 1277 | 25336 | 2269 | 22.3 | 494 |
| 13.0 | 10.0 | 1175 | 26571 | 2549 | 15.6 | 388 |
| 10.0 | 9.0 | 1065 | 28132 | 2822 | 9.7 | 267 |
| 6.5 | 8.1 | 959 | 29847 | 3107 | 4.5 | 135 |
| 0.0 | 7.4 | 875 | 31622 | 3367 | 0.0 | 0 |

Note: Metric Performance data is calculated from the ASTM data above.

* Data represents performance of a typical motor sampled from a large production quantity. Individual motor data may vary due to normal manufacturing variations.

| | | | | | | | |
|-------------|-----------|-----------------------------|----------|-------|---------------------|----------------|------|
| Test Specs: | 120 volts | Minimum Sealed Vacuum: 120" | ORIFICE: | 7/8 " | Minimum Vacuum: 60" | Maximum Watts: | 1480 |
|-------------|-----------|-----------------------------|----------|-------|---------------------|----------------|------|

DIMENSIONS

NOTES:

1. MODEL NUMBER, DATE OF MANUFACTURE, PLANT LOCATION CODE, AGENCY RECOGNITION CODE, INSPECTOR'S CODE, MANUFACTURER'S NAME, "US PATENT: US 6,703,754 B1", VOLTAGE AND FREQUENCY, AND CUSTOMER'S PART NO. TO APPEAR ON MOTOR.
2. MOUNTING MUST NOT RESTRICT THIS DIAMETER.
3. GROUNDING OR EARTHING PROVISIONS: USE HOLES AS INDICATED FOR GROUNDING OR EARTHING. REFER TO APPROPRIATE LISTING OR REGULATORY AGENCY FOR PROPER METHOD OF GROUNDING OR EARTHING.

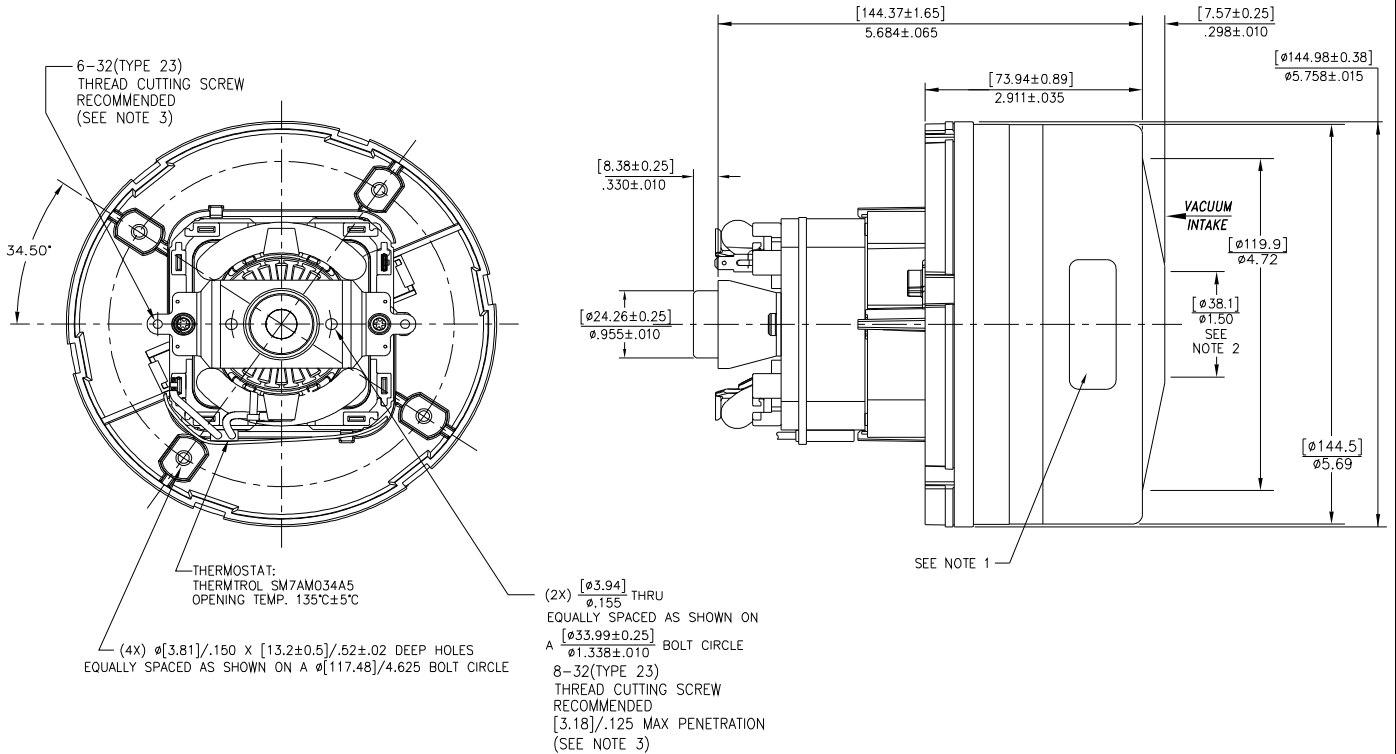

IMPORTANT NOTE: Pictorial and dimensional data are subject to change without notice. Contact factory for current revision levels.

WARNING - When using AMETEK Floorcare & Specialty Motors (F&SM) bypass motors in machines that come in contact with foam, liquid (including water), or other foreign substances, the machine must be designed and constructed to prevent those substances from reaching the fan system, motor housing, and electrical components. F&SM vacuum motors other than hazardous duty models should not be applied in machines that come in contact with dry chemicals or other volatile materials. Failure to observe these precautions could cause flashing (depending on volatility) or electrical shock which could result in property damage and severe bodily injury, including death in extreme cases. All applications incorporating F&SM motors should be submitted to appropriate organizations or agencies for testing specifically related to the safety of your equipment.

AMETEK/Floorcare & Specialty Motors
www.ametekfsm.com