

# AMETEK

## Floorcare & Specialty Motors

## Product Bulletin

Model: 122286-41

### Advantek III - Ultra II



#### DESCRIPTION

- Two stage
- 230 volts
- 5.7"/145 mm diameter
- Double ball bearings
- Single speed
- Thru-flow discharge
- Thermoset fan end bracket
- Stamped steel end bracket

#### DESIGN APPLICATION

- Equipment operating in environments not requiring separation of working air from motor ventilating air
- Designed to handle clean, dry, filtered air only

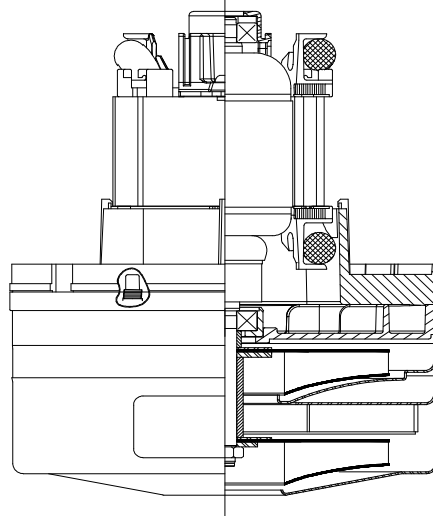

#### SPECIAL FEATURES

- **650 Peak Air Watts**
- Patented Advantek II diffusion
- 3" Commercial Lamination
- Dual Tapered fan system
- Provision for grounding
- Top end mounting boss
- Thermal Device
- UL recognized, category PRGY2 (E47185)
- Suitable for 230 volt AC operation, 50 or 60 Hz
- The Lamb vacuum motor line offers a wide range of performance levels to meet design needs

**PEAK AIRWATTS**  
**650**

Calculated in accordance with ASTM F2105

#### TYPICAL MOTOR PERFORMANCE.\*

(At 230 volts, 60Hz, test data is corrected to standard conditions of 29.92 Hg, 68° F.)

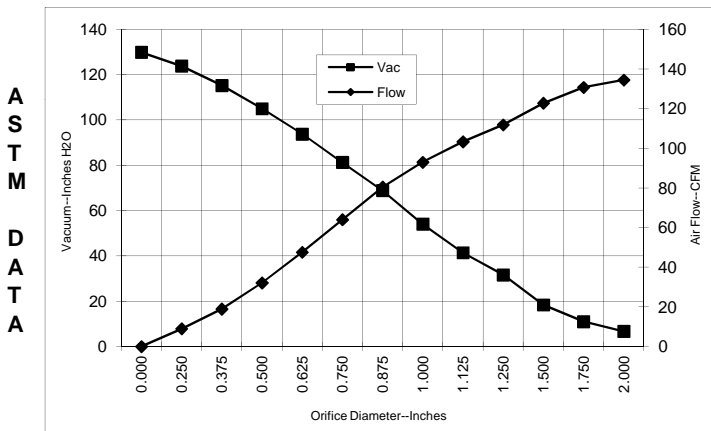

Orifice (Inches)	Amps	Watts (In)	RPM	Vac (In.H <sub>2</sub> O)	Flow (CFM)	Air Watts
2.000	7.1	1595	24544	6.7	134.4	106
1.750	7.1	1590	24685	11.0	130.7	168
1.500	7.1	1585	24735	18.4	122.8	265
1.250	7.0	1567	24923	31.6	111.8	415
1.125	7.0	1553	24967	41.4	103.3	502
1.000	6.9	1543	25086	54.0	92.9	589
0.875	6.7	1491	26355	68.9	80.4	650
0.750	6.3	1427	25932	81.3	64.0	610
0.625	5.8	1317	26792	93.8	47.6	523
0.500	5.3	1195	27753	104.9	32.1	396
0.375	4.7	1065	29337	115.2	18.9	256
0.250	4.0	924	30678	123.8	9.0	130
0.000	3.7	844	32127	129.8	0.0	0

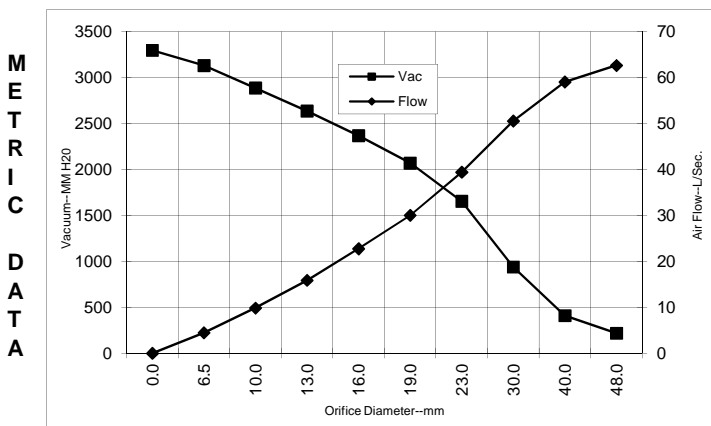

Orifice (mm)	Amps	Watts (In)	RPM	Vac (mm H <sub>2</sub> O)	Flow (L/Sec)	Air Watts
48.0	7.1	1593	24606	218	62.7	134
40.0	7.1	1587	24720	410	59.1	236
30.0	7.0	1548	24947	940	50.6	463
23.0	6.7	1443	26038	1655	39.4	635
19.0	6.3	1315	25949	2070	30.0	608
16.0	5.9	1200	26758	2369	22.8	527
13.0	5.3	1078	27657	2637	15.9	408
10.0	4.8	945	29099	2888	9.9	277
6.5	4.1	848	30611	3133	4.5	137
0.0	3.7	844	32127	3298	0.0	0

Note: Metric Performance data is calculated from the ASTM data above.

\* Data represents performance of a typical motor sampled from a large production quantity. Individual motor data may vary due to normal manufacturing variations.

Test Specs:	230	Minimum Sealed Vacuum:	123.0	ORIFICE:	7/8 "	Minimum Vacuum:	58.0	Maximum Watts:	1475
-------------	-----	------------------------	-------	----------	-------	-----------------	------	----------------	------



**DIMENSIONS**

**NOTES:**

1. MODEL NUMBER, DATE OF MANUFACTURE, PLANT LOCATION CODE, AGENCY RECOGNITION CODE, INSPECTOR'S CODE, MANUFACTURER'S NAME, "US PATENT: US 6,703,754 B1", VOLTAGE AND FREQUENCY, "08B ARM, 02F FLD" TO APPEAR ON MOTOR.
2. MOUNTING MUST NOT RESTRICT THIS DIAMETER.
3. GROUNDING OR EARTHING PROVISIONS: USE HOLES AS INDICATED FOR GROUNDING OR EARTHING. REFER TO APPROPRIATE LISTING OR REGULATORY AGENCY FOR PROPER METHOD OF GROUNDING OR EARTHING.
4. LEADS 18 GA. STRANDED.

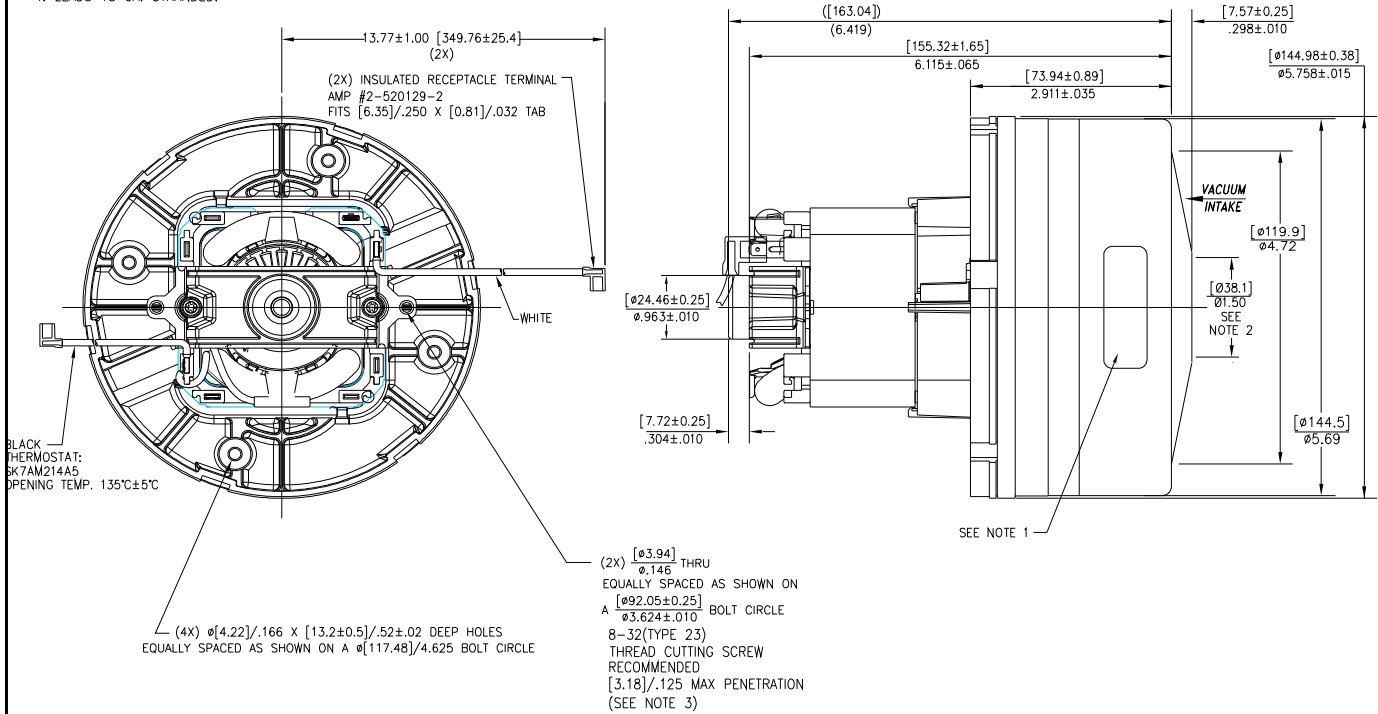

**Advantek III - Ultra II**

**IMPORTANT NOTE:** Pictorial and dimensional data are subject to change without notice. Contact factory for current revision levels.

**WARNING** - When using AMETEK Floorcare & Specialty Motors (F&SM) bypass motors in machines that come in contact with foam, liquid (including water), or other foreign substances, the machine must be designed and constructed to prevent those substances from reaching the fan system, motor housing, and electrical components. F&SM vacuum motors other than hazardous duty models should not be applied in machines that come in contact with dry chemicals or other volatile materials. Failure to observe these precautions could cause flashing (depending on volatility) or electrical shock which could result in property damage and severe bodily injury, including death in extreme cases. All applications incorporating F&SM motors should be submitted to appropriate organizations or agencies for testing specifically related to the safety of your equipment.

**AMETEK/Floorcare & Specialty Motors**  
[www.ametekfsm.com](http://www.ametekfsm.com)