



**Floorcare & Specialty Motors**

**Model: 122238-18**

**SPECIAL FEATURES**

- 2000+ hours life
- 220 Peak Air Watts
- Up to 36% Overall Efficiency
- High efficient cooling system
- Lamb "Green Power Label"
- UL recognized, category PRGY2 (E47185)
- CSA certification pending
- New patent-pending bearing protection for wet applications.

**DESCRIPTION**

- 36 volts DC
- Two-stage tapered fan
- 6.6" / 162 mm diameter
- Improved sound quality
- "True" tangential discharge bracket
- High-Efficiency "Galaxy" lamination
- Double ball bearings; 10mm output

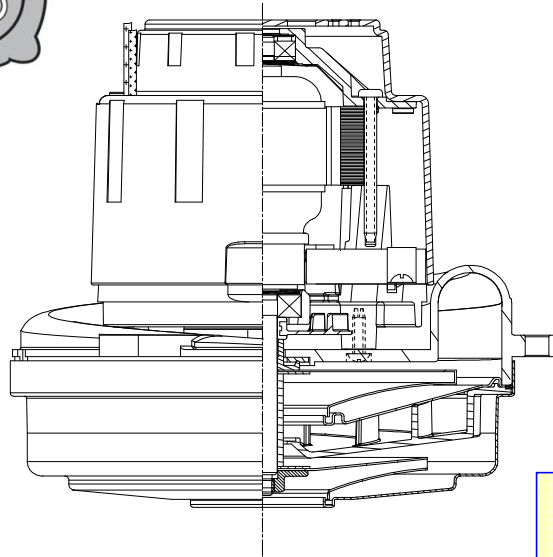

**DESIGN APPLICATION**

- Equipment operating in environments requiring separation of working air from motor ventilating air
- Designed to handle clean, dry, filtered air only

**PEAK AIRWATTS**

**227**

Calculated in accordance with ASTM F2105

**TYPICAL MOTOR PERFORMANCE.\***

(At 36 volts DC, test data is corrected to standard conditions of 29.92 Hg, 68° F.)

**ASTM DATA**

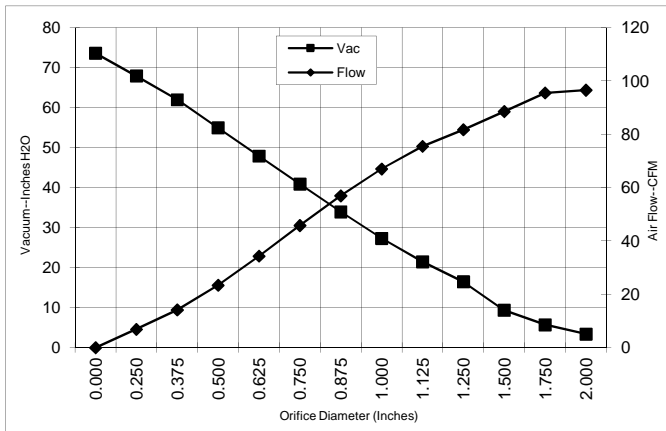

Orifice (Inches)	Amps	Watts (In)	RPM	Vac (In.H2O)	Flow (CFM)	Air Watts
2.000	18.0	650	16025	3.4	96.6	39
1.750	18.1	651	16019	5.7	95.5	64
1.500	18.1	652	16010	9.4	88.5	97
1.250	18.2	655	15940	16.5	81.7	158
1.125	18.3	659	15883	21.5	75.5	190
1.000	18.3	660	15861	27.3	67.0	215
0.875	18.2	656	15958	34.0	57.0	227
0.750	17.7	639	16227	40.9	45.8	220
0.625	16.9	610	16763	47.9	34.3	193
0.500	15.8	571	17601	54.9	23.4	151
0.375	14.4	522	18688	62.0	14.2	103
0.250	13.4	486	19695	67.9	6.9	55
0.000	12.4	451	20624	73.6	0.0	0

**METRIC DATA**

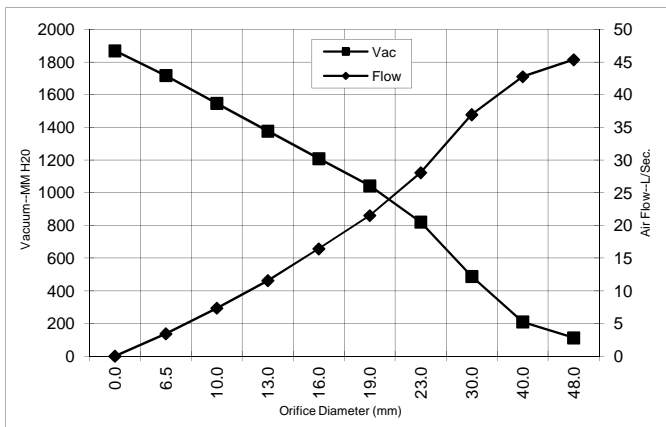

Orifice (mm)	Amps	Watts (In)	RPM	Vac (mm H2O)	Flow (L/Sec)	Air Watts
48.0	18.0	651	16023	112	45.4	50
40.0	18.1	652	16012	210	42.8	87
30.0	18.2	657	15909	489	37.0	176
23.0	18.2	657	15934	821	28.1	224
19.0	17.7	639	16237	1043	21.5	219
16.0	16.9	611	16741	1210	16.4	194
13.0	15.9	575	17517	1378	11.6	155
10.0	14.6	529	18525	1547	7.3	110
6.5	13.5	488	19644	1718	3.4	57
0.0	12.4	451	20624	1869	0.0	0

Note: Metric Performance data is calculated from the ASTM data above.

\* Data represents performance of a typical motor sampled from a large production quantity. Individual motor data may vary due to normal manufacturing variations.

<b>Test Specs:</b>	<b>36 VDC</b>	<b>Minimum Sealed Vacuum:</b>	<b>65.0</b>	<b>ORIFICE:</b>	<b>7/8"</b>	<b>Min. Vacuum:</b>	<b>31.5</b>	<b>Maximum Watts:</b>	<b>710</b>
--------------------	---------------	-------------------------------	-------------	-----------------	-------------	---------------------	-------------	-----------------------	------------

**DIMENSIONS**

**NOTES:**

1. LEADS: 16GA. STRANDED, POWER LEADS BLACK AND WHITE. GROUNDING LEAD GREEN OR GREEN WITH YELLOW STRIPE.
2. MOTOR IDENTIFICATION: MANUFACTURER'S NAME, MODEL NUMBER, VOLTAGE, FREQUENCY, INSPECTOR'S CODE WITH "FF" SUFFIX, DATE OF MANUFACTURE, AGENCY RECOGNITION CODE, PLANT LOCATION CODE, PATENT PENDING\* AND COUNTRY OF ORIGIN.
3. MOUNTING MUST NOT RESTRICT THIS DIAMETER.
4. ALLOW [0.0026 SQ M]/4.0 SQ IN. (MIN.) FOR COOLING AIR INTAKE.
5. COOLING AIR INTAKE MUST BE SEPARATED FROM COOLING AIR EXHAUST.
6. COOLING AIR EXHAUST MUST BE SEPARATED FROM VACUUM EXHAUST.

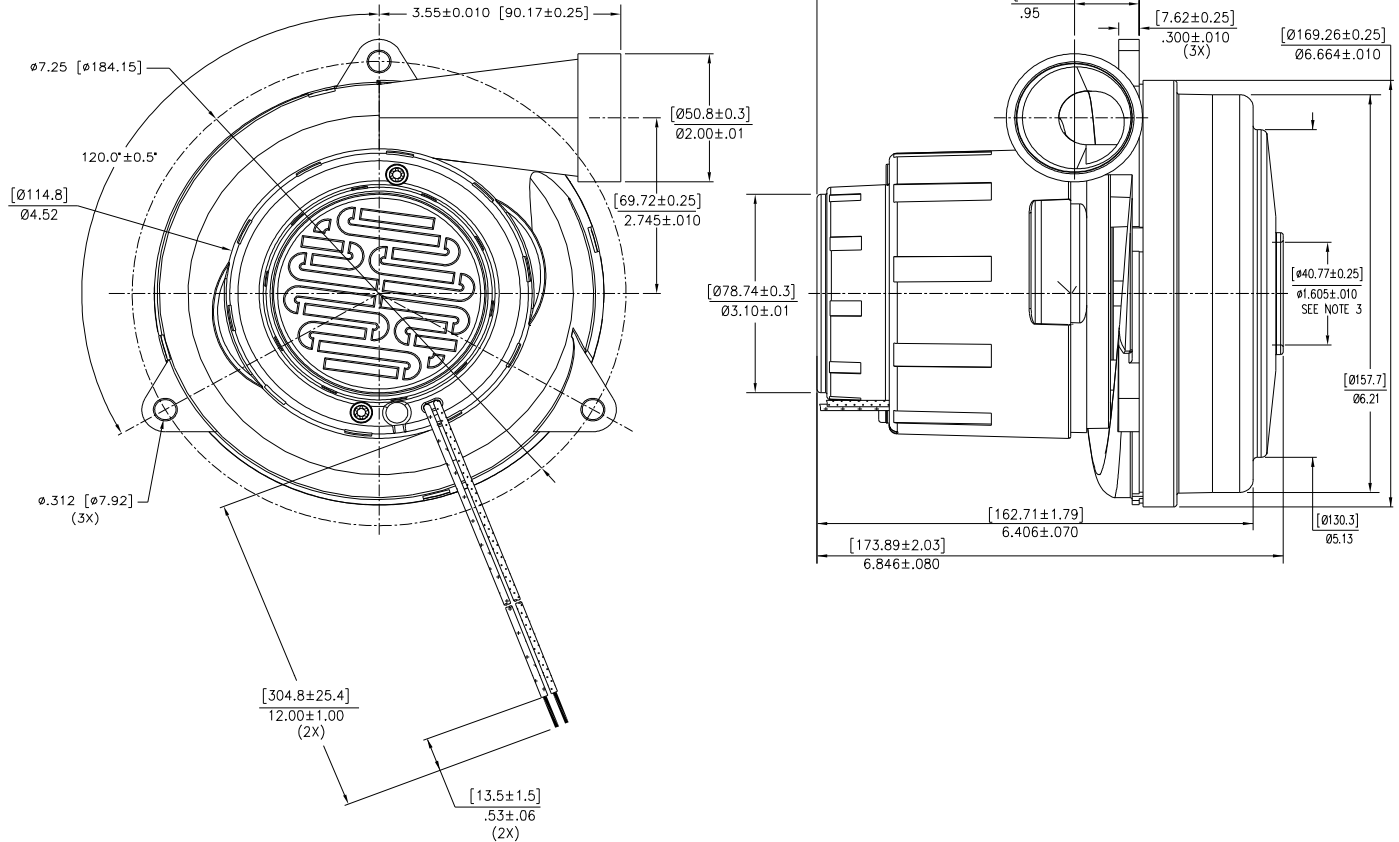

**IMPORTANT NOTE:** Pictorial and dimensional data are subject to change without notice. Contact factory for current revision levels.

**WARNING** - When using AMETEK Floorcare & Specialty Motors (F&SM) bypass motors in machines that come in contact with foam, liquid (including water), or other foreign substances, the machine must be designed and constructed to prevent those substances from reaching the fan system, motor housing, and electrical components. F&SM vacuum motors other than hazardous duty models should not be applied in machines that come in contact with dry chemicals or other volatile materials. Failure to observe these precautions could cause flashing (depending on volatility) or electrical shock which could result in property damage and severe bodily injury, including death in extreme cases. All applications incorporating F&SM motors should be submitted to appropriate organizations or agencies for testing specifically related to the safety of your equipment.

**AMETEK/Floorcare & Specialty Motors**  
**www.ametekfsm.com**

Issued: June, 2010