



Lamb Electric

Model: 122236-17

SPECIAL FEATURES

- 1500+ hours life (curved brush)
- 646 Peak Air Watts
- Up to 41% Overall Efficiency
- High efficient cooling system
- Thermally Protected.
- RU recognized, category XERW2/8 (E27701)
- Locked-rotor, blocked cooling air.
- Class B Insulation

DESCRIPTION

- 230 volts AC
- Two-stage tapered fan
- 6.6" / 162 mm diameter
- Improved sound quality
- "True" tangential discharge bracket
- High-Efficiency "Galaxy" lamination
- Double ball bearings; 10mm output

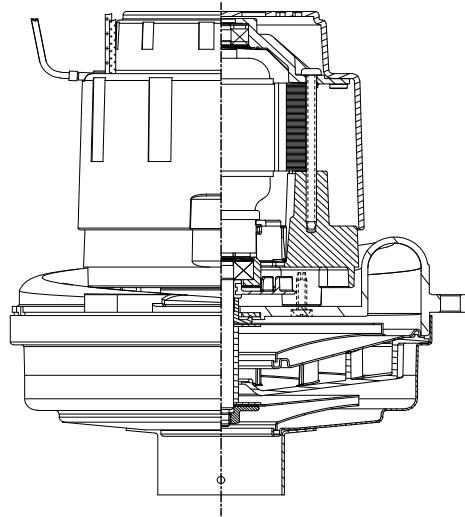

DESIGN APPLICATION

- Commercial and Residential Central Cleaning Systems
- Car wash vac and blower systems
- Equipment operating in environments requiring separation of working air from motor ventilating air
- Designed to handle clean, dry, filtered air only

PEAK AIRWATTS
646
Calculated in accordance with ASTM F2105

TYPICAL MOTOR PERFORMANCE.*

(At 230 volts, 60Hz, test data is corrected to standard conditions of 29.92 Hg, 68° F.)

ASTM DATA

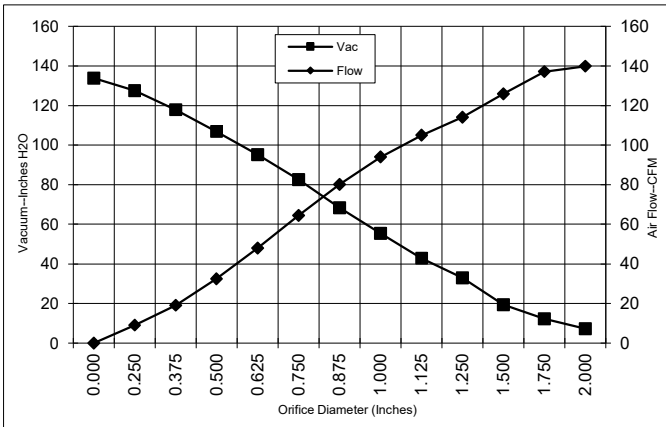

Orifice (Inches)	Amps	Watts (In)	RPM	Vac (In.H2O)	Flow (CFM)	Air Watts
2.000	7.4	1614	23255	7.3	139.9	120
1.750	7.4	1608	23303	12.2	137.2	196
1.500	7.4	1607	23304	19.4	126.0	286
1.250	7.3	1596	23399	32.9	114.0	441
1.125	7.2	1584	23400	42.8	105.0	528
1.000	7.3	1592	23444	55.4	94.0	611
0.875	7.2	1587	23444	68.3	80.1	642
0.750	7.0	1533	23919	82.6	64.4	622
0.625	6.5	1436	24637	95.2	47.9	536
0.500	5.9	1308	25690	106.9	32.4	407
0.375	5.3	1169	27025	118.0	19.1	265
0.250	4.8	1059	28220	127.5	9.1	136
0.000	4.3	959	29652	133.9	0.0	0

METRIC DATA

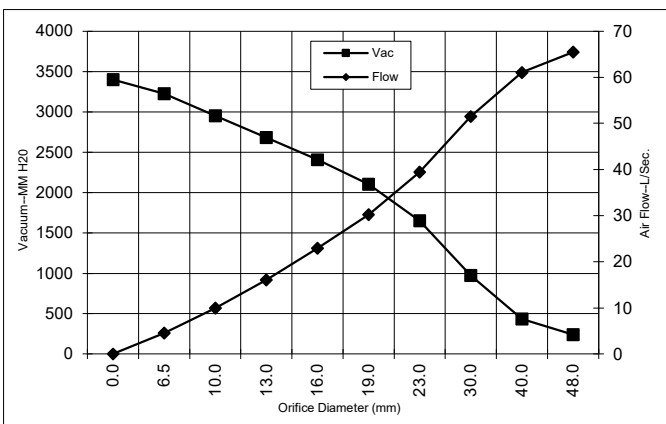

Orifice (mm)	Amps	Watts (In)	RPM	Vac (mm H2O)	Flow (L/Sec)	Air Watts
48.0	7.4	1611	23276	240	65.5	153
40.0	7.4	1607	23304	437	61.1	259
30.0	7.3	1589	23400	975	51.5	488
23.0	7.2	1588	23444	1653	39.5	634
19.0	7.0	1531	23933	2103	30.2	621
16.0	6.5	1440	24608	2406	22.9	539
13.0	6.0	1321	25585	2685	16.0	420
10.0	5.4	1190	26825	2954	10.0	286
6.5	4.8	1064	28160	3227	4.5	143
0.0	4.3	959	29652	3401	0.0	0

Note: Metric Performance data is calculated from the ASTM data above.

* Data represents performance of a typical motor sampled from a large production quantity. Individual motor data may vary due to normal manufacturing variations.

Test Specs:	230 Volts	Minimum Sealed Vacuum:	120.0	ORIFICE:	7/8"	Min. Vacuum:	62.0	Maximum Watts:	1650
-------------	-----------	------------------------	-------	----------	------	--------------	------	----------------	------

DIMENSIONS



NOTES:

1. LEADS: 18GA. STRANDED, POWER LEADS BLACK AND WHITE. GROUNDING LEAD GREEN OR GREEN WITH YELLOW STRIPE.
2. MOTOR IDENTIFICATION: MANUFACTURER'S NAME, MODEL NUMBER, VOLTAGE, FREQUENCY, INSPECTORS CODE WITH "FF" SUFFIX, DATE OF MANUFACTURE, AGENCY RECOGNITION CODE, PLANT LOCATION CODE, PATENT PENDING* AND COUNTRY OF ORIGIN.
3. MOUNTING MUST NOT RESTRICT THIS DIAMETER.
4. ALLOW [0.0025 SQ M]/4.0 SQ IN. (MIN.) FOR COOLING AIR INTAKE.
5. COOLING AIR INTAKE MUST BE SEPARATED FROM COOLING AIR EXHAUST.
6. COOLING AIR EXHAUST MUST BE SEPARATED FROM VACUUM EXHAUST.

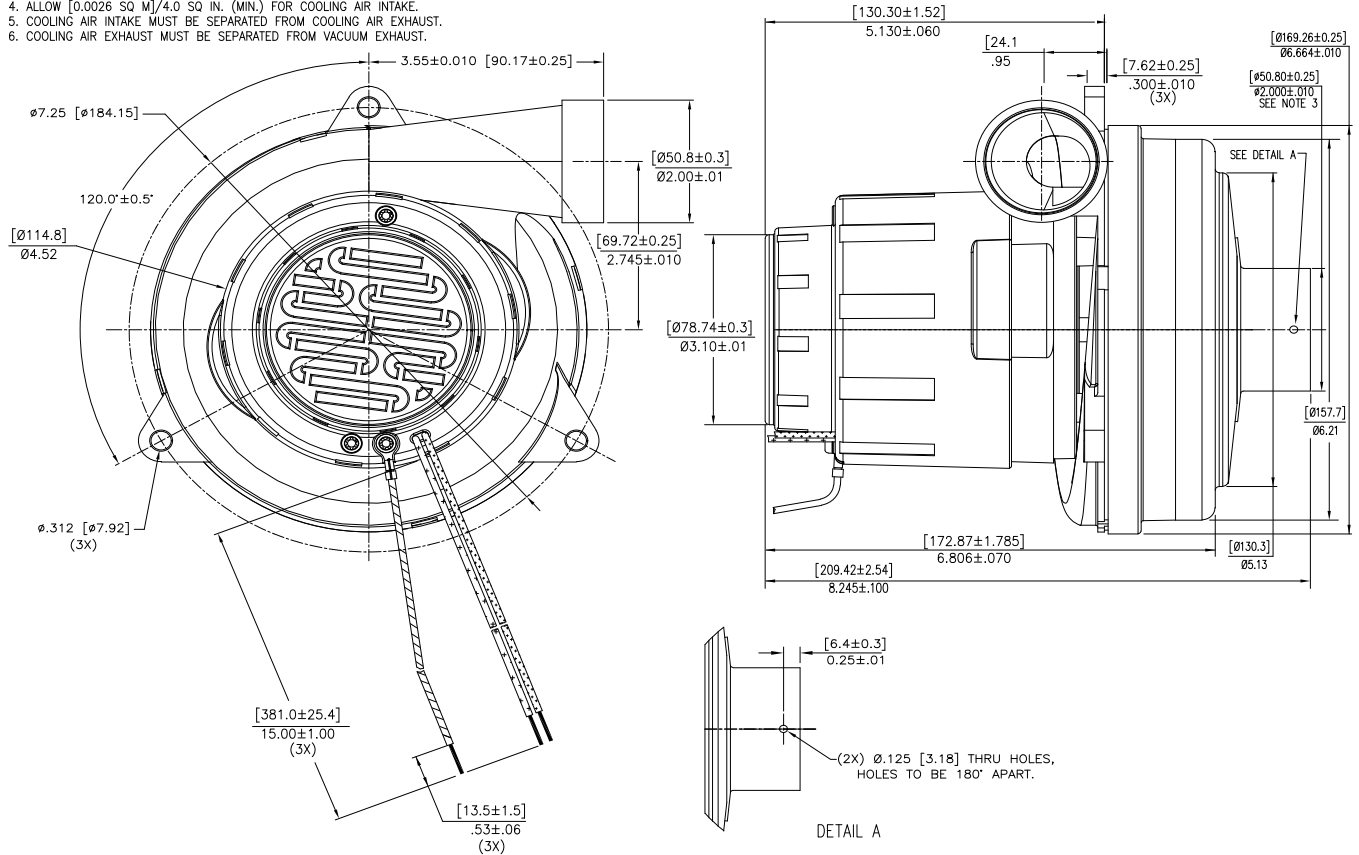

IMPORTANT NOTE: Pictorial and dimensional data are subject to change without notice. Contact factory for current revision levels.

WARNING - When using AMETEK /Lamb Electric bypass motors in machines that come in contact with foam, liquid (including water), or other foreign substances, the machine must be designed and constructed to prevent those substances from reaching the fan system, motor housing, and electrical components. Lamb vacuum motors other than hazardous duty models should not be applied in machines that come in contact with dry chemicals or other volatile materials. Failure to observe these precautions could cause flashing (depending on volatility) or electrical shock which could result in property damage and severe bodily injury, including death in extreme cases. All applications incorporating AMETEK Lamb motors should be submitted to appropriate organizations or agencies for testing specifically related to the safety of your equipment.

AMETEK Dynamic Fluid Solutions
www.ametekdfs.com

Revised: August 2021