



Floorcare & Specialty Motors

Model: 122210-00



DESCRIPTION

- 230-240 volts AC
- Single stage tapered fan
- 6.6" / 162 mm diameter
- Improved sound quality
- "True" tangential discharge bracket
- High-Efficiency "Galaxy" lamination
- Double ball bearings; 10mm output

DESIGN APPLICATION

- Commercial and Residential Central Cleaning Systems
- Car wash vac and blower systems
- Equipment operating in environments requiring separation of working air from motor ventilating air
- Designed to handle clean, dry, filtered air only

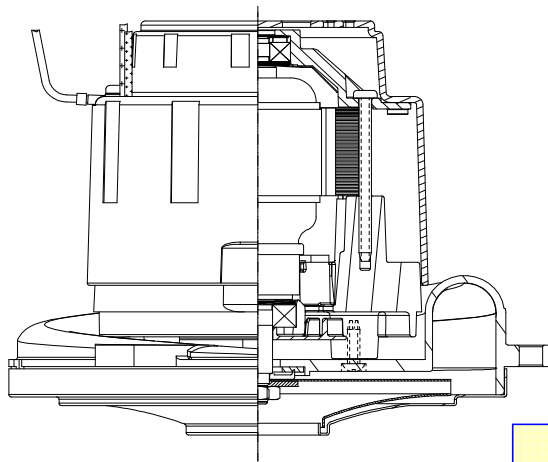

SPECIAL FEATURES

- 1500+ hours life (curved brush)
- 588 Peak Air Watts
- Up to 45% Overall Efficiency
- High efficient cooling system
- Lamb "Green Power Label"
- UL recognized, category PRGY2 (E47185)
- CSA certification pending
- Optional filtered cooling air and locked-rotor, blocked cooling air and running overload protection
- Optional new patent-pending bearing protection for wet applications.

PEAK AIRWATTS
588

Calculated in accordance with ASTM F2105

TYPICAL MOTOR PERFORMANCE.*

(At 240 volts, 60Hz, test data is corrected to standard conditions of 29.92 Hg, 68° F.)

ASTM DATA

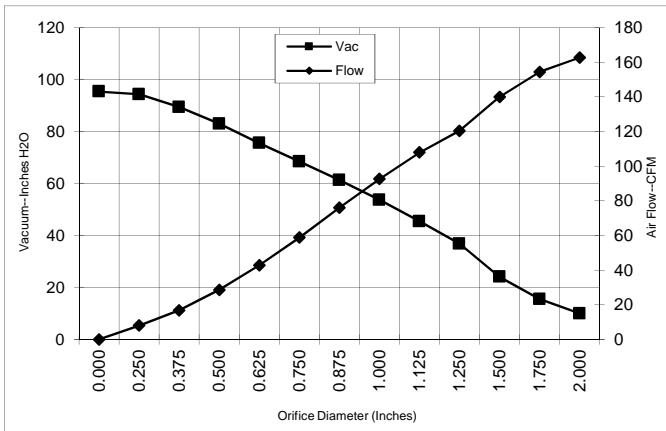

Orifice (Inches)	Amps	Watts (In)	RPM	Vac (In.H2O)	Flow (CFM)	Air Watts
2.000	6.0	1374	24360	10.0	162.8	191
1.750	6.0	1374	24410	15.5	154.5	282
1.500	6.1	1381	24260	24.1	140.1	397
1.250	6.0	1366	24380	36.9	120.5	522
1.125	5.9	1345	24600	45.4	108.0	577
1.000	5.7	1303	24990	53.7	92.7	586
0.875	5.5	1247	25470	61.4	76.0	549
0.750	5.2	1184	26160	68.5	58.9	474
0.625	4.8	1099	27080	75.6	42.9	381
0.500	4.3	1001	28280	83.0	28.7	280
0.375	4.0	919	29500	89.4	16.8	177
0.250	3.7	856	30390	94.4	8.0	89
0.000	3.4	797	31470	95.4	0.0	0

METRIC DATA

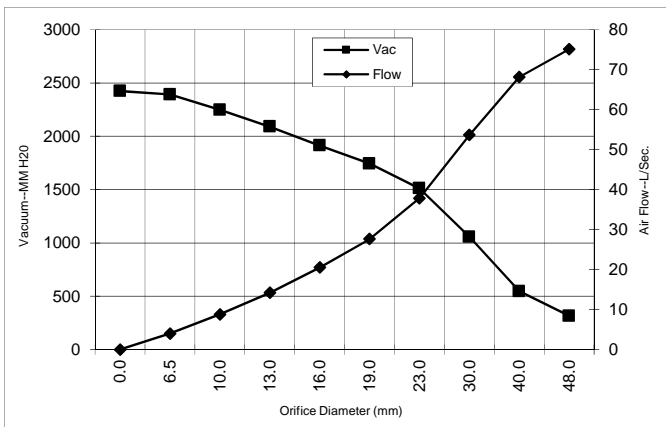

Orifice (mm)	Amps	Watts (In)	RPM	Vac (mm H2O)	Flow (L/Sec)	Air Watts
48.0	6.0	1374	24382	316	75.1	231
40.0	6.0	1379	24305	546	68.1	362
30.0	5.9	1354	24501	1056	53.6	552
23.0	5.5	1261	25350	1510	37.9	558
19.0	5.2	1182	26178	1743	27.6	472
16.0	4.8	1102	27043	1912	20.5	385
13.0	4.4	1011	28160	2090	14.2	290
10.0	4.0	931	29317	2247	8.8	192
6.5	3.7	859	30346	2391	4.0	93
0.0	3.4	797	31470	2423	0.0	0

Note: Metric Performance data is calculated from the ASTM data above.

* Data represents performance of a typical motor sampled from a large production quantity. Individual motor data may vary due to normal manufacturing variations.

Test Specs:	120	Minimum Sealed Vacuum:	90"	ORIFICE:	7/8"	Minimum Vacuum:	57"	Maximum Watts:	1320
--------------------	-----	-------------------------------	-----	-----------------	------	------------------------	-----	-----------------------	------

DIMENSIONS

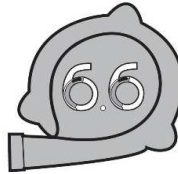

NOTES:

1. LEADS: 18GA. STRANDED. GROUNDING LEAD GREEN OR GREEN WITH YELLOW STRIPE.
2. MOTOR IDENTIFICATION: MANUFACTURER'S NAME, MODEL NUMBER, VOLTAGE, FREQUENCY, INSPECTORS CODE WITH "FF" SUFFIX, DATE OF MANUFACTURE, AGENCY RECOGNITION CODE, PLANT LOCATION CODE, PATENT PENDING" AND COUNTRY OF ORIGIN.
3. MOUNTING MUST NOT RESTRICT THIS DIAMETER.
4. ALLOW [0.0026 SQ M]/4.0 SQ IN. (MIN.) FOR COOLING AIR INTAKE.
5. COOLING AIR INTAKE MUST BE SEPARATED FROM COOLING AIR EXHAUST.
6. COOLING AIR EXHAUST MUST BE SEPARATED FROM VACUUM EXHAUST.

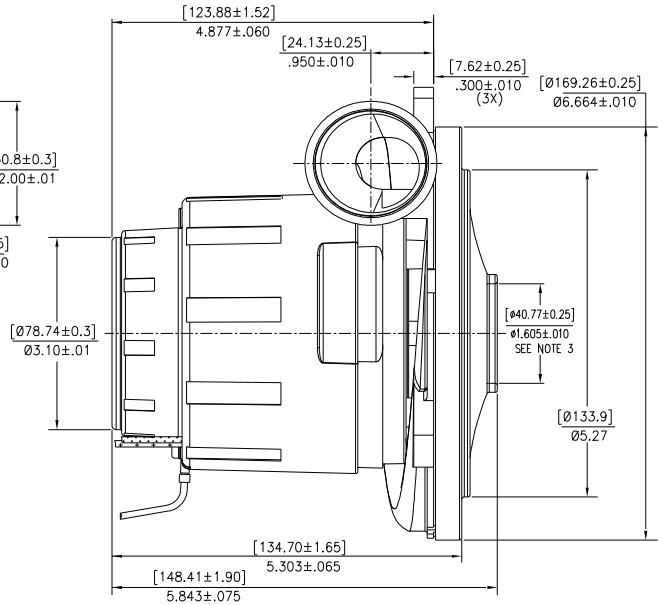
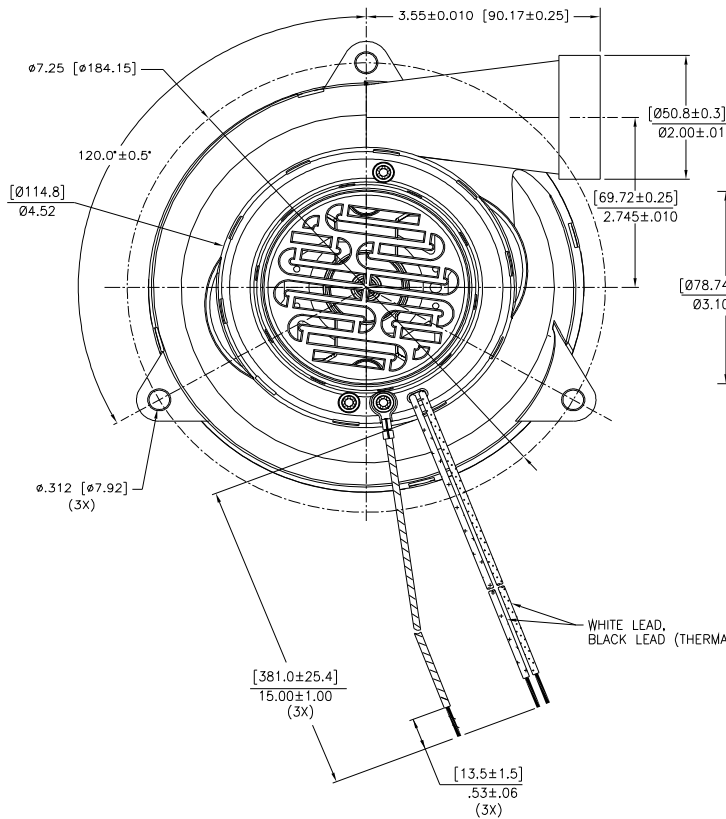

WHITE LEAD,
BLACK LEAD (THERMAL DEVICE).

IMPORTANT NOTE: Pictorial and dimensional data are subject to change without notice. Contact factory for current revision levels.

WARNING - When using AMETEK Floorcare & Specialty Motors (F&SM) bypass motors in machines that come in contact with foam, liquid (including water), or other foreign substances, the machine must be designed and constructed to prevent those substances from reaching the fan system, motor housing, and electrical components. F&SM vacuum motors other than hazardous duty models should not be applied in machines that come in contact with dry chemicals or other volatile materials. Failure to observe these precautions could cause flashing (depending on volatility) or electrical shock which could result in property damage and severe bodily injury, including death in extreme cases. All applications incorporating F&SM motors should be submitted to appropriate organizations or agencies for testing specifically related to the safety of your equipment.

AMETEK/Floorcare & Specialty Motors
www.ametekfsm.com

Modified: May 2016