



**AMETEK**

**LAMB ELECTRIC**



**Product Bulletin**

**Model: 122124-45**

**DESCRIPTION**

- Three stage
- 24 volts
- 5.7"/145 mm diameter
- Double ball bearings
- Single speed
- ACUSTEK® low-noise peripheral bypass discharge
- Thermoset fan end bracket
- Thermoset commutator bracket

**DESIGN APPLICATION**

- Equipment operating in environments requiring separation of working air from motor ventilating air
- Designed to handle clean, dry, filtered air only

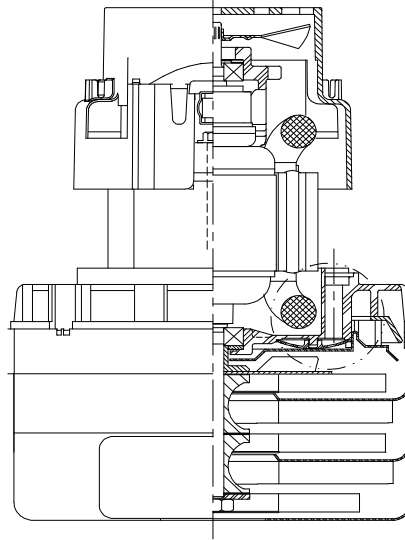

**SPECIAL FEATURES**

- Suitable for 24 volt DC operation
- UL Recognized, category PRGY2 (E47185)
- Provision for grounding
- Skeleton-frame design
- Epoxy painted fan case
- Patented air seal bearing construction. U.S. Patent #4,088,424
- ACUSTEK® low-noise design, U.S. Patent #1,417,200
- The Lamb Electric vacuum motor line offers a wide range of performance levels to meet design needs.
- EMI filtration
- Air Seal
- Connectors

**TYPICAL MOTOR PERFORMANCE.\***

(At 24 volts DC, test data is corrected to standard conditions of 29.92 Hg, 68° F.)

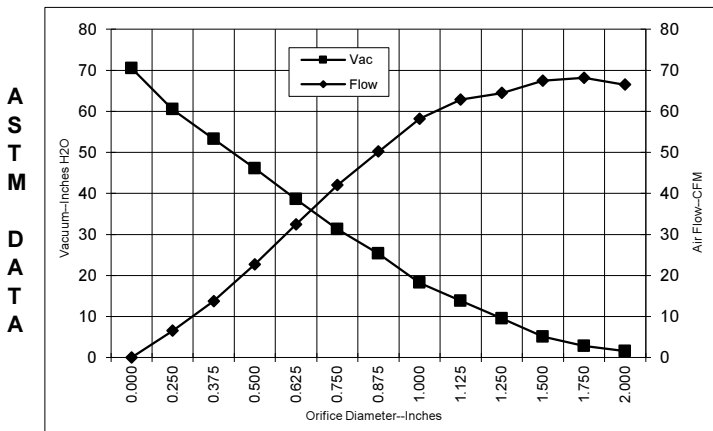

Orifice (Inches)	Amps	Watts (In)	RPM	Vac (In.H <sub>2</sub> O)	Flow (CFM)	Air Watts
2.000	22.5	549	13678	1.6	66.5	12
1.750	22.5	551	13630	2.8	68.2	22
1.500	22.7	554	13566	5.1	67.5	40
1.250	23.0	562	13465	9.5	64.5	72
1.125	23.1	565	13429	13.8	62.9	102
1.000	23.2	566	13411	18.2	58.2	125
0.875	23.2	564	13426	25.3	50.2	149
0.750	22.7	554	13541	31.3	42.0	154
0.625	21.8	532	13951	38.6	32.4	147
0.500	20.6	501	14598	46.1	22.7	123
0.375	19.0	462	15410	53.3	13.7	86
0.250	17.5	426	16280	60.5	6.5	46
0.000	16.5	402	17277	70.5	0.0	0

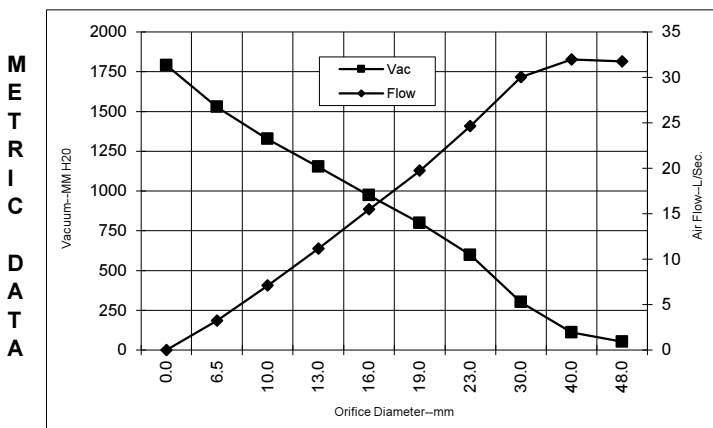

Orifice (mm)	Amps	Watts (In)	RPM	Vac (mm H <sub>2</sub> O)	Flow (L/Sec)	Air Watts
48.0	22.5	550	13657	53	31.7	16
40.0	22.7	553	13585	111	32.0	35
30.0	23.1	564	13445	301	30.0	89
23.0	23.2	565	13422	598	24.6	143
19.0	22.7	554	13549	799	19.7	154
16.0	21.8	533	13935	973	15.5	147
13.0	20.7	504	14533	1152	11.2	125
10.0	19.2	468	15288	1326	7.1	92
6.5	17.6	428	16237	1528	3.2	48
0.0	16.5	402	17277	1791	0.0	0

Note: Metric performance data is calculated from the ASTM data above.

\* Data represents performance of a typical motor sampled from a large production quantity. Individual motor data may vary due to normal manufacturing variations.

<b>Test Specs:</b>	<b>24 volts</b>	<b>Minimum Sealed Vacuum:</b>	<b>62.0"</b>	<b>ORIFICE:</b>	<b>7/8 "</b>	<b>Minimum Vacuum:</b>	<b>22.0"</b>	<b>Maximum Watts:</b>	<b>640</b>
--------------------	-----------------	-------------------------------	--------------	-----------------	--------------	------------------------	--------------	-----------------------	------------

