



Advantek II - Plus

DESCRIPTION

- Two stage
- 240 volts
- 5.7"/145 mm diameter
- Double Ball bearing system
- Single speed
- Thru-flow discharge
- Thermoset fan end bracket
- Stamped steel end bracket

DESIGN APPLICATION

- Equipment operating in environments not requiring separation of working air from motor ventilating air
- Designed to handle clean, dry, filtered air only

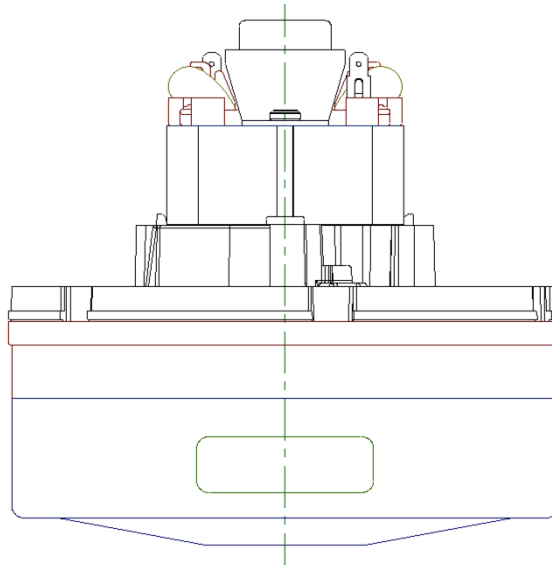

SPECIAL FEATURES

- Suitable for 240 volt AC operation, 50/60 Hz
- UL recognized, category PRGY2 (E47185)
- Provision for grounding per UL 1563
- CSA certified, class 1611 01 (LR31393)
- Skeleton-frame construction
- Patented Advantek diffusion fan system
- Dual Tapered high efficiency fan system
- Self Hold thermal device



TYPICAL MOTOR PERFORMANCE.*

(At 240 volts, 60Hz, test data is corrected to standard conditions of 29.92 Hg, 68° F.)

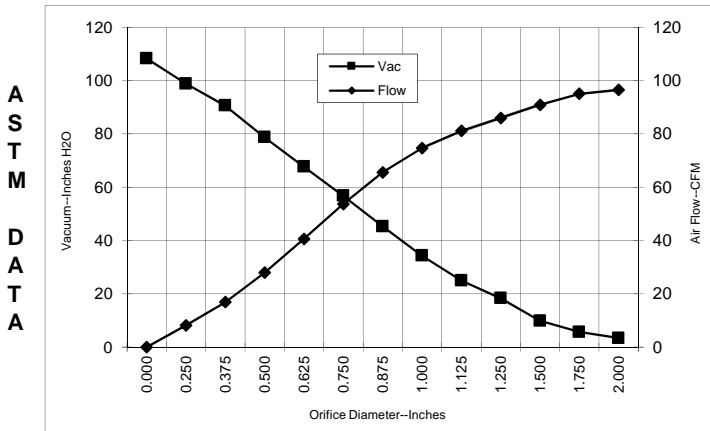

Orifice (Inches)	Amps	Watts (In)	RPM	Vac (In.H2O)	Flow (CFM)	Air Watts
2.000	4.1	944	21460	3.4	96.5	39
1.750	4.1	945	21320	5.7	95.1	63
1.500	4.1	951	21580	9.9	90.9	106
1.250	4.2	955	21540	18.3	86.0	186
1.125	4.2	956	21670	25.0	81.1	239
1.000	4.2	956	21810	34.3	74.7	301
0.875	4.1	946	21550	45.3	65.6	349
0.750	4.0	921	22020	56.7	53.7	359
0.625	3.8	877	22540	67.7	40.6	324
0.500	3.5	812	23520	78.7	28.0	259
0.375	3.2	733	25030	90.6	16.9	180
0.250	2.9	669	26710	98.9	8.2	95
0.000	2.6	619	27880	108.3	0.0	0

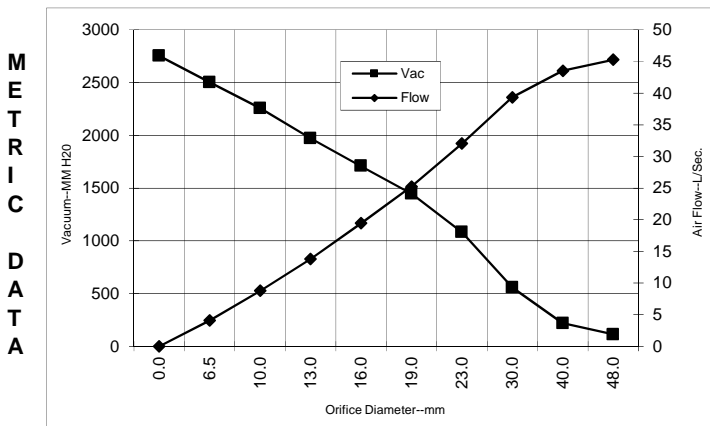

Orifice (mm)	Amps	Watts (In)	RPM	Vac (mm H2O)	Flow (L/Sec)	Air Watts
48.0	4.1	944	21398	112	45.3	50
40.0	4.1	949	21502	219	43.5	93
30.0	4.2	956	21612	559	39.3	215
23.0	4.1	949	21615	1081	32.0	337
19.0	4.0	920	22030	1447	25.2	358
16.0	3.8	879	22519	1708	19.4	325
13.0	3.5	819	23422	1972	13.8	265
10.0	3.2	745	24804	2257	8.8	192
6.5	2.9	672	26626	2501	4.1	99
0.0	2.6	619	27880	2752	0.0	0

Note: Metric Performance data is calculated from the ASTM data above.

* Data represents performance of a typical motor sampled from a large production quantity. Individual motor data may vary due to normal manufacturing variations.

Test Specs:	120 volts	Minimum Sealed Vacuum:	105"	ORIFICE:	7/8 "	Minimum Vacuum:	44"	Maximum Watts:	1050
-------------	-----------	------------------------	------	----------	-------	-----------------	-----	----------------	------



DIMENSIONS

NOTES:

1. MODEL NUMBER, DATE OF MANUFACTURE, PLANT LOCATION CODE, AGENCY RECOGNITION CODE, INSPECTOR'S CODE, MANUFACTURER'S NAME, "US PATENT: US 6,703,754 B1", VOLTAGE AND FREQUENCY, AND CUSTOMER'S PART NO. TO APPEAR ON MOTOR.
2. MOUNTING MUST NOT RESTRICT THIS DIAMETER.
3. LEADS: 18GA STRANDED.
4. GROUNDING OR EARTHING PROVISIONS: USE HOLES AS INDICATED FOR GROUNDING OR EARTHING. REFER TO APPROPRIATE LISTING OR REGULATORY AGENCY FOR PROPER METHOD OF GROUNDING OR EARTHING.

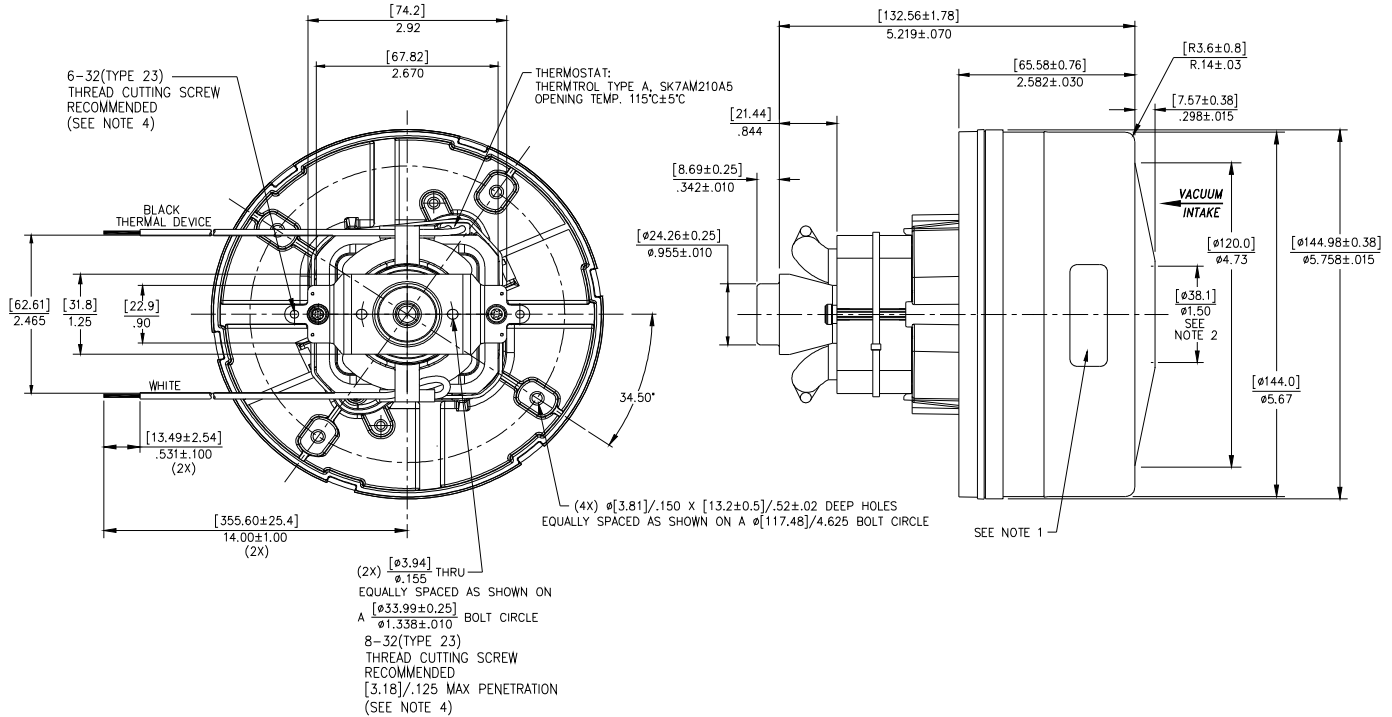

IMPORTANT NOTE: Pictorial and dimensional data are subject to change without notice. Contact factory for current revision levels.

WARNING - AMETEK Lamb Electric thru-flow vacuum motors must never be used in applications in which wet or moist conditions are involved, where dry chemicals or other volatile materials are present, or where airflow may be restricted or blocked. Such motors are designed to permit the vacuumed air to pass over the electrical winding to cool it. Thus any foam, liquid (including water), dry chemical, or other foreign substance coming in contact with electrical conductors could cause combustion (depending on volatility) or electrical shock. Failure to observe these precautions could result in property damage and severe personal injury, including death in extreme cases. All applications incorporating Lamb Electric motors should be submitted to Underwriters Laboratories Inc. or other appropriate organizations or agencies for testing specifically related to the safety of your equipment.

AMETEK/Dynamic Fluid Solutions
www.ametekdfs.com