



# AMETEK LAMB ELECTRIC

## Product Bulletin

Model: 119953-00

### DESCRIPTION

- Single stage
- 120 volts
- 5.7" / 145 mm diameter
- Dual ball bearings
- Single speed
- Acustek bypass discharge
- Thermoset fan end bracket
- Aluminum commutator bracket

### DESIGN APPLICATION

- Equipment operating in environments requiring separation of working air from motor ventilating air
- Designed to handle clean, dry, filtered air only

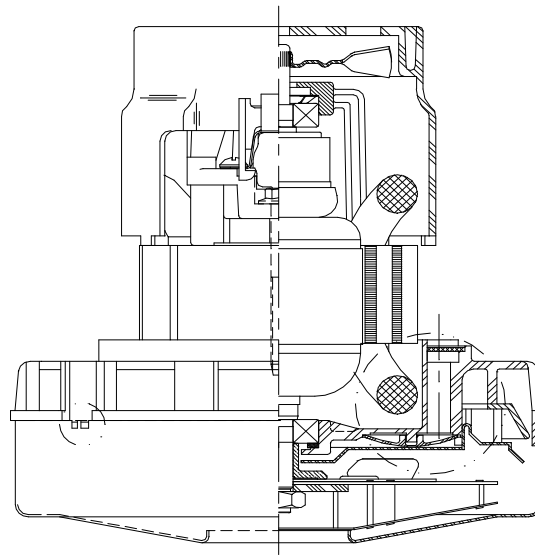

### SPECIAL FEATURES

- Suitable for 120 volt AC operation, 50/60 Hz
- UL recognized, category PRGY2 (E47185)
- Provision for grounding
- Skeleton frame design
- Tapered fan system
- The Lamb vacuum motor line offers a wide range of performance levels to meet design needs



### TYPICAL MOTOR PERFORMANCE.\*

(At 120 volts, 60Hz, test data is corrected to standard conditions of 29.92 Hg, 68° F.)

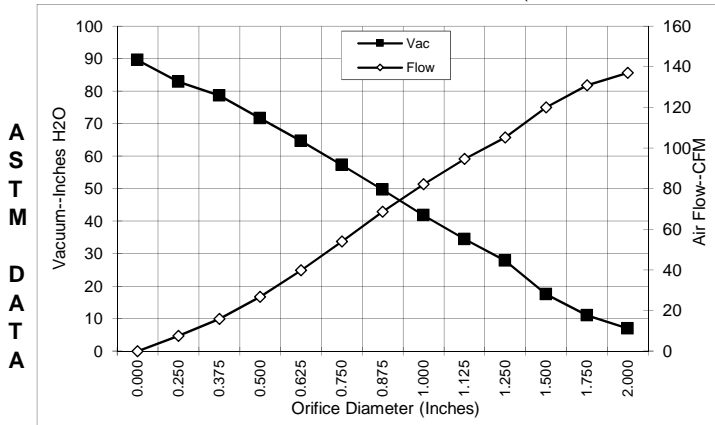

Orifice (Inches)	Amps	Watts (In)	RPM	Vac (In.H <sub>2</sub> O)	Flow (CFM)	Air Watts
2.000	12.5	1437	25715	7.0	137.0	113
1.750	12.5	1443	25645	11.0	130.9	169
1.500	12.5	1441	25590	17.5	120.0	247
1.250	12.3	1423	25810	27.9	105.2	345
1.125	12.1	1397	26435	34.5	94.7	384
1.000	11.8	1364	26465	41.9	82.2	405
0.875	11.4	1317	26945	49.7	68.6	401
0.750	10.9	1259	27635	57.3	54.0	364
0.625	10.2	1184	28585	64.7	39.8	303
0.500	9.4	1097	29780	71.6	26.7	225
0.375	8.7	1011	31235	78.6	15.9	147
0.250	8.0	940	32425	82.9	7.6	74
0.000	7.6	897	33285	89.5	0.0	0

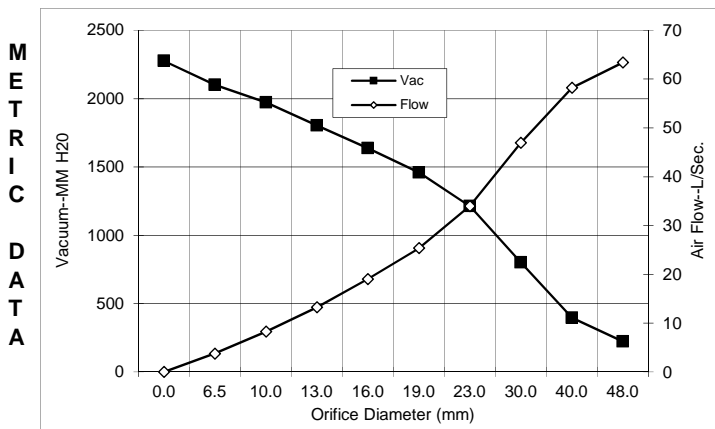

Orifice (mm)	Amps	Watts (In)	RPM	Vac (mm H <sub>2</sub> O)	Flow (L/Sec)	Air Watts
48.0	12.5	1439	25684	222	63.4	138
40.0	12.5	1441	25607	395	58.2	224
30.0	12.2	1408	26154	800	46.9	366
23.0	11.5	1329	26825	1212	34.0	402
19.0	10.8	1257	27654	1458	25.3	362
16.0	10.2	1187	28547	1636	19.0	305
13.0	9.5	1105	29661	1802	13.2	233
10.0	8.8	1023	31017	1971	8.3	158
6.5	8.1	943	32366	2100	3.8	77
0.0	7.6	897	33285	2274	0.0	0

Note: Metric performance data is calculated from the ASTM data above.

\* Data represents performance of a typical motor sampled from a large production quantity. Individual motor data may vary to normal manufacturing variations.

Test Specs:	120v	Minimum Sealed Vacuum:	79"	ORIFICE: 7/8"	Minimum Vacuum:	45"	Maximum Watts:	1420
-------------	------	------------------------	-----	---------------	-----------------	-----	----------------	------

**DIMENSIONS**

**NOTES:**

1. LEADS: 18 GA. STRANDED. LEADS CAN BE ANY COLOR EXCEPT GREEN OR GREEN WITH YELLOW STRIPE.
2. RECOMMENDED SCREW SIZE 10-16 TYPE BT OR 25 THREAD CUTTING SCREW. MAXIMUM PENETRATION [17.40]/.685
3. GROUNDING OR EARTHING: USE HOLES AS INDICATED FOR GROUNDING OR EARTHING. REFER TO APPROPRIATE LISTING OR REGULATORY AGENCY FOR PROPER METHOD OF GROUNDING OR EARTHING.

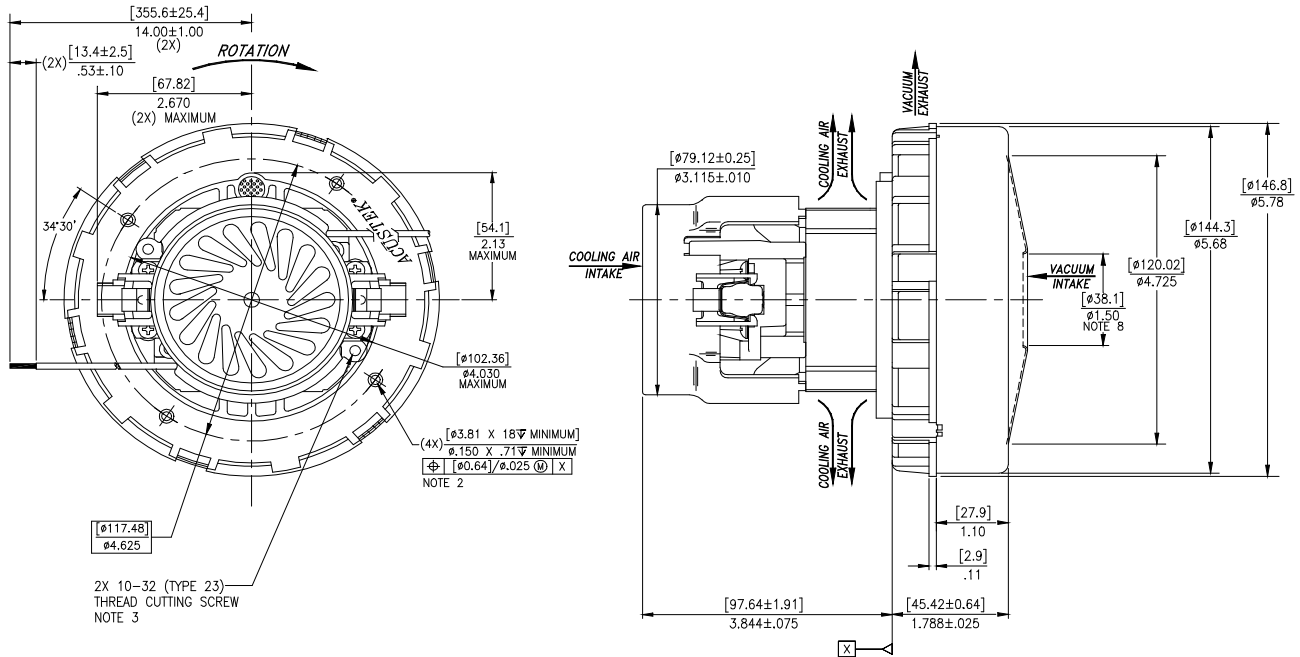

**NOTES: CONTINUED**

4. MANUFACTURER'S NAME, MODEL NUMBER, VOLTAGE, FREQUENCY, INSPECTORS CODE, DATE OF MANUFACTURE, AGENCY RECOGNITION CODE, PLANT LOCATION CODE, "08B ARM", "12B FLD", PATENT INFORMATION: "ONE OR MORE OF THE FOLLOWING PATENTS APPLY TO THIS MOTOR: 5482378; 5736805; 4669952; 4684835." AND "MADE IN THE USA".
5. ALLOW [0.0016 SQUARE M]/2.5 SQUARE INCHES FOR COOLING AIR INTAKE.
6. VACUUM EXHAUST MUST BE SEPERATED FROM COOLING AIR EXHAUST.
7. COOLING AIR INTAKE MUST BE SEPERATED FROM COOLING AIR EXHAUST.
8. MOUNTING MUST NOT RESTRICT THIS DIAMETER.

**IMPORTANT NOTE:** Pictorial and dimensional data are subject to change without notice. Contact factory for current revision levels.

**WARNING** - When using AMETEK/Lamb Electric bypass motors in machines that come in contact with foam, liquid (including water) of other foreign substances, the machine must be designed and constructed to prevent those substances from reaching the fan system, motor housing and electrical components. Lamb vacuum motors other than hazardous duty models should not be applied in machines that come in contact with dry chemicals or other volatile materials. Failure to observe these precautions could cause flashing (depending on volatility) or electrical shock which could result in property damage and severe bodily injury, including death in extreme cases. All applications incorporating Lamb motors should be submitted to appropriate organizations or agencies for testing specifically related to the safety of your equipment.

**AMETEK/Floorcare & Specialty Motors**  
[www.ametekfsm.com](http://www.ametekfsm.com)