



**LAMB ELECTRIC**

**Model: 119921-12**

**AIR WATT™**  
S E R I E S

**SPECIAL FEATURES**

- **600 Peak Air Watts**
- High Efficiency Lamination
- 10 mm shaft and bearing system
- **Self Cleaning Fan System**
- Epoxy painted fan case
- Aluminum brackets to dampen vibration & improve durability
- Suitable for 240 volt AC operation, 50/60 Hz
- UL recognized, category PRGY2 (E47185)
- CSA certified, class 1611 01 (LR31393)
- The Lamb Electric vacuum motor line offers a wide range of performance levels to meet design needs

**DESCRIPTION**

- Two stage
- 240 volts
- **3.5" High Efficiency Lamination**
- 7.2"/183 mm diameter
- Double ball bearings
- **Self Cleaning Fan System**
- Tangential bypass discharge
- Aluminum fan end bracket
- Aluminum commutator bracket

**DESIGN APPLICATION**

- Equipment operating in environments requiring separation of working air from motor ventilating air
- Designed to handle clean, dry, filtered air only

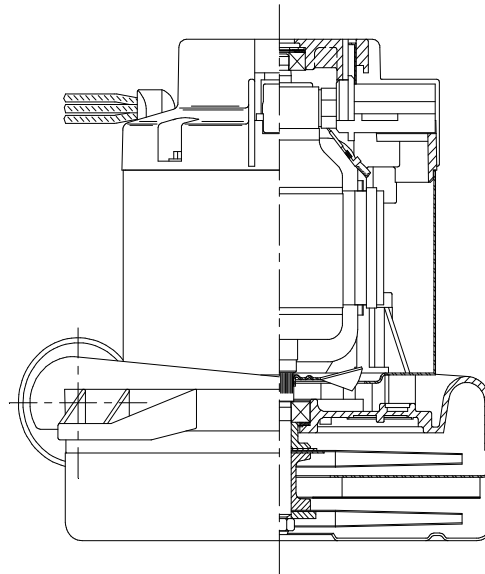

**PEAK AIRWATTS**  
**600**  
Calculated in accordance with ASTM F2105

**TYPICAL MOTOR PERFORMANCE.\***

(At 240 volts, 60Hz, test data is corrected to standard conditions of 29.92 Hg, 68° F.)

**ASTM DATA**

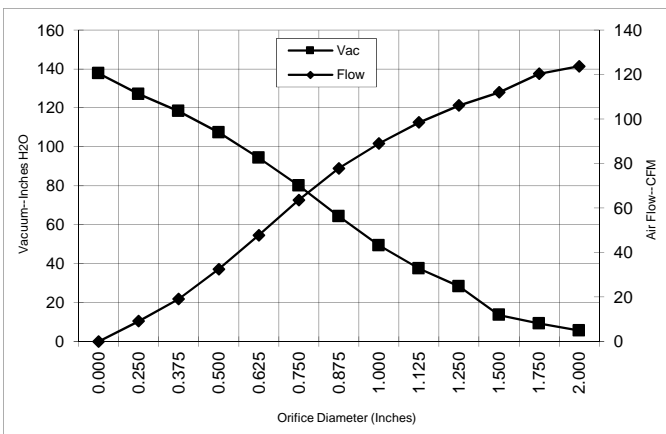

Orifice (Inches)	Amps	Watts (In)	RPM	Vac (In.H2O)	Flow (CFM)	Air Watts
2.000	8.1	1846	23687	5.7	123.7	82
1.750	8.2	1851	23713	9.2	120.3	131
1.500	8.1	1849	24487	13.6	112.0	170
1.250	8.2	1849	21270	28.3	106.1	353
1.125	8.2	1849	21287	37.5	98.5	434
1.000	8.1	1836	21353	49.4	89.0	517
0.875	8.0	1814	21503	64.3	77.8	588
0.750	7.7	1753	21857	80.1	63.6	599
0.625	7.2	1647	22497	94.3	47.8	530
0.500	6.6	1508	23403	107.3	32.5	411
0.375	5.9	1353	24513	118.3	19.2	267
0.250	5.0	1208	25207	127.1	9.1	137
0.000	4.8	1105	26594	137.7	0.0	0

**METRIC DATA**

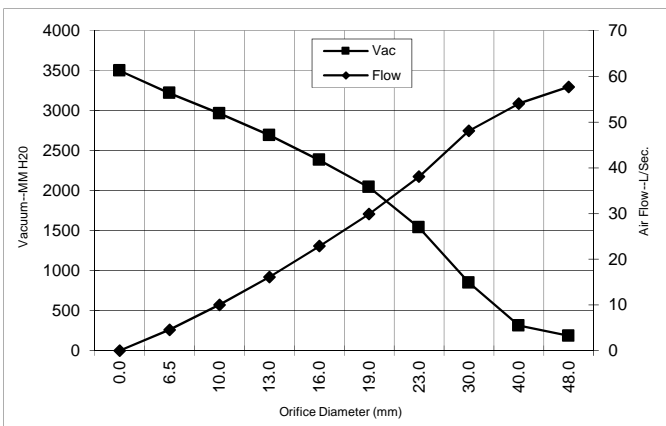

Orifice (mm)	Amps	Watts (In)	RPM	Vac (mm H2O)	Flow (L/Sec)	Air Watts
48.0	8.1	1848	23698	184	57.7	104
40.0	8.1	1849	24255	312	54.0	158
30.0	8.2	1849	21279	847	48.1	398
23.0	8.0	1819	21466	1538	38.0	570
19.0	7.7	1751	21870	2042	29.9	598
16.0	7.2	1652	22471	2382	22.8	533
13.0	6.6	1522	23313	2693	16.1	423
10.0	6.0	1376	24347	2963	10.0	288
6.5	5.1	1215	25172	3217	4.6	143
0.0	4.8	1105	26594	3497	0.0	0

Note: Metric Performance data is calculated from the ASTM data above.

\* Data represents performance of a typical motor sampled from a large production quantity. Individual motor data may vary due to normal manufacturing variations.

<b>Test Specs:</b>	240	<b>Minimum Sealed Vacuum:</b> 127"	<b>ORIFICE:</b> 7/8"	<b>Minimum Vacuum:</b> 60"	<b>Maximum Watts:</b> 1850
--------------------	-----	------------------------------------	----------------------	----------------------------	----------------------------

