



**LAMB ELECTRIC**

**Model: 119890-00**

**DESCRIPTION**

- One stage
- 120 volts
- 4.3" / 106 mm diameter
- Dual ball bearings
- Single speed
- Thru-flow discharge
- Thermal set fan end bracket
- Metal commutator bracket

**DESIGN APPLICATION**

- Equipment operating in environments requiring separation of working air from motor ventilating air
- Designed to handle clean, dry, filtered air only

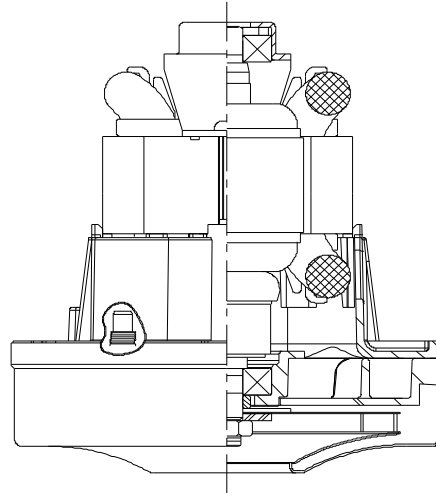

**SPECIAL FEATURES**

- Suitable for 120 volt AC operation, 50/60 Hz
- UL recognized, category PRGY2 (E47185)
- Provision for grounding
- The Lamb vacuum motor line offers a wide range of performance levels to meet design needs

**TYPICAL MOTOR PERFORMANCE.\***

(At 120 volts DC, test data is corrected to standard conditions of 29.92 Hg, 68° F.)

**ASTM DATA**

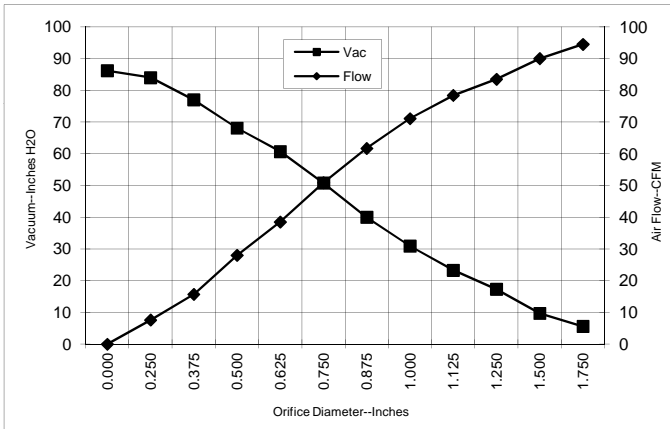

Orifice (Inches)	Amps	Watts (In)	RPM	Vac (In.H <sub>2</sub> O)	Flow (CFM)	Air Watts
2.000	6.9	814	34820	4.4	96.3	38
1.750	6.8	807	34820	5.6	94.5	62
1.500	6.9	817	34820	9.7	90.0	103
1.250	6.9	811	34820	17.3	83.5	170
1.125	6.9	815	35210	23.3	78.4	215
1.000	6.8	804	35210	30.9	71.1	259
0.875	6.7	787	35600	40.0	61.7	290
0.750	6.5	775	36400	50.8	50.9	305
0.625	6.3	742	37580	60.7	38.5	275
0.500	5.9	700	39580	68.1	28.0	209
0.375	5.4	646	41940	77.0	15.7	142
0.250	5.0	604	43920	84.0	7.6	75
0.000	4.8	572	46290	86.2	0.0	0

**METRIC DATA**

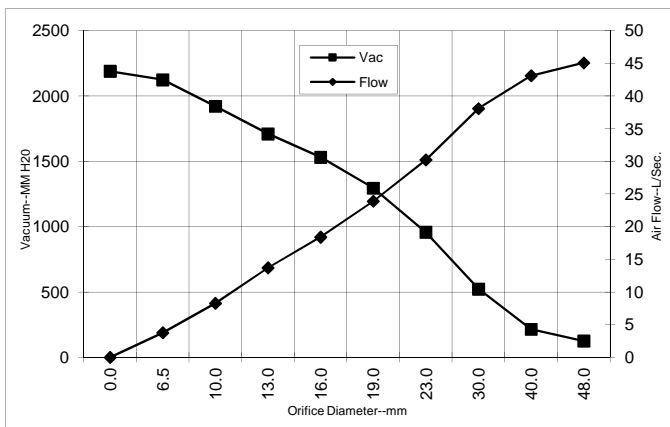

Orifice (mm)	Amps	Watts (In)	RPM	Vac (mm H <sub>2</sub> O)	Flow (L/Sec)	Air Watts
48.0	6.9	811	34820	125	45.1	49
40.0	6.9	814	34820	215	43.1	91
30.0	6.9	813	35035	523	38.1	195
23.0	6.7	791	35503	958	30.2	282
19.0	6.5	774	36424	1295	23.9	304
16.0	6.3	743	37533	1532	18.4	276
13.0	5.9	704	39380	1711	13.7	216
10.0	5.5	654	41586	1922	8.3	152
6.5	5.0	606	43821	2125	3.8	78
0.0	4.8	572	46290	2189	0.0	0

Note: Metric performance data is calculated from the ASTM data above.

\* Data represents performance of a typical motor sampled from a large production quantity. Individual motor data may vary due to normal manufacturing variations.

<b>Test Specs: 120 volts</b>	<b>Minimum Sealed Vacuum: 72.0"</b>	<b>ORIFICE: 7/8"</b>	<b>Minimum Vacuum: 36.5"</b>	<b>Maximum Watts: 780</b>
------------------------------	-------------------------------------	----------------------	------------------------------	---------------------------

**DIMENSIONS**

**NOTES:**

1. MODEL NUMBER, DATE OF MANUFACTURE, PLANT LOCATION CODE, AGENCY RECOGNITION CODE, INSPECTOR'S CODE, MANUFACTURER'S NAME, "THERMALLY PROTECTED 1.6/3 AMP", "US PATENT: US 6,703,764 B1 & PATENTS PENDING", VOLTAGE AND FREQUENCY TO APPEAR ON MOTOR

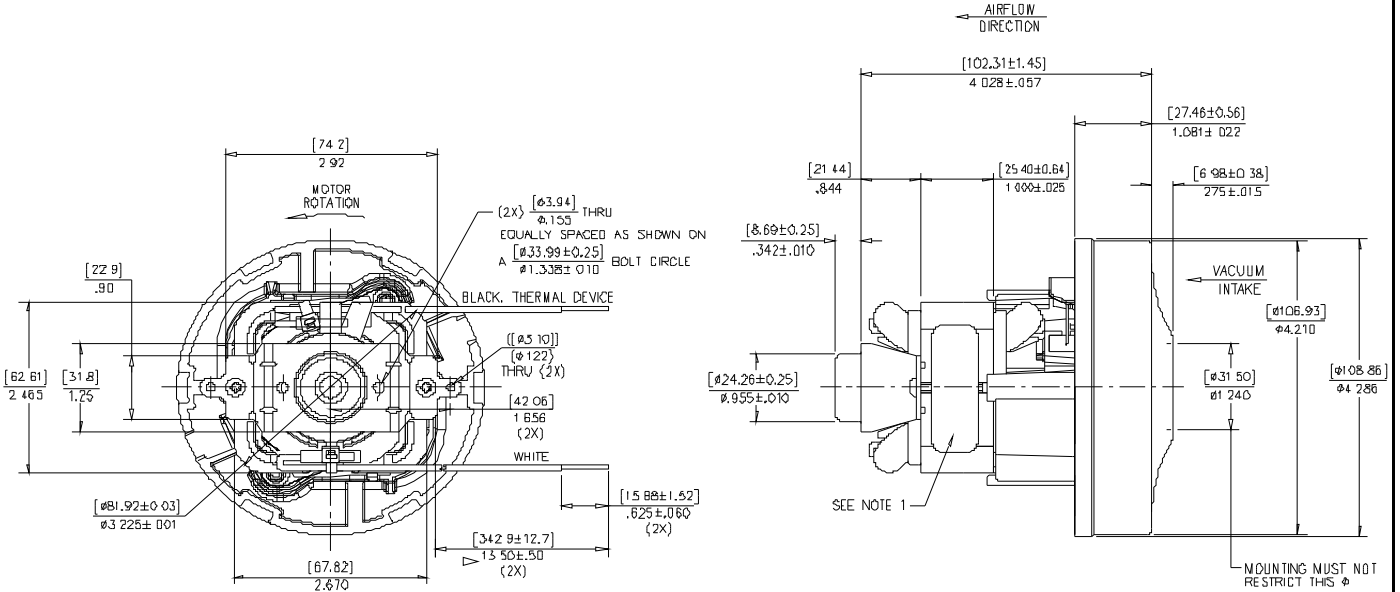

**IMPORTANT NOTE:** Pictorial and dimensional data are subject to change without notice. Contact factory for current revision levels.

**WARNING** - When using AMETEK Lamb Electric bypass motors in machines that come in contact with foam, liquid (including water), or other foreign substances, the machine must be designed and constructed to prevent those substances from reaching the fan system, motor housing, and electrical components. Lamb Electric vacuum motors other than hazardous duty models should not be applied in machines that come in contact with dry chemicals or other volatile materials. Failure to observe these precautions could cause flashing (depending on volatility) or electrical shock which could result in property damage and severe bodily injury, including death in extreme cases. All applications incorporating Lamb Electric motors should be submitted to appropriate organizations or agencies for testing specifically related to the safety of your equipment.

**AMETEK/Floorcare & Specialty Motors**  
**www.ametekfsm.com**