



AMETEK LAMB ELECTRIC

Product Bulletin

Model: 119887-19

DESCRIPTION

- Two stage
- 240 volts
- 5.7"/145 mm diameter
- Double ball bearings
- Single speed
- Peripheral bypass discharge
- Thermoset plastic fan end bracket
- Aluminum commutator bracket

DESIGN APPLICATION

- Equipment operating in environments requiring separation of working air from motor ventilating air
- Designed to handle clean, dry, filtered air only

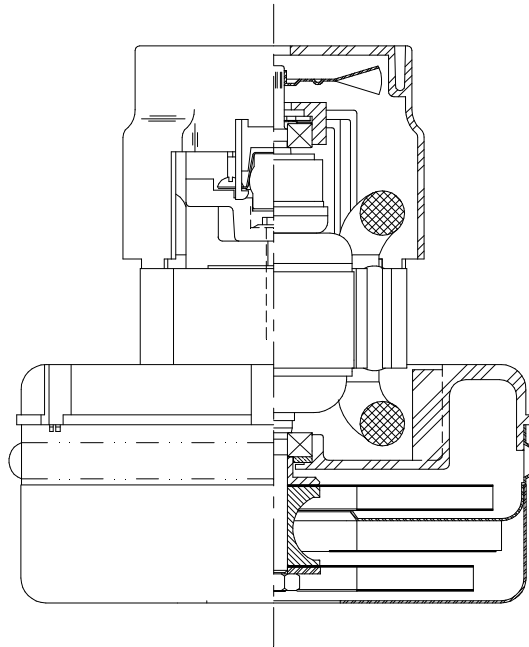

SPECIAL FEATURES

- Suitable for 240 volt AC operation, 50/60 Hz
- UL recognized, category PRGY2 (E47185)
- CSA certified, class 1611 01 (LR31393)
- Provision for grounding
- Open frame design
- The Lamb Electric vacuum motor line offers a wide range of performance levels to meet design needs

TYPICAL MOTOR PERFORMANCE.*

(At 240 volts, 60Hz, test data is corrected to standard conditions of 29.92 Hg, 68° F.)

ASTM DATA

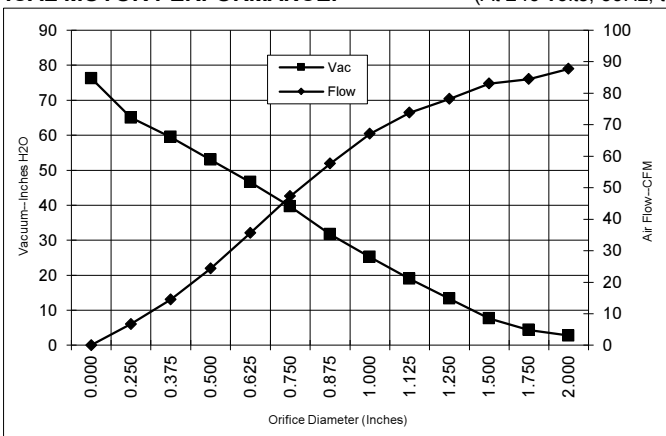

Orifice (Inches)	Amps	Watts (In)	RPM	Vac (In.H ₂ O)	Flow (CFM)	Air Watts
2.000	3.5	766	18333	2.7	87.7	28
1.750	3.5	766	18280	4.3	84.5	42
1.500	3.6	776	18227	7.6	83.0	74
1.250	3.6	781	18068	13.3	78.2	120
1.125	3.6	781	18015	19.0	73.8	165
1.000	3.6	778	17273	25.2	67.1	199
0.875	3.5	757	17273	31.7	57.6	215
0.750	3.4	735	18280	39.6	47.3	220
0.625	3.3	706	18788	46.6	35.6	195
0.500	3.1	671	19477	53.0	24.3	151
0.375	2.8	633	20346	59.5	14.5	101
0.250	2.7	584	21194	65.0	6.7	51
0.000	2.4	540	22550	76.2	0.0	0

METRIC DATA

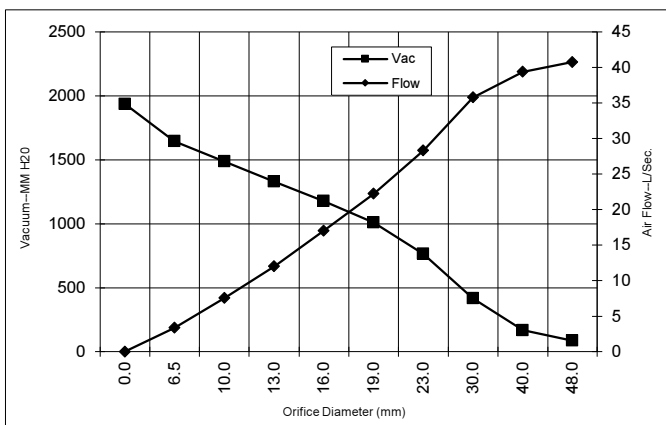

Orifice (mm)	Amps	Watts (In)	RPM	Vac (mm H ₂ O)	Flow (L/Sec)	Air Watts
48.0	3.5	766	18310	86	40.7	34
40.0	3.6	773	18243	168	39.4	64
30.0	3.6	781	18039	417	35.8	145
23.0	3.5	762	17273	764	28.3	211
19.0	3.4	734	18290	1009	22.2	220
16.0	3.3	707	18768	1177	17.0	196
13.0	3.1	675	19408	1330	12.0	155
10.0	2.9	639	20216	1487	7.5	109
6.5	2.7	586	21152	1644	3.3	54
0.0	2.4	540	22550	1935	0.0	0

Note: Metric performance data is calculated from the ASTM data above.

* Data represents performance of a typical motor sampled from a large production quantity. Individual motor data may vary due to normal manufacturing variations.

Test Specs:	240 volts	Minimum Sealed Vacuum:	70.0"	ORIFICE:	7/8 "	Minimum Vacuum:	30.0"	Maximum Watts:	870
-------------	-----------	------------------------	-------	----------	-------	-----------------	-------	----------------	-----

DIMENSIONS

NOTES:

1. LEADS: 18GA STRANDED, LEADS CAN BE ANY COLOR EXCEPT GREEN OR GREEN WITH YELLOW STRIPE.
2. GROUNDING OR EARTHING PROVISIONS: USE HOLES AS INDICATED FOR GROUNDING OR EARTHING. REFER TO APPROPRIATE LISTING OR REGULATORY AGENCY FOR PROPER METHOD OF GROUNDING OR EARTHING.
3. RECOMMENDED SCREW SIZE 10-16 TYPE BT OR TYPE 25 THREAD CUTTING SCREW, MAXIMUM PENETRATION [17.40]/.685.
4. MOTOR IDENTIFICATION: MANUFACTURER'S NAME, MODEL NUMBER, VOLTAGE, FREQUENCY, INSPECTORS CODE, DATE OF MANUFACTURE, AGENCY RECOGNITION CODE, PLANT LOCATION CODE, PATENT INFORMATION, ONE OR MORE OF THE FOLLOWING PATENTS APPLY TO THIS MOTOR: 5482378; 5736805; 4669962; 4684835. AND COUNTRY OF ORIGIN.
5. ALLOW [0.0016 SQ MI]/2.5 SQ IN. MIN. FOR COOLING AIR INTAKE.
6. COOLING AIR INTAKE MUST BE SEPARATED FROM COOLING AIR EXHAUST.
7. VACUUM EXHAUST MUST BE SEPARATED FROM COOLING EXHAUST.
8. MOUNTING MUST NOT RESTRICT THIS DIAMETER.

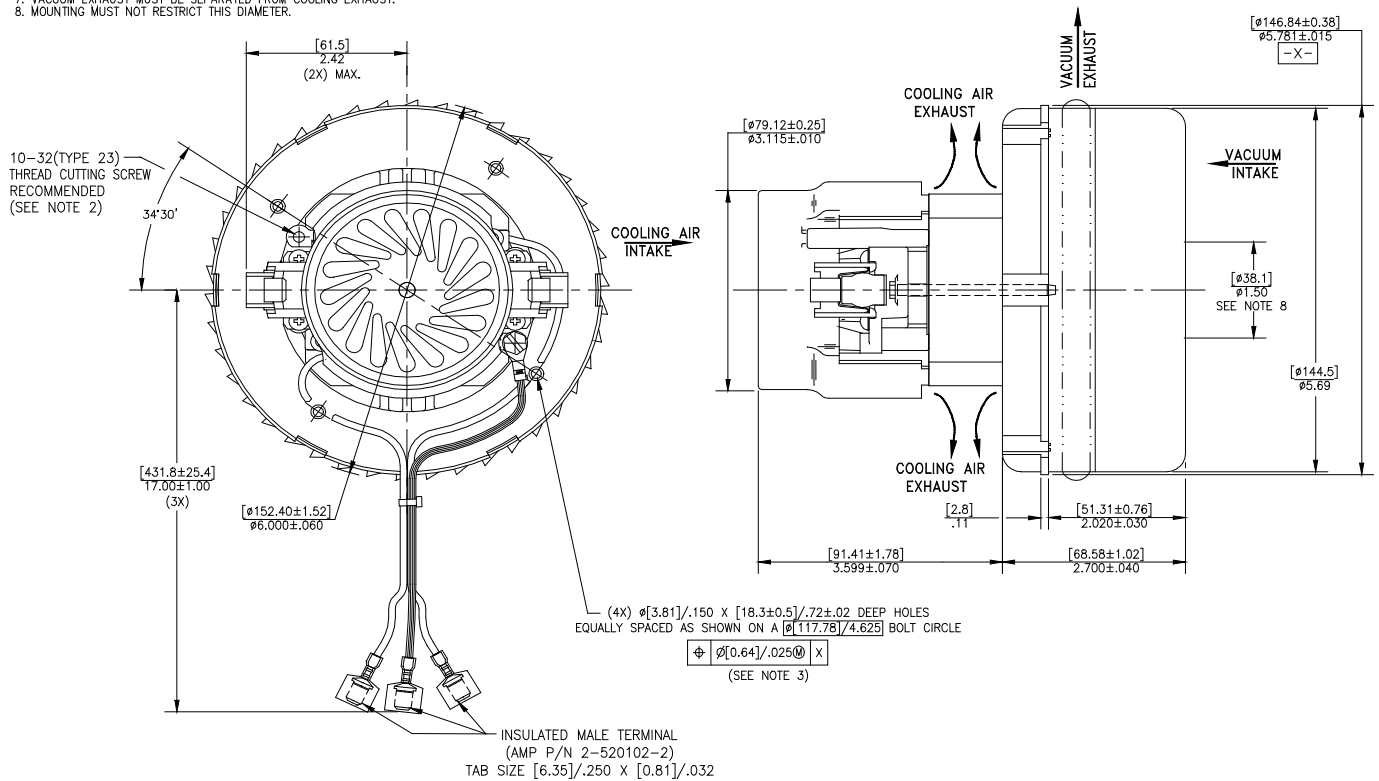

IMPORTANT NOTE: Pictorial and dimensional data are subject to change without notice. Contact factory for current revision levels.

WARNING - When using AMETEK Lamb Electric bypass motors in machines that come in contact with foam, liquid (including water), or other foreign substances, the machine must be designed and constructed to prevent those substances from reaching the fan system, motor housing, and electrical components. Lamb Electric vacuum motors other than hazardous duty models should not be applied in machines that come in contact with dry chemicals or other volatile materials. Failure to observe these precautions could cause flashing (depending on volatility) or electrical shock which could result in property damage and severe bodily injury, including death in extreme cases. All applications incorporating Lamb Electric motors should be submitted to appropriate organizations or agencies for testing specifically related to the safety of your equipment.

AMETEK/Lamb Electric Division
627 Lake Street
Kent, Ohio 44240
U.S.A.
Tel: (330) 673-3786 Fax: (330) 677-3812
www.lambelectric.com