



# AMETEK LAMB ELECTRIC

## Product Bulletin

Model: 119885-13

### DESCRIPTION

- Three stage
- 120 volts
- 5.7"/ 145 mm diameter
- Dual ball bearings
- Single speed
- Tangential bypass discharge
- Thermoset fan end bracket
- Aluminum commutator bracket

### DESIGN APPLICATION

- Equipment operating in environments requiring separation of working air from motor ventilating air
- Designed to handle clean, dry, filtered air only

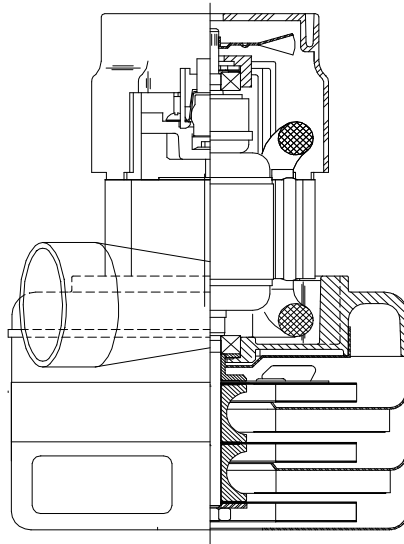

### SPECIAL FEATURES

- Suitable for 120 volt AC operation, 50/60 Hz
- UL recognized, category PRGY2 (E47185)
- Provision for grounding
- Skeleton frame design
- "-13" denotes patented air seal bearing system
- The Lamb vacuum motor line offers a wide range of performance levels to meet design needs

### TYPICAL MOTOR PERFORMANCE.\*

(At 120 volts, 60Hz, test data is corrected to standard conditions of 29.92 Hg, 68° F.)

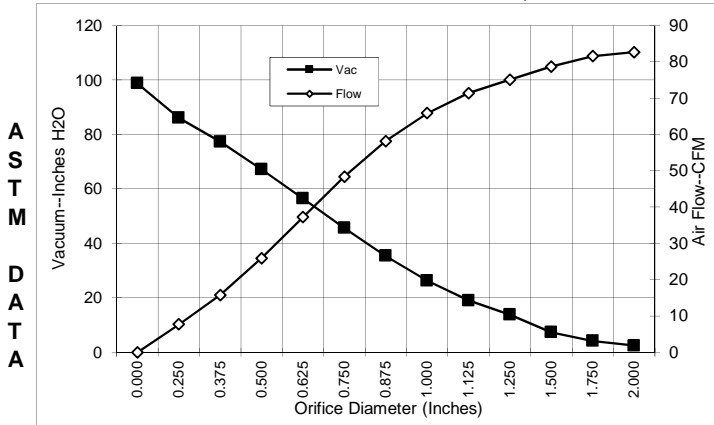

Orifice (Inches)	Amps	Watts (In)	RPM	Vac (In.H <sub>2</sub> O)	Flow (CFM)	Air Watts
2.000	7.9	903	18425	2.5	82.7	24
1.750	7.9	904	18320	4.1	81.6	40
1.500	7.9	907	18320	7.3	78.7	68
1.250	8.0	912	18320	13.8	75.1	122
1.125	8.0	917	18220	19.1	71.4	160
1.000	8.0	922	18120	26.3	65.9	204
0.875	8.0	919	18220	35.4	58.2	242
0.750	7.8	893	18520	45.6	48.4	260
0.625	7.4	847	19120	56.4	37.2	247
0.500	6.8	787	19995	67.2	25.9	205
0.375	6.2	721	21180	77.3	15.7	143
0.250	5.7	669	22380	86.1	7.7	78
0.000	5.3	622	23350	98.8	0.0	0

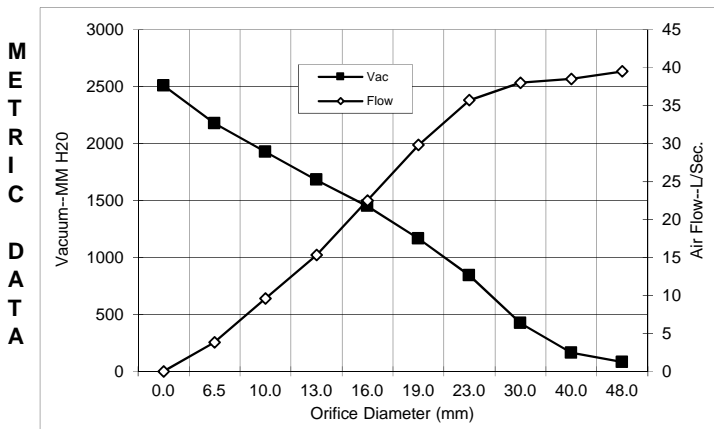

Orifice (mm)	Amps	Watts (In)	RPM	Vac (mm H <sub>2</sub> O)	Flow (L/Sec)	Air Watts
48.0	7.9	903	18379	81	39.5	31
40.0	7.9	906	18320	162	38.5	60
30.0	8.0	915	18265	424	38.0	143
23.0	8.0	920	18195	841	35.7	515
19.0	7.8	892	18532	1164	29.8	528
16.0	7.4	849	19096	1450	22.5	470
13.0	6.8	793	19908	1680	15.3	209
10.0	6.3	731	21002	1926	9.6	152
6.5	5.7	672	22320	2176	3.8	81
0.0	5.3	622	23350	2508	0.0	0

Note: Metric performance data is calculated from the ASTM data above.

\* Data represents performance of a typical motor sampled from a large production quantity. Individual motor data may vary to normal manufacturing variations.

Test Specs:	120 volt	Minimum Sealed Vacuum: 76	93.0"	ORIFICE: 7/8"	Minimum Vacuum: 31.0"	Maximum Watts: 995
-------------	----------	---------------------------	-------	---------------	-----------------------	--------------------

**DIMENSIONS**

**NOTES:**

1. LEADS: 18GA STRANDED, LEADS CAN BE ANY COLOR EXCEPT GREEN OR GREEN WITH YELLOW STRIPE.
2. GROUNDING OR EARTHING PROVISIONS: USE HOLES AS INDICATED FOR GROUNDING OR EARTHING. REFER TO APPROPRIATE LISTING OR REGULATORY AGENCY FOR PROPER METHOD OF GROUNDING OR EARTHING.
3. MOTOR IDENTIFICATION: MANUFACTURER'S NAME, MODEL NUMBER, VOLTAGE, FREQUENCY, INSPECTOR'S CODE, DATE OF MANUFACTURE, AGENCY RECOGNITION CODE, PLANT LOCATION CODE, PATENT INFORMATION "ONE OR MORE OF THE FOLLOWING U.S. PATENTS APPLY TO THIS MOTOR: 5482378; 5736805; 4669952; 4684835" AND COUNTRY OF ORIGIN.
4. ALLOW [0.0016 SQ IN]/2.5 SQ IN. MIN. FOR COOLING AIR INTAKE.
5. COOLING AIR INTAKE MUST BE SEPARATED FROM COOLING AIR EXHAUST.
6. VACUUM EXHAUST MUST BE SEPARATED FROM COOLING AIR EXHAUST.
7. MOUNTING MUST NOT RESTRICT THIS DIAMETER.

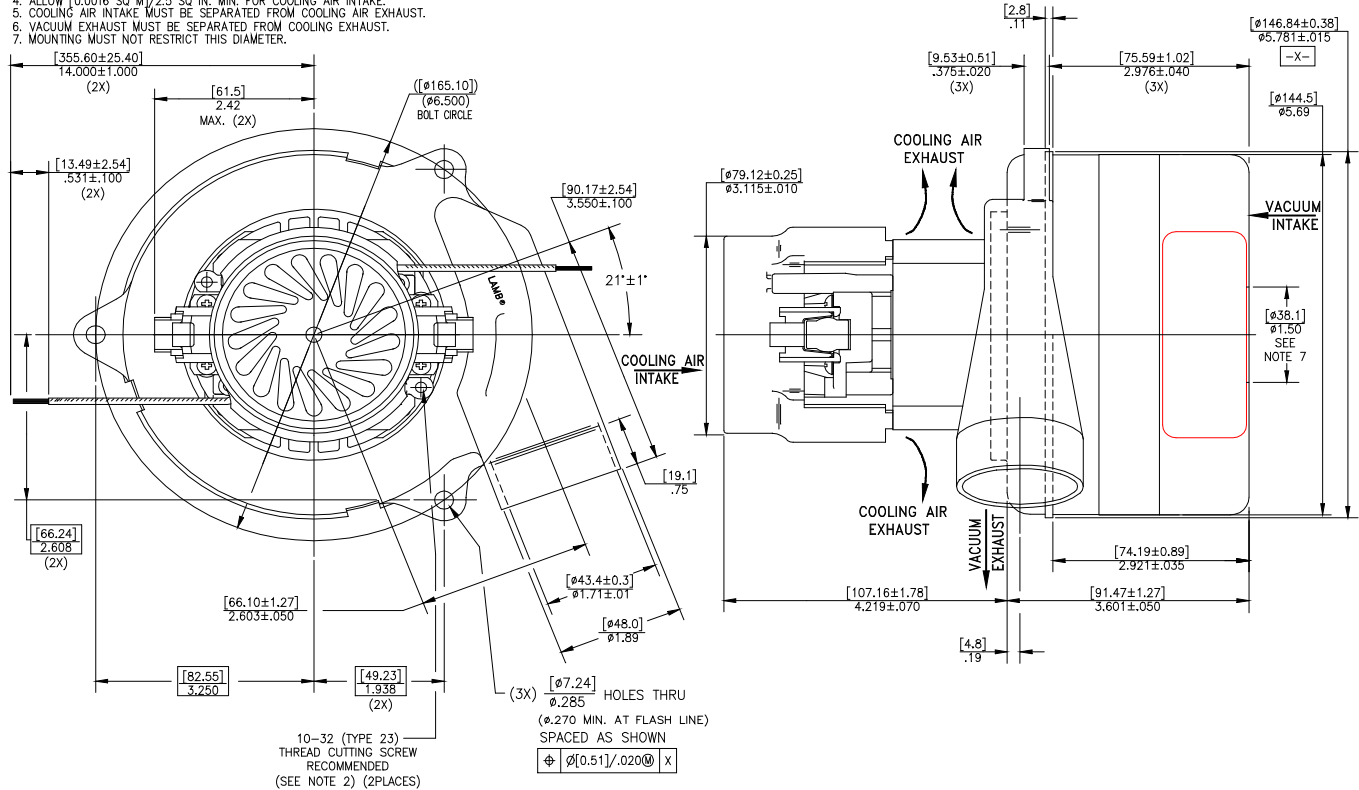

**IMPORTANT NOTE:** Pictorial and dimensional data are subject to change without notice. Contact factory for current revision levels.

**WARNING** - When using AMETEK/Lamb Electric bypass motors in machines that come in contact with foam, liquid (including water) or other foreign substances, the machine must be designed and constructed to prevent those substances from reaching the fan system, motor housing and electrical components. Lamb vacuum motors other than hazardous duty models should not be applied in machines that come in contact with dry chemicals or other volatile materials. Failure to observe these precautions could cause flashing (depending on volatility) or electrical shock which could result in property damage and severe bodily injury, including death in extreme cases. All applications incorporating Lamb motors should be submitted to appropriate organizations or agencies for testing specifically related to the safety of your equipment.

**AMETEK/Floorcare & Specialty Motors**  
[www.ametekfsm.com](http://www.ametekfsm.com)