



Model: 119434-13

DESCRIPTION

- Two stage
- 36 volts
- 5.7"/145 mm diameter
- Double ball bearings
- Single speed
- Tangential bypass discharge
- Thermoset fan end bracket
- Thermoset commutator bracket

DESIGN APPLICATION

- Equipment operating in environments requiring separation of working air from motor ventilating air
- Designed to handle clean, dry, filtered air only

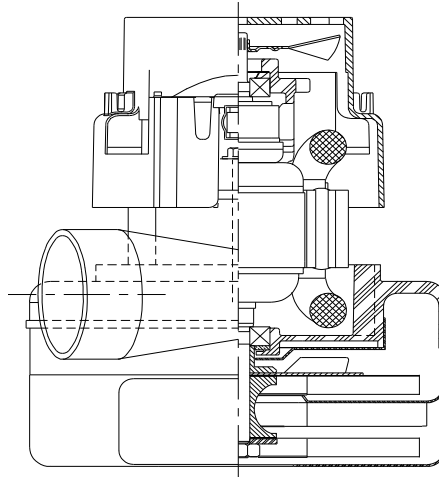

SPECIAL FEATURES

- Suitable for 36 volt DC operation
- Provision for grounding
- UL Recognized, category PRGY2 (E47185)
- Skeleton-frame design
- Fan shell inlet tube
- Epoxy painted fan case
- Patented air seal bearing construction. U.S. Patent #4,088,424
- The Lamb Electric vacuum motor line offers a wide range of performance levels to meet design needs.

Model 119434-13 is the G2K replacement for model 116158-01

TYPICAL MOTOR PERFORMANCE.*

(At 36 volts, 60Hz, test data is corrected to standard conditions of 29.92 Hg, 68° F.)

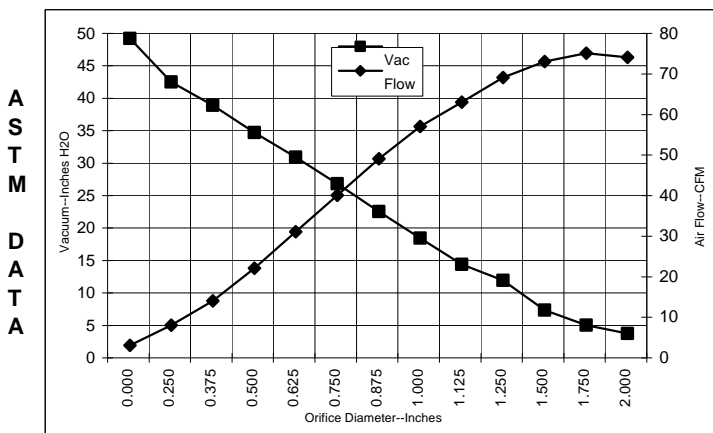

Orifice (mm)	Amps	Watts (In)	RPM	Vac (mm H ₂ O)	Flow (L/Sec)	Air Watts
2.000	10.5	387	13200	1.8	71.0	15
1.750	10.6	391	13200	3.1	72.0	26
1.500	10.6	391	13100	5.4	70.0	44
1.250	10.8	398	13000	10.0	66.0	78
1.125	10.8	398	13000	12.5	60.0	88
1.000	10.8	398	13000	16.5	54.0	105
0.875	10.6	391	13100	20.6	46.0	113
0.750	10.3	380	13350	24.9	37.0	110
0.625	9.7	358	13700	29.0	28.0	96
0.500	9.1	335	14250	32.8	19.0	74
0.375	8.6	317	14850	37.0	11.0	50
0.250	8.0	295	15400	40.6	5.0	25
0.000	7.6	280	16200	47.3	0.0	0

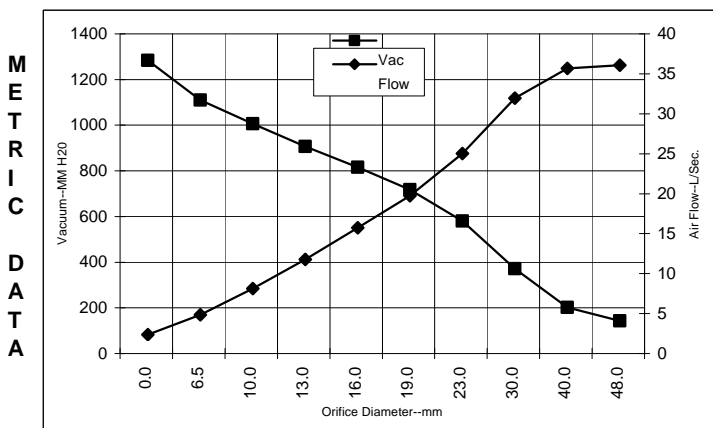

Orifice (mm)	Amps	Watts (In)	RPM	Vac (mm H ₂ O)	Flow (L/Sec)	Air Watts
48.0	10.5	389	13200	60	33.7	20
40.0	10.6	391	13130	120	33.3	39
30.0	10.8	398	13000	289	29.6	84
23.0	10.7	393	13075	497	22.7	111
19.0	10.3	380	13357	635	17.4	110
16.0	9.7	359	13686	732	13.4	97
13.0	9.2	337	14195	823	9.4	76
10.0	8.7	320	14760	924	5.8	54
6.5	8.0	296	15373	1027	2.5	26
0.0	7.6	280	16200	1201	0.0	0

Note: Metric performance data is calculated from the ASTM data above.

* Data represents performance of a typical motor sampled from a large production quantity. Individual motor data may vary due to normal manufacturing variations.

Test Specs:	36 volts	Minimum Sealed Vacuum:	43.0"	ORIFICE:	7/8 "	Minimum Vacuum:	17.0"	Maximum Watts:	480
--------------------	-----------------	-------------------------------	--------------	-----------------	--------------	------------------------	--------------	-----------------------	------------

DIMENSIONS



NOTES:

1. LEADS: 14 GA STRANDED, LEADS CAN BE ANY COLOR EXCEPT GREEN OR GREEN WITH YELLOW STRIPE.
2. MOTOR IDENTIFICATION: MANUFACTURER'S NAME, MODEL NUMBER, VOLTAGE, FREQUENCY, INSPECTORS CODE, DATE OF MANUFACTURE, AGENCY RECOGNITION CODE, PLANT LOCATION CODE, PATENT INFORMATION * ONE OR MORE OF THE FOLLOWING PATENTS APPLY TO THIS MOTOR: 5482378; 5736805; 4669952; 4684835. * AND MADE IN THE USA.
3. ALLOW [0.0016 SQ IN]/2.5 SQ IN. FOR COOLING AIR INTAKE
4. COOLING AIR INTAKE MUST BE SEPERATED FROM COOLING AIR EXHAUST.
5. COOLING AIR EXHAUST MUST BE SEPERATED FROM VACUUM EXHAUST.
6. MOUNTING MUST NOT RESTRICT THIS DIAMETER.

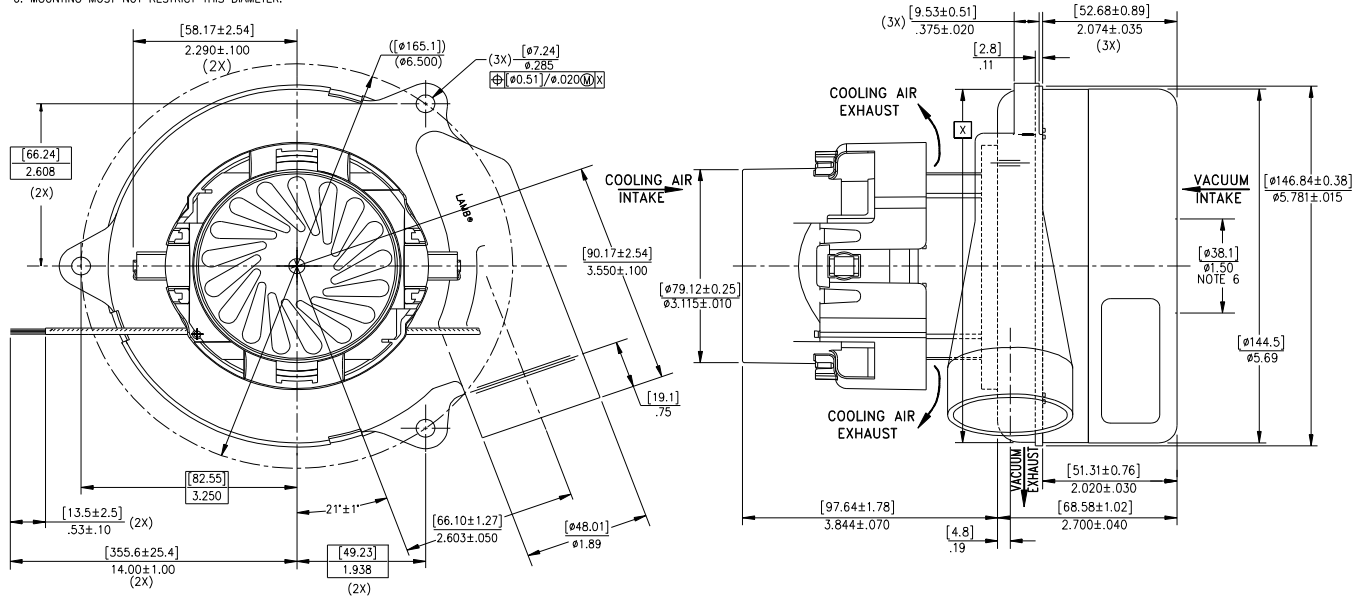

IMPORTANT NOTE: Pictorial and dimensional data are subject to change without notice. Contact factory for current revision levels.

WARNING - When using AMETEK Lamb Electric bypass motors in machines that come in contact with foam, liquid (including water), or other foreign substances, the machine must be designed and constructed to prevent those substances from reaching the fan system, motor housing, and electrical components. Lamb Electric vacuum motors other than hazardous duty models should not be applied in machines that come in contact with dry chemicals or other volatile materials. Failure to observe these precautions could cause flashing (depending on volatility) or electrical shock which could result in property damage and severe bodily injury, including death in extreme cases. All applications incorporating Lamb Electric motors should be submitted to appropriate organizations or agencies for testing specifically related to the safety of your equipment.

AMETEK/Lamb Electric Division
 627 Lake Street
 Kent, Ohio 44240
 U.S.A.
 Tel: (330) 673-3451
 Fax: (330) 673-8994

Ametek GmbH
 P. O. Box 1251
 D-71667 Marbach
 Germany
 Phone: + 49-714-484-9512
 Fax: + 49-714-484-9513

AMETEK/Singapore Private Limited
 10 Ang Mo Kio Street 65
 # 05-12 Techpoint
 Singapore 2056
 Tel: + 65-484-2388
 Fax: + 65-481-6588