



LAMB ELECTRIC



Model: 119411-00

DESCRIPTION

- One stage
- 120 volts
- 5.7"/145 mm diameter
- Ball/Ball bearings
- Single speed
- Thru-flow discharge
- Thermostat fan end bracket
- Thermostat commutator bracket

DESIGN APPLICATION

- Equipment operating in environments not requiring separation of working air from motor ventilating air
- Designed to handle clean, dry, filtered air only

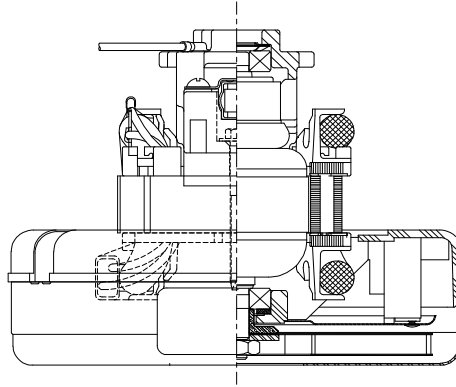

SPECIAL FEATURES

- Suitable for 120 volt AC operation, 50/60 Hz
- UL recognized, category PRGY2 (E47185)
- Provision for grounding
- Skeleton-frame design
- Thermal protection, automatic reset, UL category XEWR2 (E27701)
- The Lamb Electric vacuum motor line offers a wide range of performance levels to meet design needs.

Model 119411-00 is the G2K replacement for model 116455-50

TYPICAL MOTOR PERFORMANCE.*

(At 120 volts, 60Hz, test data is corrected to standard conditions of 29.92 Hg, 68° F.)

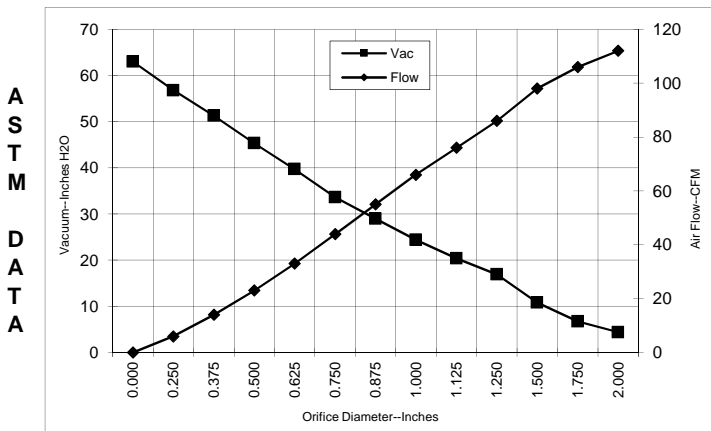

Orifice (Inches)	Amps	Watts (In)	RPM	Vac (In.H2O)	Flow (CFM)	Air Watts
2.000	6.6	788	20730	4.4	112.0	57
1.750	6.7	795	20500	6.7	106.0	84
1.500	6.7	797	20290	10.8	98.0	125
1.250	6.8	802	20430	16.9	86.0	170
1.125	6.7	790	20600	20.4	76.0	184
1.000	6.5	770	20930	24.4	66.0	190
0.875	6.3	746	21530	29.0	55.0	187
0.750	6.0	715	22280	33.6	44.0	172
0.625	5.7	640	25930	39.7	33.0	153
0.500	5.3	631	24490	45.3	23.0	120
0.375	4.9	586	25510	51.3	14.0	81
0.250	4.6	556	2689	56.8	6.0	42
0.000	4.4	554	26870	63.0	0.0	0

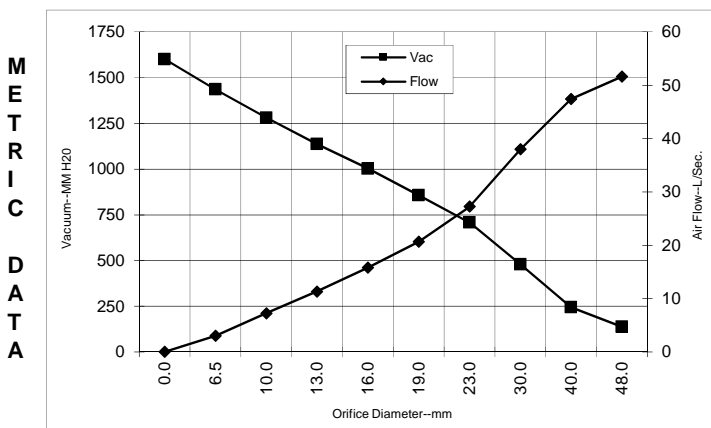

Orifice (mm)	Amps	Watts (In)	RPM	Vac (mm H2O)	Flow (L/Sec)	Air Watts
48.0	6.6	791	20629	137	51.6	69
40.0	6.7	796	20353	243	47.4	113
30.0	6.7	795	20524	478	38.0	178
23.0	6.4	752	21380	707	27.3	188
19.0	6.0	714	22353	857	20.7	172
16.0	5.7	643	25784	1002	15.8	154
13.0	5.3	632	24634	1136	11.3	123
10.0	5.0	593	25357	1280	7.2	87
6.5	4.6	558	3830	1436	3.0	44
0.0	4.4	554	26870	1600	0.0	0

Note: Metric performance data is calculated from the ASTM data above.

* Data represents performance of a typical motor sampled from a large production quantity. Individual motor data may vary due to normal manufacturing variations.

Test Specs:	120 volts	Minimum Sealed Vacuum:	56.0"	ORIFICE:	7/8 "	Minimum Vacuum:	26.0"	Maximum Watts:	850
--------------------	-----------	-------------------------------	-------	-----------------	-------	------------------------	-------	-----------------------	-----

DIMENSIONS



NOTES:

1. MOTOR IDENTIFICATION: MANUFACTURER'S NAME, MODEL NUMBER, VOLTAGE, FREQUENCY, INSPECTOR'S CODE, DATE OF MANUFACTURE, AGENCY RECOGNITION CODE, PLANT LOCATION CODE, AND MADE IN THE USA.
2. RECOMMENDED SCREW SIZE 10-16 TYPE BT OR TYPE 25 THREAD CUTTING SCREW. MAXIMUM PENETRATION [17.40]/.685.
3. GROUND LEAD: 18 GAUGE STRANDED; COLOR: GREEN WITH YELLOW STRIPE.

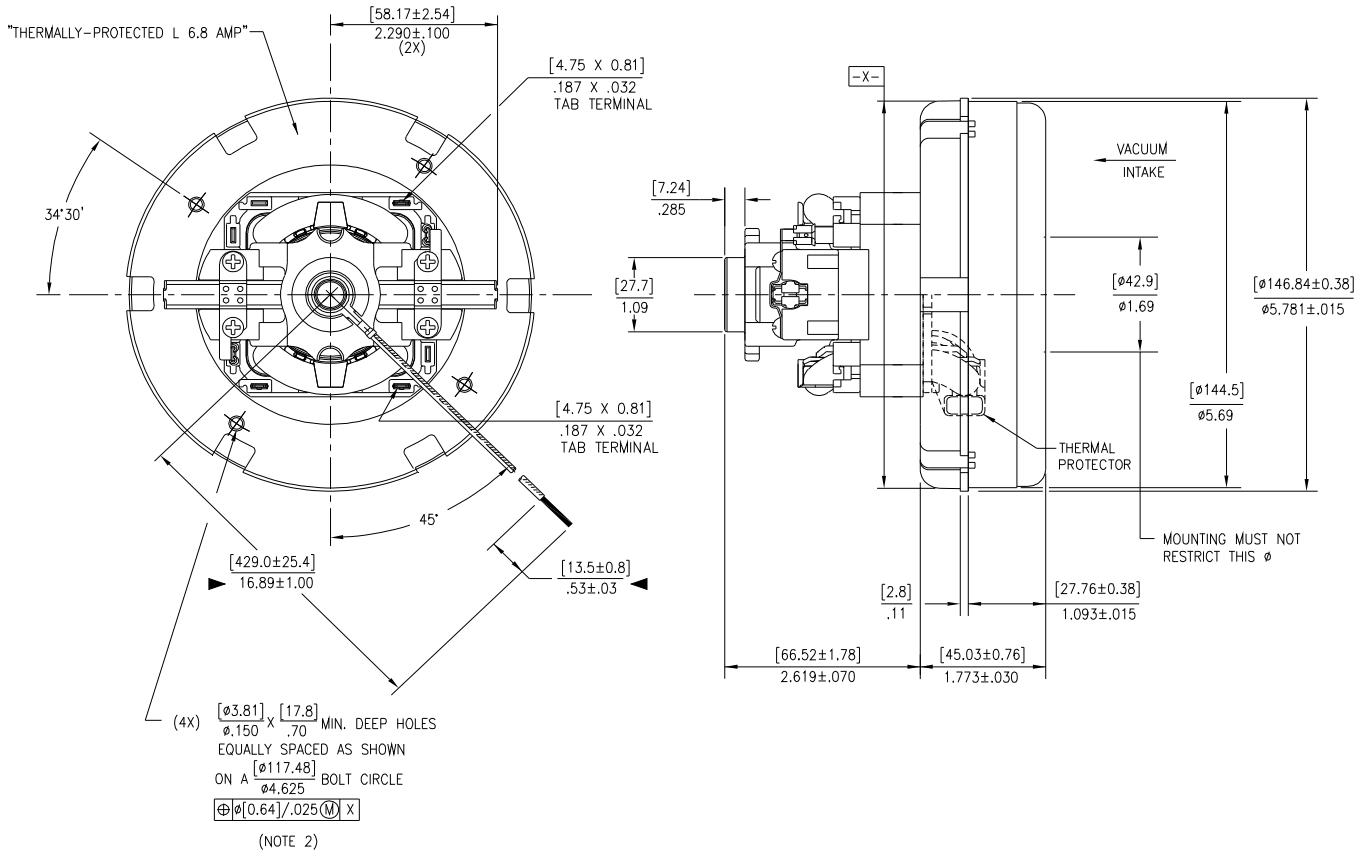

IMPORTANT NOTE: Pictorial and dimensional data are subject to change without notice. Contact factory for current revision levels.

WARNING - AMETEK Lamb Electric thru-flow vacuum motors must never be used in applications in which wet or moist conditions are involved, where dry chemicals or other volatile materials are present, or where airflow may be restricted or blocked. Such motors are designed to permit the vacuumed air to pass over the electrical winding to cool it. Thus any foam, liquid (including water), dry chemical, or other foreign substance coming in contact with electrical conductors could cause combustion (depending on volatility) or electrical shock. Failure to observe these precautions could result in property damage and severe personal injury, including death in extreme cases. All applications incorporating Lamb Electric motors should be submitted to Underwriters Laboratories Inc. or other appropriate organizations or agencies for testing specifically related to the safety of your equipment.

AMETEK/Floorcare & Specialty Motors
www.ametekfsm.com