



DESCRIPTION

- Two stage
- 120 volts
- 4.8"/122 mm diameter
- Ball/sleeve bearing construction
- Single speed
- Peripheral bypass discharge
- Aluminum fan end bracket
- Aluminum commutator bracket

DESIGN APPLICATION

- Equipment operating in environments requiring separation of working air from motor ventilating air
- Designed to handle clean, dry, filtered air only

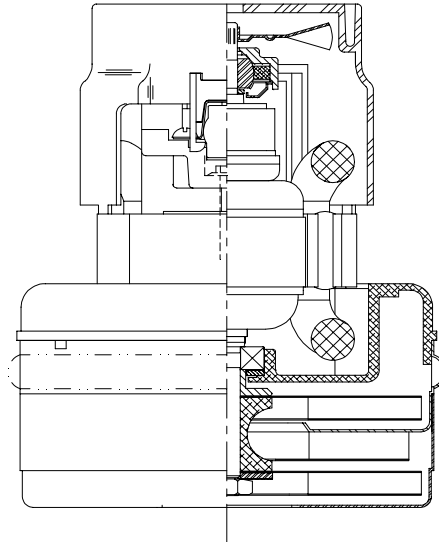

SPECIAL FEATURES

- Suitable for 120 volt operation, 50/60 Hz
- UL recognized, category PRGY2 (E47185)
- CSA Certified, class 1611 01 (LR31393)
- Provision for grounding
- Skeleton frame design
- The Lamb vacuum motor line offers a wide range of performance levels to meet design needs
- Same as 116551-50 except has class B insulation (7AM thermostat (110°C))

TYPICAL MOTOR PERFORMANCE.*

(At 120 volts, 60Hz, test data is corrected to standard conditions of 29.92 Hg, 68° F.)

ASTM DATA

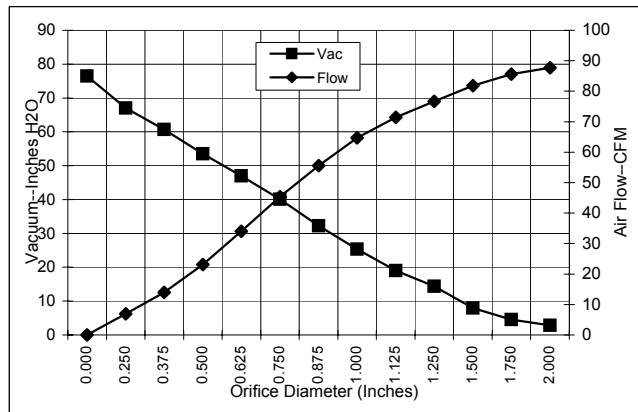

Orifice (Inches)	Amps	Watts (In)	RPM	Vac (In.H ₂ O)	Flow (CFM)	Air Watts
2.000	6.9	781	19390	2.8	87.7	29
1.750	6.8	770	19140	4.6	85.6	46
1.500	6.9	786	19180	7.9	81.8	76
1.250	6.9	789	19140	14.4	76.7	130
1.125	6.9	786	19115	19.0	71.4	160
1.000	6.9	783	19225	25.3	64.7	193
0.875	6.7	765	19405	32.2	55.6	211
0.750	6.6	747	19990	40.1	45.4	214
0.625	6.1	701	20685	47.0	34.0	188
0.500	5.7	654	21625	53.5	23.1	145
0.375	5.2	604	22755	60.7	14.0	100
0.250	4.8	558	23785	67.0	6.9	54
0.000	4.5	524	24770	76.5	0.0	0

METRIC DATA

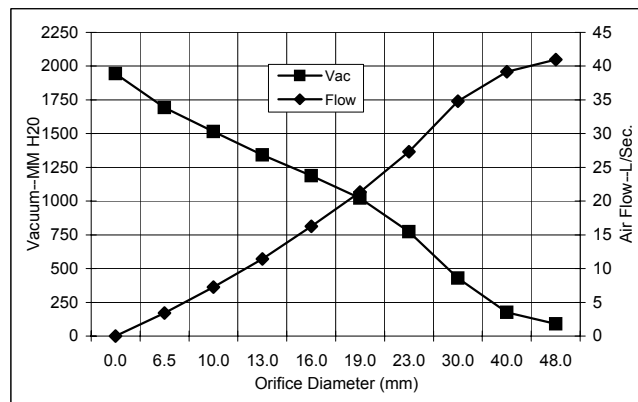

Orifice (mm)	Amps	Watts (In)	RPM	Vac (mm H ₂ O)	Flow (L/Sec)	Air Watts
48.0	6.8	776	19280	91	41.0	36
40.0	6.9	781	19168	175	39.1	67
30.0	6.9	787	19126	430	34.8	147
23.0	6.8	770	19360	774	27.3	207
19.0	6.5	746	20004	1022	21.3	213
16.0	6.1	703	20657	1187	16.3	189
13.0	5.7	659	21531	1342	11.4	149
10.0	5.3	612	22586	1514	7.3	107
6.5	4.9	560	23734	1694	3.4	56
0.0	4.5	524	24770	1943	0.0	0

Note: Metric performance data is calculated from the ASTM data above.

* Data represents performance of a typical motor sampled from a large production quantity. Individual motor data may vary to normal manufacturing variations.

Test Specs:	120 volts	Minimum Sealed Vacuum:	65.0"	ORIFICE:	7/8"	Minimum Vacuum:	30.0"	Maximum Watts:	870
--------------------	-----------	-------------------------------	-------	-----------------	------	------------------------	-------	-----------------------	-----

DIMENSIONS

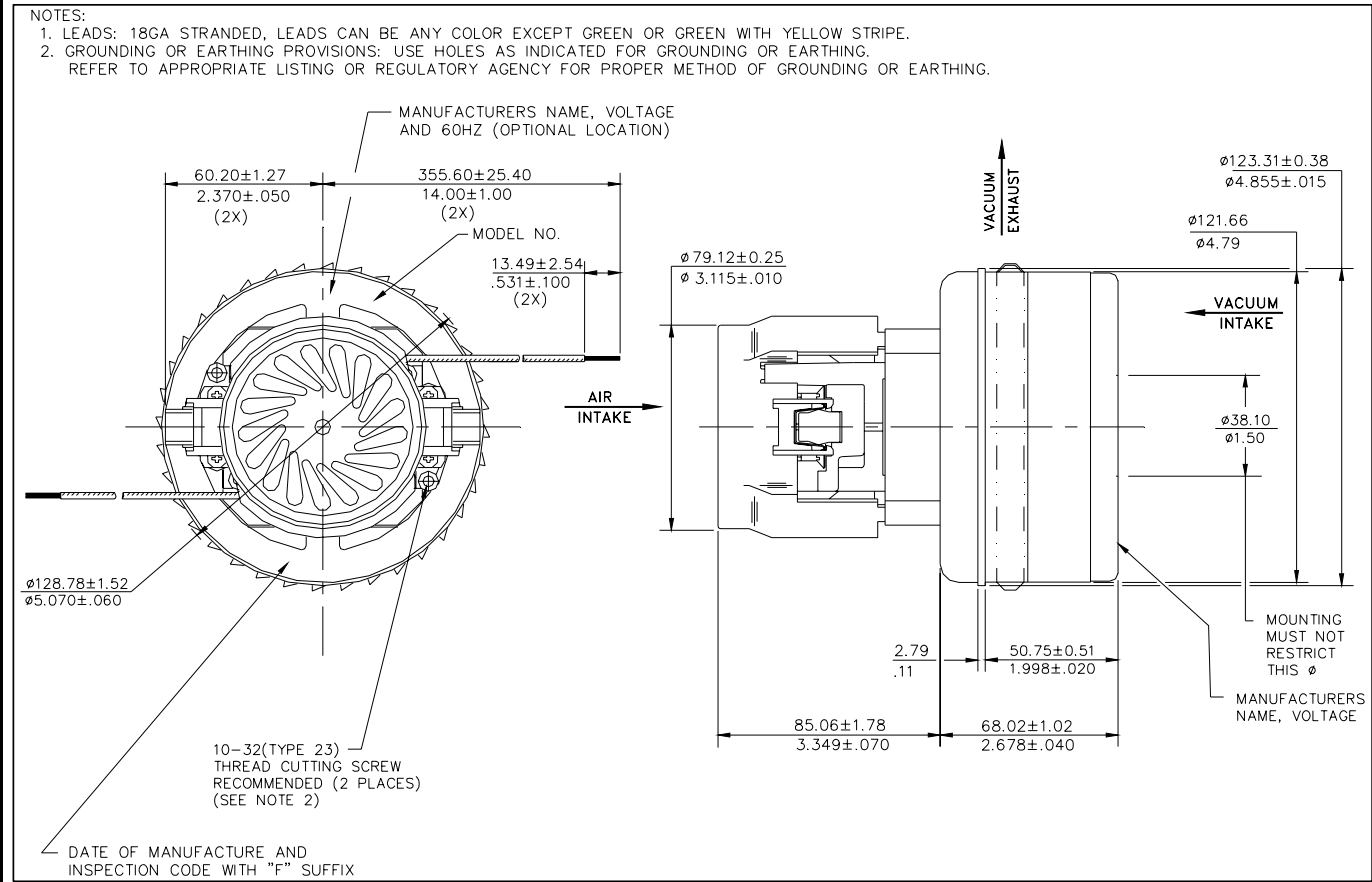

IMPORTANT NOTE: Pictorial and dimensional data are subject to change without notice. Contact factory for current revision levels.

WARNING - When using AMETEK/Lamb Electric bypass motors in machines that come in contact with foam, liquid (including water) or other foreign substances, the machine must be designed and constructed to prevent those substances from reaching the fan system, motor housing and electrical components. Lamb vacuum motors other than hazardous duty models should not be applied in machines that come in contact with dry chemicals or other volatile materials. Failure to observe these precautions could cause flashing (depending on volatility) or electrical shock which could result in property damage and severe bodily injury, including death in extreme cases. All applications incorporating Lamb motors should be submitted to appropriate organizations or agencies for testing specifically related to the safety of your equipment.

AMETEK/Lamb Electric Division
 627 Lake Street
 Kent, Ohio 44240
 U.S.A.
 Tel: (330) 673-3451 Fax: (330) 673-8994
 www.lambelectric.com