



**AMETEK**

**LAMB ELECTRIC**

**Product Bulletin**

**Model: 117511-00  
117511-13\***

**DESCRIPTION**

- Three stage
- 120 volts
- 7.2"/183 mm diameter
- Double ball bearing construction
- Single speed
- Peripheral bypass discharge
- Thermoset fan end bracket
- Thermoset commutator bracket

**DESIGN APPLICATION**

- Equipment operating in environments requiring separation of working air from motor ventilating air
- Designed to handle clean, dry, filtered air only

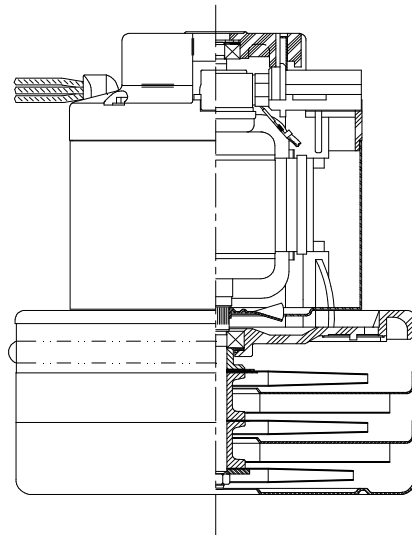

**SPECIAL FEATURES**

- Suitable for 120 volt operation, 50 or 60 Hz
- UL Recognized, category PRGY2, (E47185)
- CSA Certified, class 1611 01 (LR31393)
- 10 mm shaft and bearing system
- Provision for grounding
- The Lamb vacuum motor line offers a wide range of performance levels to meet design needs

**\*Model 117511-13 features Patented air seal bearing construction. U.S. Patent #4,088,424 and epoxy painted fan case**

**TYPICAL MOTOR PERFORMANCE.\***

(At 120 volts, 60Hz, test data is corrected to standard conditions of 29.92 Hg, 68° F.)

**ASTM DATA**

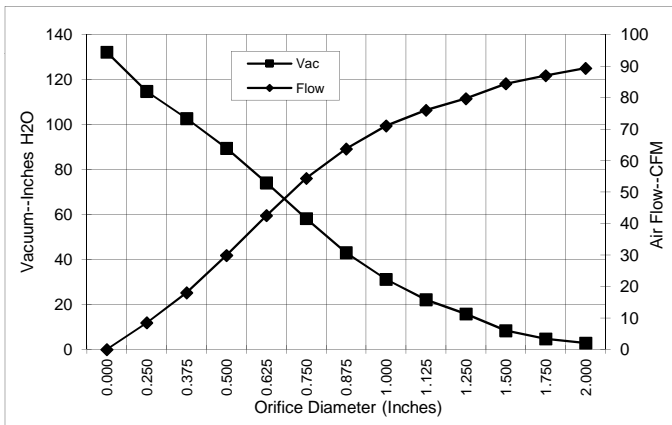

Orifice (Inches)	Amps	Watts (In)	RPM	Vac (In.H <sub>2</sub> O)	Flow (CFM)	Air Watts
2.000	11.5	1286	18000	2.9	89.3	30
1.750	11.5	1283	17950	4.8	87.0	49
1.500	11.5	1285	17890	8.4	84.4	84
1.250	11.5	1289	17830	15.9	79.7	149
1.125	11.6	1300	17820	22.2	76.0	198
1.000	11.6	1304	17780	31.2	71.1	261
0.875	11.6	1296	17760	43.1	63.7	323
0.750	11.6	1294	17780	58.3	54.4	373
0.625	11.3	1263	18070	74.2	42.6	371
0.500	10.6	1196	18670	89.5	29.9	315
0.375	9.8	1104	19600	102.7	18.0	218
0.250	8.9	1011	20740	114.8	8.5	115
0.000	8.1	928	22040	132.3	0.0	0

**METRIC DATA**

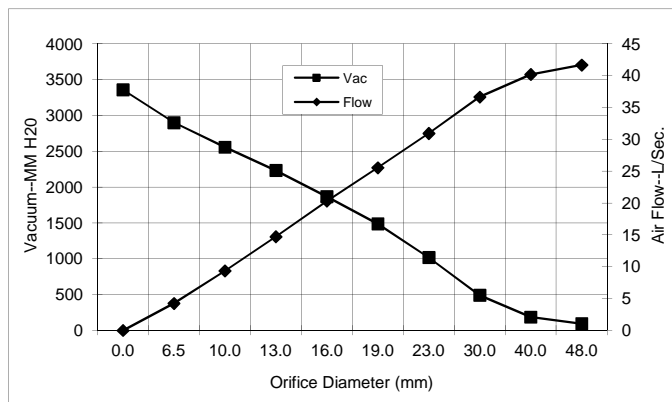

Orifice (mm)	Amps	Watts (In)	RPM	Vac (mm H <sub>2</sub> O)	Flow (L/Sec)	Air Watts
48.0	11.5	1285	17978	94	41.7	39
40.0	11.5	1284	17908	186	40.2	73
30.0	11.6	1295	17825	491	36.7	176
23.0	11.6	1298	17765	1019	30.9	307
19.0	11.6	1293	17786	1488	25.6	373
16.0	11.3	1264	18058	1868	20.3	371
13.0	10.7	1203	18610	2234	14.7	321
10.0	9.9	1118	19461	2559	9.4	233
6.5	8.9	1016	20683	2901	4.2	120
0.0	8.1	928	22040	3359	0.0	0

Note: Metric performance data is calculated from the ASTM data above.

\* Data represents performance of a typical motor sampled from a large production quantity. Individual motor data may vary to normal manufacturing variations.

<b>Test Specs:</b>	120 volts	<b>Minimum Sealed Vacuum:</b>	127"	<b>ORIFICE:</b>	7/8"	<b>Minimum Vacuum:</b>	42.0	<b>Maximum Watts:</b>	1475
--------------------	-----------	-------------------------------	------	-----------------	------	------------------------	------	-----------------------	------

**DIMENSIONS**

NOTES:

1. LEADS: 16GA. STRANDED, ONE BLACK AND ONE WHITE. GROUND LEAD: 18GA. STRANDED; COLOR GREEN WITH YELLOW STRIPE.

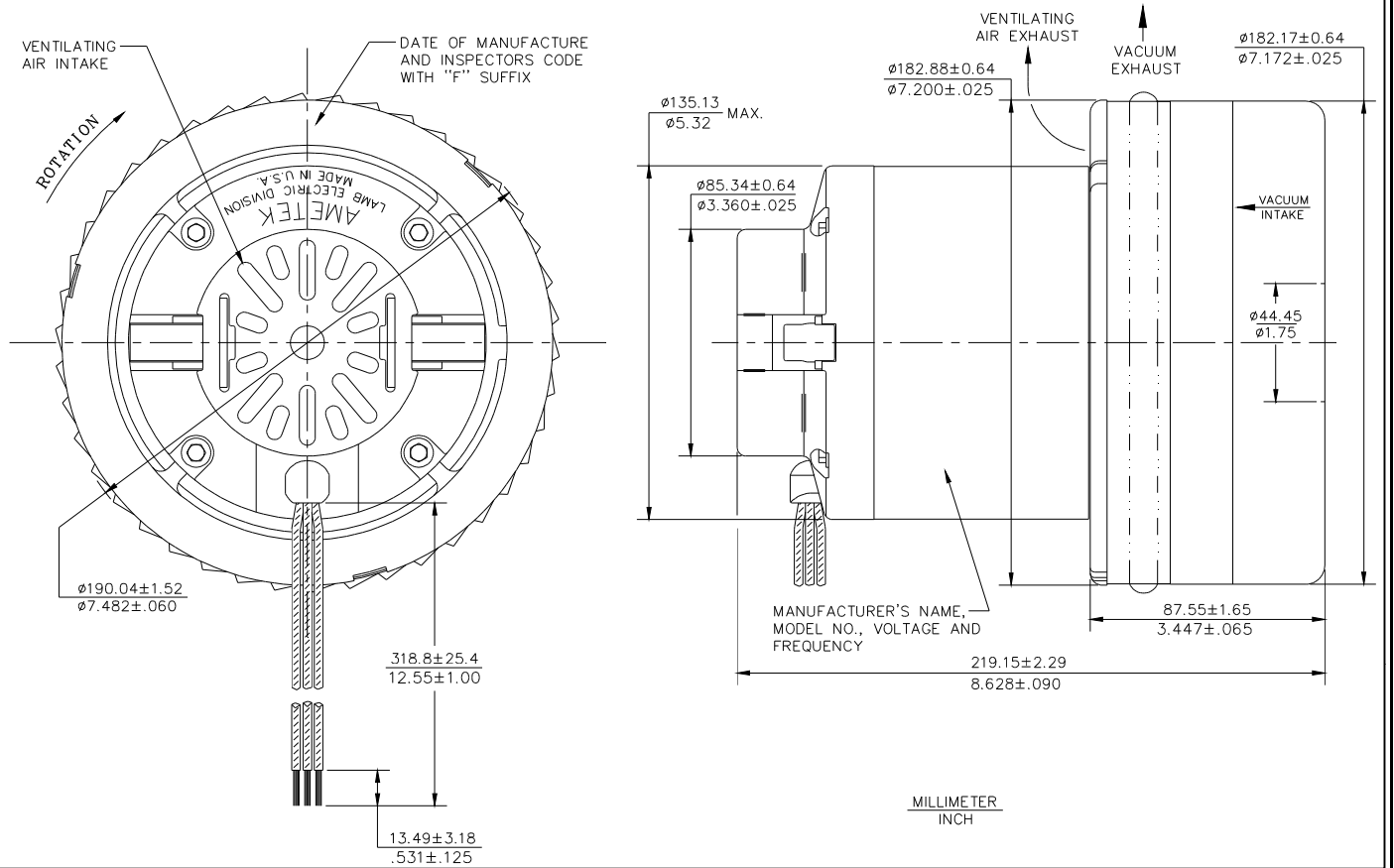

**IMPORTANT NOTE:** Pictorial and dimensional data are subject to change without notice. Contact factory for current revision levels.

**WARNING** - When using AMETEK/Lamb Electric bypass motors in machines that come in contact with foam, liquid (including water) or other foreign substances, the machine must be designed and constructed to prevent those substances from reaching the fan system, motor housing and electrical components. Lamb vacuum motors other than hazardous duty models should not be applied in machines that come in contact with dry chemicals or other volatile materials. Failure to observe these precautions could cause flashing (depending on volatility) or electrical shock which could result in property damage and severe bodily injury, including death in extreme cases. All applications incorporating Lamb motors should be submitted to appropriate organizations or agencies for testing specifically related to the safety of your equipment.

**AMETEK/Floorcare & Specialty Motors**  
[www.ametekfsm.com](http://www.ametekfsm.com)