



**Model: 117478-12**

**DESCRIPTION**

- Two stage
- 120 volts
- 7.2"/183 mm diameter
- Double ball bearings
- Single speed
- Tangential bypass discharge
- Aluminum fan end bracket
- Aluminum commutator bracket

**DESIGN APPLICATION**

- Equipment operating in environments requiring separation of working air from motor ventilating air
- Designed to handle clean, dry, filtered air only

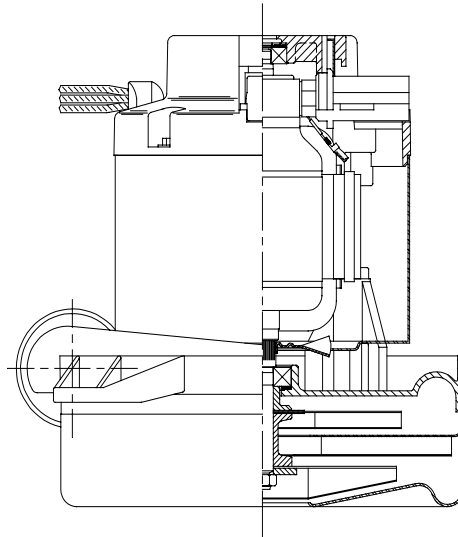

**SPECIAL FEATURES**

- Suitable for 120 volt AC operation, 50/60 Hz
- UL recognized, category PRGY2 (E47185)
- CSA certified, class 1611 01 (LR31393)
- Provision for grounding
- 10 mm shaft and bearing system
- Epoxy painted fan case
- Aluminum fan-end bracket designed to dampen vibration and improve durability
- The Lamb Electric vacuum motor line offers a wide range of performance levels to meet design needs

**TYPICAL MOTOR PERFORMANCE.\***

(At 120 volts, 60Hz, test data is corrected to standard conditions of 29.92 Hg, 68° F.)

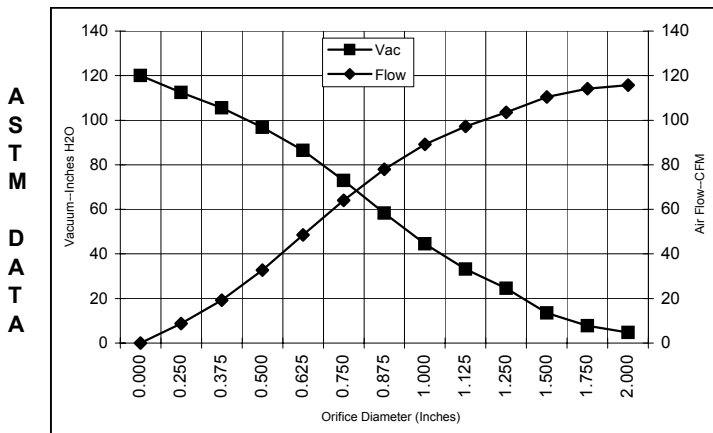

| Orifice (Inches) | Amps | Watts (In) | RPM   | Vac (In.H2O) | Flow (CFM) | Air Watts |
|------------------|------|------------|-------|--------------|------------|-----------|
| 2.000            | 13.8 | 1572       | 22310 | 4.7          | 115.8      | 64        |
| 1.750            | 13.8 | 1572       | 22310 | 7.8          | 114.2      | 105       |
| 1.500            | 13.9 | 1583       | 22235 | 13.5         | 110.4      | 175       |
| 1.250            | 14.0 | 1595       | 22140 | 24.6         | 103.5      | 299       |
| 1.125            | 14.0 | 1591       | 22150 | 33.1         | 97.2       | 378       |
| 1.000            | 14.0 | 1593       | 22135 | 44.5         | 89.1       | 465       |
| 0.875            | 13.9 | 1581       | 22285 | 58.3         | 78.0       | 534       |
| 0.750            | 13.5 | 1544       | 22550 | 72.9         | 64.1       | 549       |
| 0.625            | 12.9 | 1473       | 23095 | 86.4         | 48.5       | 492       |
| 0.500            | 11.9 | 1371       | 23970 | 96.8         | 32.8       | 373       |
| 0.375            | 10.9 | 1261       | 25050 | 105.5        | 19.3       | 239       |
| 0.250            | 10.2 | 1179       | 26015 | 112.5        | 8.8        | 116       |
| 0.000            | 9.7  | 1115       | 26745 | 120.0        | 0.0        | 0         |

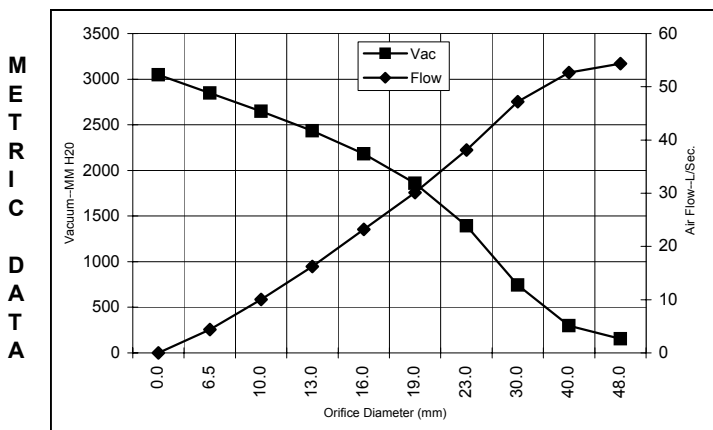

| Orifice (mm) | Amps | Watts (In) | RPM   | Vac (mm H2O) | Flow (L/Sec) | Air Watts |
|--------------|------|------------|-------|--------------|--------------|-----------|
| 48.0         | 13.8 | 1572       | 22310 | 154          | 54.3         | 82        |
| 40.0         | 13.9 | 1580       | 22258 | 299          | 52.6         | 154       |
| 30.0         | 14.0 | 1593       | 22146 | 744          | 47.2         | 342       |
| 23.0         | 13.9 | 1584       | 22248 | 1393         | 38.1         | 517       |
| 19.0         | 13.5 | 1543       | 22561 | 1859         | 30.1         | 548       |
| 16.0         | 12.9 | 1476       | 23073 | 2181         | 23.2         | 494       |
| 13.0         | 12.0 | 1381       | 23883 | 2432         | 16.2         | 385       |
| 10.0         | 11.1 | 1278       | 24888 | 2647         | 10.1         | 259       |
| 6.5          | 10.2 | 1183       | 25967 | 2849         | 4.4          | 122       |
| 0.0          | 9.7  | 1115       | 26745 | 3048         | 0.0          | 0         |

Note: Metric Performance data is calculated from the ASTM data above.

\* Data represents performance of a typical motor sampled from a large production quantity. Individual motor data may vary due to normal manufacturing variations.

|                    |           |                               |        |                 |      |                        |       |                       |      |
|--------------------|-----------|-------------------------------|--------|-----------------|------|------------------------|-------|-----------------------|------|
| <b>Test Specs:</b> | 120 volts | <b>Minimum Sealed Vacuum:</b> | 120.0" | <b>ORIFICE:</b> | 7/8" | <b>Minimum Vacuum:</b> | 55.0" | <b>Maximum Watts:</b> | 1700 |
|--------------------|-----------|-------------------------------|--------|-----------------|------|------------------------|-------|-----------------------|------|

**DIMENSIONS**

NOTES:

1. LEADS: 16GA. STRANDED, ONE BLACK AND ONE WHITE. GROUND LEAD: 18GA. STRANDED, GREEN WITH YELLOW STRIPE.

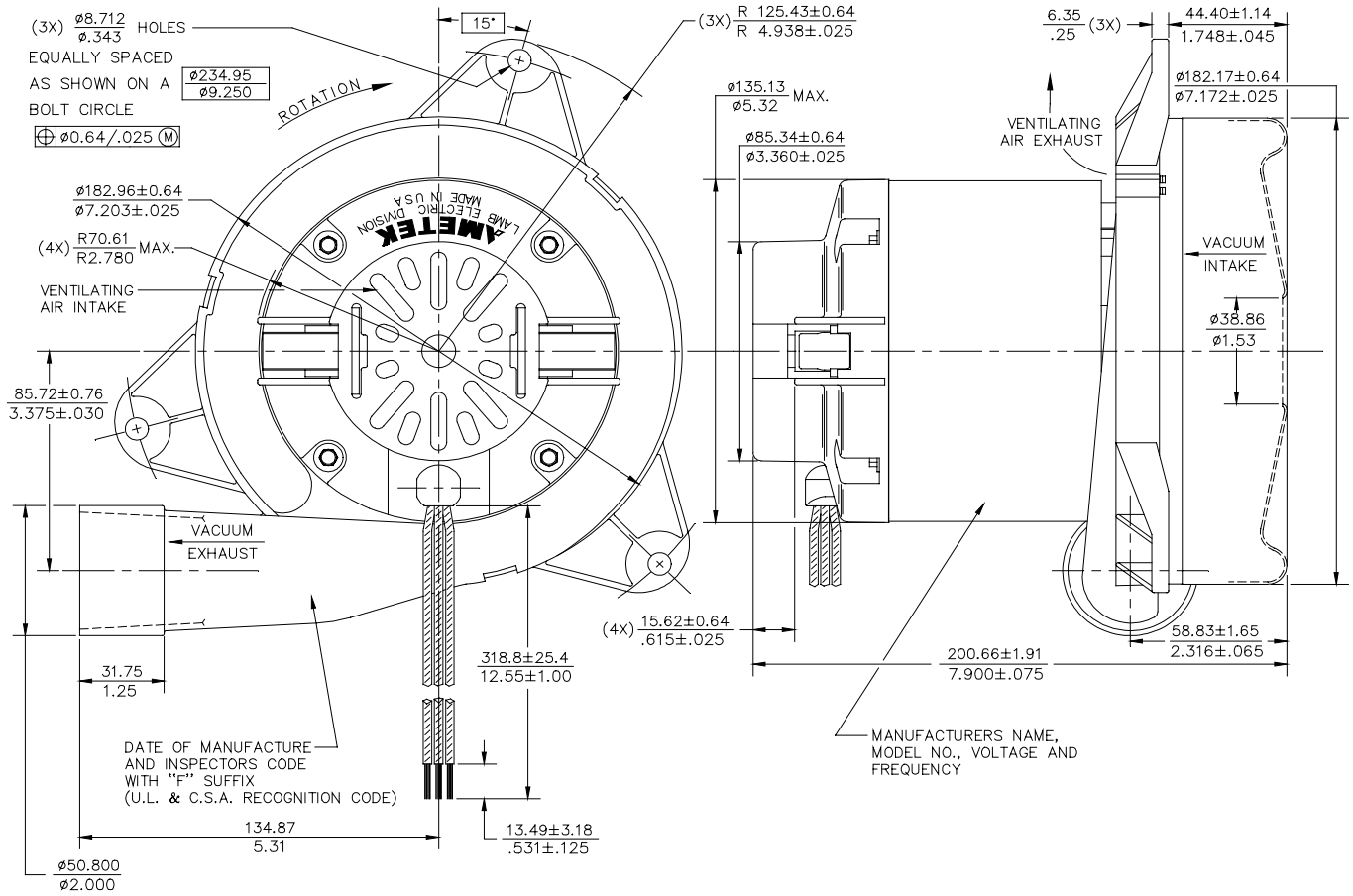

**IMPORTANT NOTE:** Pictorial and dimensional data are subject to change without notice. Contact factory for current revision levels.

**WARNING** - When using AMETEK Lamb Electric bypass motors in machines that come in contact with foam, liquid (including water), or other foreign substances, the machine must be designed and constructed to prevent those substances from reaching the fan system, motor housing, and electrical components. Lamb Electric vacuum motors other than hazardous duty models should not be applied in machines that come in contact with dry chemicals or other volatile materials. Failure to observe these precautions could cause flashing (depending on volatility) or electrical shock which could result in property damage and severe bodily injury, including death in extreme cases. All applications incorporating Lamb Electric motors should be submitted to appropriate organizations or agencies for testing specifically related to the safety of your equipment.

**AMETEK/Lamb Electric Division**  
 627 Lake Street  
 Kent, Ohio 44240  
 U.S.A.  
 Tel: (330) 673-3451  
 Fax: (330) 673-8994

**Ametek GmbH**  
 P. O. Box 1251  
 D-71667 Marbach  
 Germany  
 Phone: + 49-714-484-9512  
 Fax: + 49-714-484-9513

**AMETEK/Singapore Private Limited**  
 10 Ang Mo Kio Street 65  
 # 05-12 Techpoint  
 Singapore 2056  
 Tel: + 65-484-2388  
 Fax: + 65-481-6588