



LAMB ELECTRIC

Model: 117403-13

DESCRIPTION

- One stage
- 240 volts
- 5.7"/145 mm diameter
- Ball/Ball bearings
- Single speed
- Tangential bypass discharge
- Thermoset fan end bracket
- Aluminum commutator bracket

DESIGN APPLICATION

- Equipment operating in environments requiring separation of working air from motor ventilating air
- Designed to handle clean, dry, filtered air only

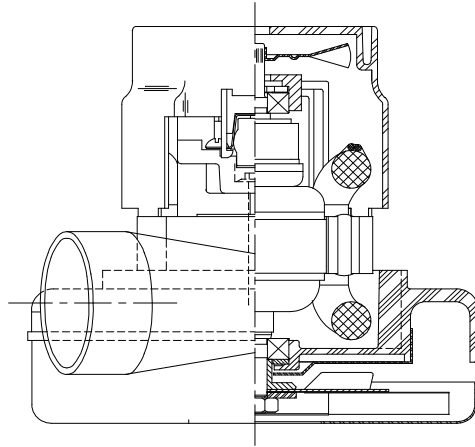

SPECIAL FEATURES

- Suitable for 240 volt AC operation, 50/60 Hz
- UL recognized, category PRGY2 (E47185)
- Skeleton-frame design
- Provision for grounding
- The Lamb Electric vacuum motor line offers a wide range of performance levels to meet design needs
- Patented air seal bearing construction.

TYPICAL MOTOR PERFORMANCE.*

(At 240 volts, 60Hz, test data is corrected to standard conditions of 29.92 Hg, 68° F.)

ASTM DATA

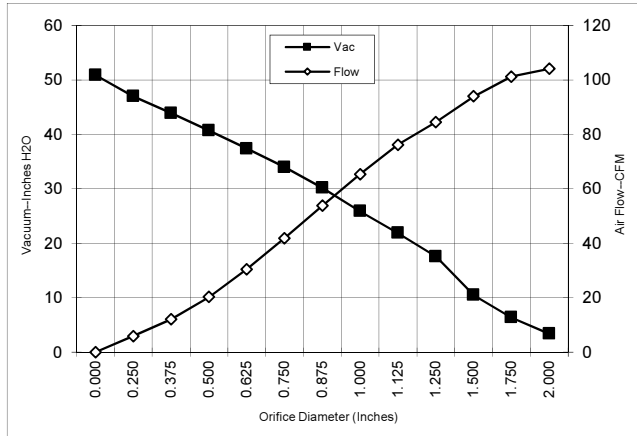

Orifice (Inches)	Amps	Watts (In)	RPM	Vac (In.H2O)	Flow (CFM)	Air Watts
2.000	3.1	692	19155	3.4	104.1	49
1.750	3.1	697	19075	6.4	101.2	77
1.500	3.1	702	18978	10.5	94.0	117
1.250	3.1	706	18838	17.6	84.5	175
1.125	3.1	702	18920	21.9	76.2	196
1.000	3.1	689	19187	25.9	65.4	199
0.875	3.0	673	19502	30.2	53.8	191
0.750	2.9	645	19662	34.0	41.9	167
0.625	2.7	617	20549	37.4	30.5	134
0.500	2.6	585	21290	40.7	20.3	97
0.375	2.4	554	21927	43.9	12.1	62
0.250	2.3	530	22563	47.0	5.9	33
0.000	2.2	507	23080	50.9	0.0	0

METRIC DATA

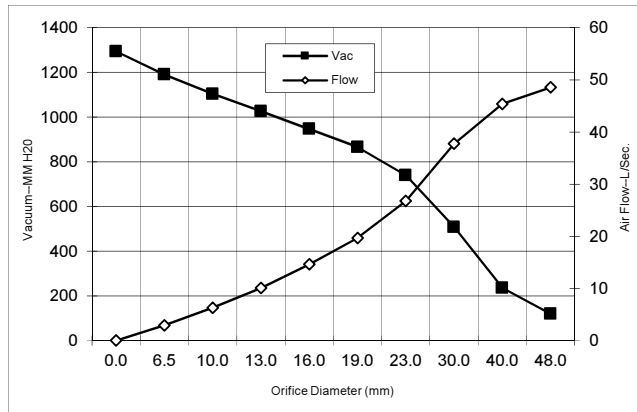

Orifice (mm)	Amps	Watts (In)	RPM	Vac (mm H2O)	Flow (L/Sec)	Air Watts
48.0	3.1	694	19120	120	48.5	61
40.0	3.1	701	19007	235	45.4	105
30.0	3.1	704	18883	507	37.7	187
23.0	3.0	677	19423	740	26.8	193
19.0	2.9	644	19680	865	19.7	166
16.0	2.7	618	20514	947	14.6	135
13.0	2.6	588	21216	1025	10.1	101
10.0	2.4	559	21831	1103	6.3	67
6.5	2.3	531	22531	1190	2.9	34
0.0	2.2	507	23080	1293	0.0	0

Note: Metric performance data is calculated from the ASTM data above.

* Data represents performance of a typical motor sampled from a large production quantity. Individual motor data may vary due to normal manufacturing variations.

Test Specs:	120 volts	Minimum Sealed Vacuum:	48.0"	ORIFICE:	7/8"	Minimum Vacuum:	37.0"	Maximum Watts:	750
--------------------	-----------	-------------------------------	-------	-----------------	------	------------------------	-------	-----------------------	-----

DIMENSIONS

NOTES:
 1. LEADS: 18GA STRANDED, LEADS CAN BE ANY COLOR EXCEPT GREEN OR GREEN WITH YELLOW STRIPE.

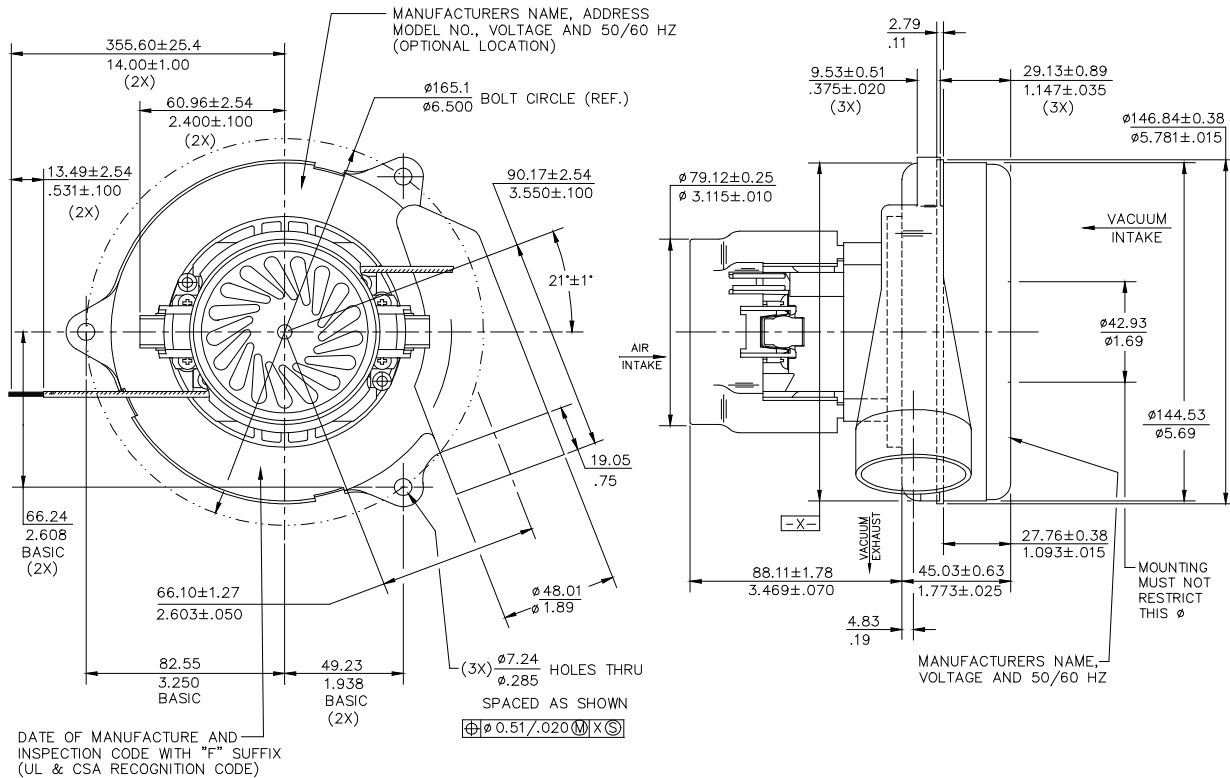

IMPORTANT NOTE: Pictorial and dimensional data are subject to change without notice. Contact factory for current revision levels.

WARNING - When using AMETEK Lamb Electric bypass motors in machines that come in contact with foam, liquid (including water), or other foreign substances, the machine must be designed and constructed to prevent those substances from reaching the fan system, motor housing, and electrical components. Lamb Electric vacuum motor other than hazardous duty models should not be applied in machines that come in contact with dry chemicals or other volatile materials. Failure to observe these precautions could cause flashing (depending on volatility) or electrical shock which could result in property damage and severe bodily injury, including death in extreme cases. All applications incorporating Lamb Electric motors should be submitted to appropriate organizations or agencies for testing specifically related to the safety of your equipment.

AMETEK Dynamic Fluid Solutions
www.ametekdfs.com