



Model: 117227-00

DESCRIPTION

- Three stage
- 36 volts
- 7.5"/191 mm diameter
- Double ball bearings
- Single speed
- Peripheral bypass discharge
- Aluminum fan end bracket
- Aluminum commutator bracket

DESIGN APPLICATION

- Equipment operating in environments requiring separation of working air from motor ventilating air
- Designed to handle clean, dry, filtered air only

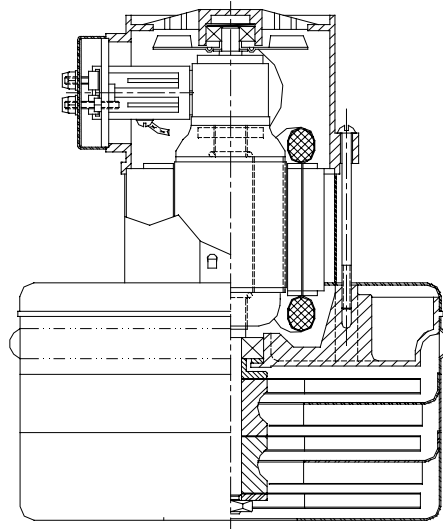

SPECIAL FEATURES

- Suitable for 36 volt DC operation
- UL recognized, category PRGY2 (E47185)
- Provision for grounding
- Compound brush system
- Heavy duty construction
- The Lamb Electric vacuum motor line offers a wide range of performance levels to meet design needs

TYPICAL MOTOR PERFORMANCE.*

(At 36 volts DC, test data is corrected to standard conditions of 29.92 Hg, 68° F.)

ASTM DATA

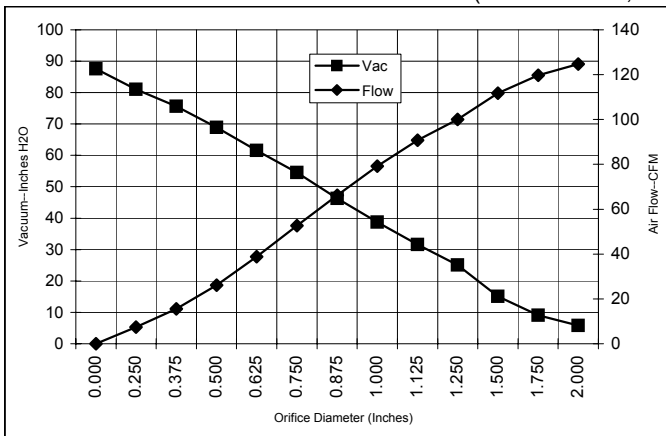

Orifice (Inches)	Amps	Watts (In)	RPM	Vac (In.H ₂ O)	Flow (CFM)	Air Watts
2.000	32.9	1184	11420	5.8	124.8	85
1.750	33.1	1191	11340	9.1	119.8	129
1.500	33.4	1204	11260	15.1	111.7	198
1.250	33.9	1219	11195	25.1	100.1	295
1.125	33.9	1219	11197	31.6	90.7	336
1.000	33.4	1203	11287	38.7	79.2	361
0.875	32.4	1168	11720	46.3	66.2	360
0.750	30.8	1108	12005	54.5	52.7	338
0.625	29.1	1047	12412	61.6	38.8	281
0.500	27.0	973	12917	68.9	26.1	211
0.375	24.8	894	13330	75.6	15.5	138
0.250	23.1	830	13962	81.0	7.4	70
0.000	21.6	780	14497	87.6	0.0	0

METRIC DATA

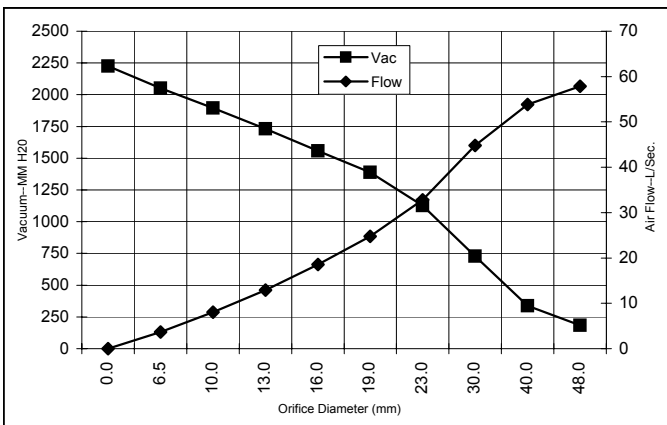

Orifice (mm)	Amps	Watts (In)	RPM	Vac (mm H ₂ O)	Flow (L/Sec)	Air Watts
48.0	33.0	1187	11385	184	57.9	104
40.0	33.3	1200	11284	338	53.9	177
30.0	33.9	1219	11196	728	44.8	318
23.0	32.7	1177	11612	1128	32.8	360
19.0	30.7	1107	12013	1388	24.7	337
16.0	29.1	1049	12396	1557	18.6	283
13.0	27.2	980	12867	1732	12.9	218
10.0	25.2	906	13268	1895	8.1	149
6.5	23.1	833	13930	2051	3.7	73
0.0	21.6	780	14497	2225	0.0	0

Note: Metric performance data is calculated from the ASTM data above.

* Data represents performance of a typical motor sampled from a large production quantity. Individual motor data may vary due to normal manufacturing variations.

Test Specs:	36 volts	Minimum Sealed Vacuum:	70.0"	ORIFICE:	7/8 "	Minimum Vacuum:	40.0"	Maximum Watts:	1292
--------------------	-----------------	-------------------------------	--------------	-----------------	--------------	------------------------	--------------	-----------------------	-------------

DIMENSIONS

NOTES:

1. GROUNDING OR EARTHING PROVISIONS: USE HOLES AS INDICATED FOR GROUNDING OR EARTHING. REFER TO APPROPRIATE LISTING OR REGULATORY AGENCY FOR PROPER METHOD OF GROUNDING OR EARTHING.

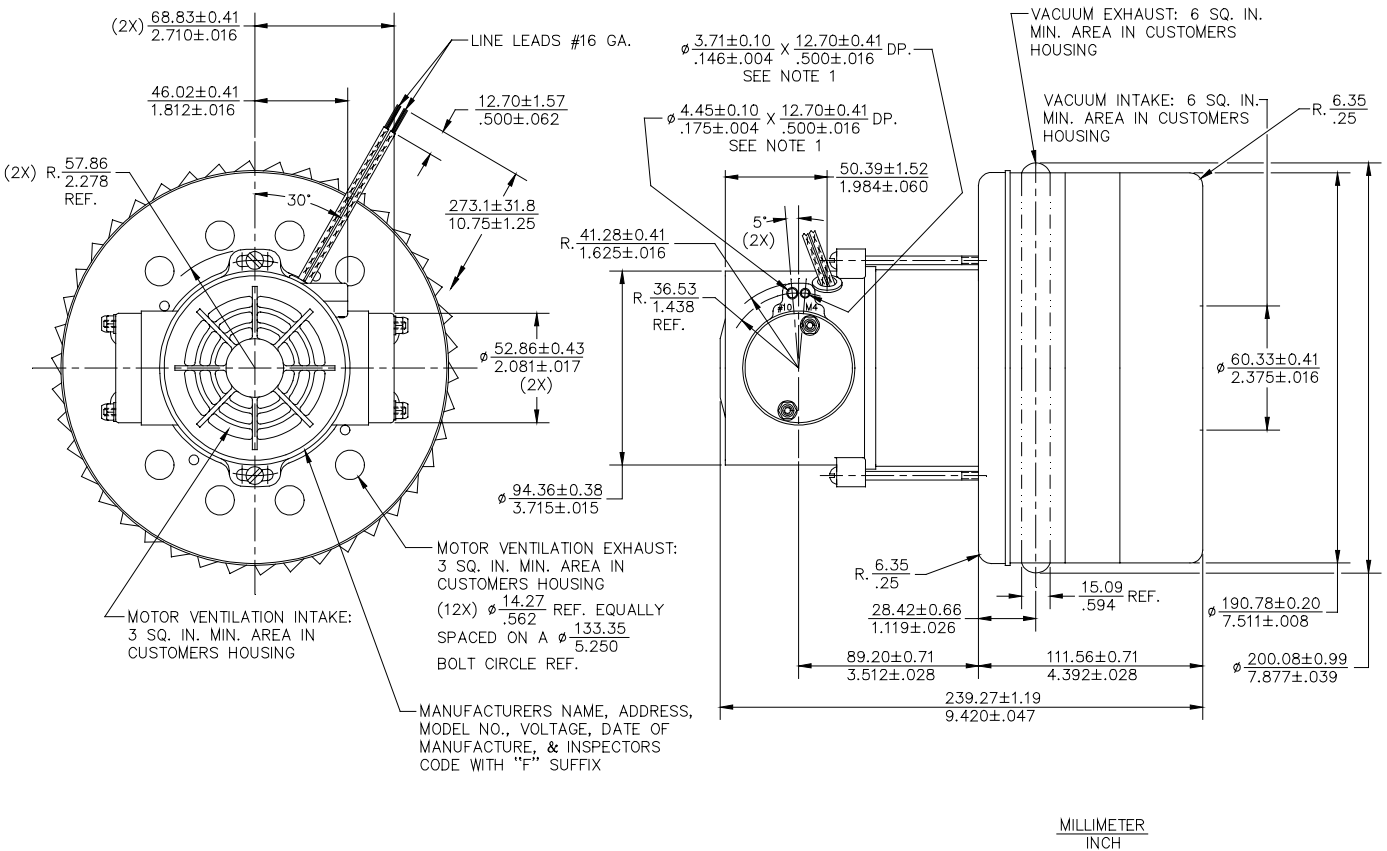

IMPORTANT NOTE: Pictorial and dimensional data are subject to change without notice. Contact factory for current revision levels.

WARNING - When using AMETEK Lamb Electric bypass motors in machines that come in contact with foam, liquid (including water), or other foreign substances, the machine must be designed and constructed to prevent those substances from reaching the fan system, motor housing, and electrical components. Lamb Electric vacuum motors other than hazardous duty models should not be applied in machines that come in contact with dry chemicals or other volatile materials. Failure to observe these precautions could cause flashing (depending on volatility) or electrical shock which could result in property damage and severe bodily injury, including death in extreme cases. All applications incorporating Lamb Electric motors should be submitted to appropriate organizations or agencies for testing specifically related to the safety of your equipment.

AMETEK/Lamb Electric Division
 627 Lake Street
 Kent, Ohio 44240
 U.S.A.
 Tel: (330) 673-3451
 Fax: (330) 673-8994

Ametek GmbH
 P. O. Box 1251
 D-71667 Marbach
 Germany
 Phone: + 49-714-484-9512
 Fax: + 49-714-484-9513

AMETEK/Singapore Private Limited
 10 Ang Mo Kio Street 65
 # 05-12 Techpoint
 Singapore 2056
 Tel: + 65-484-2388
 Fax: + 65-481-6588