



DESCRIPTION

- Two stage
- 120 volts
- 5.7"/145 mm diameter
- Double ball bearings
- Single speed
- Tangential bypass discharge
- Plastic fan end bracket
- Aluminum commutator bracket

DESIGN APPLICATION

- Equipment operating in environments requiring separation of working air from motor ventilating air
- Designed to handle clean, dry, filtered air only

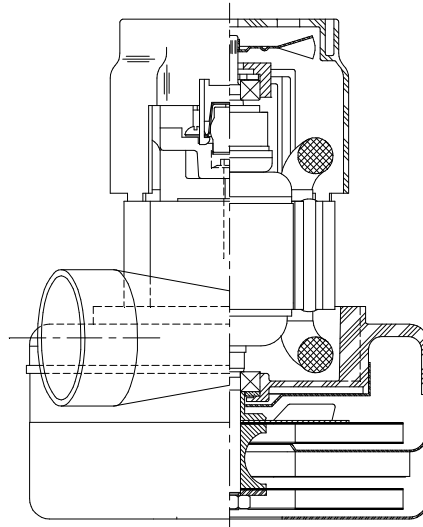

SPECIAL FEATURES

- Suitable for 120 volt AC operation 50/60 Hz
- UL recognized, category PRGY2 (E47185)
- CSA certified, class 1611 01 (LR31393)
- Provision for grounding
- Skeleton-frame design
- Non-loading fans
- The Lamb Electric vacuum motor line offers a wide range of performance levels to meet design needs

TYPICAL MOTOR PERFORMANCE.*

(At 120 volts, 60Hz, test data is corrected to standard conditions of 29.92 Hg, 68° F.)

ASTM DATA

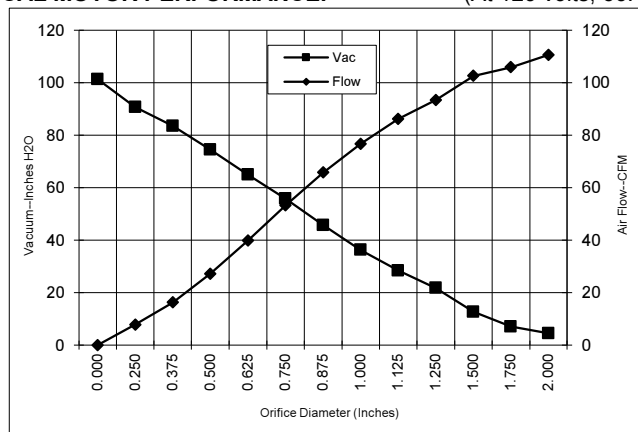

Orifice (Inches)	Amps	Watts (In)	RPM	Vac (In.H2O)	Flow (CFM)	Air Watts
2.000	12.6	1459	19840	4.5	110.6	58
1.750	12.6	1447	19830	7.1	105.9	88
1.500	12.5	1438	19840	12.7	102.6	153
1.250	12.3	1423	19930	21.8	93.4	239
1.125	12.2	1404	20090	28.4	86.2	287
1.000	11.8	1370	20340	36.3	76.7	327
0.875	11.4	1324	20770	45.7	65.8	353
0.750	10.9	1263	21320	55.8	53.3	349
0.625	10.2	1188	22110	65.0	39.8	304
0.500	9.3	1097	23070	74.5	27.2	238
0.375	8.4	997	24270	83.5	16.3	160
0.250	7.6	901	25270	90.7	7.8	83
0.000	7.0	833	26260	101.3	0.0	0

METRIC DATA

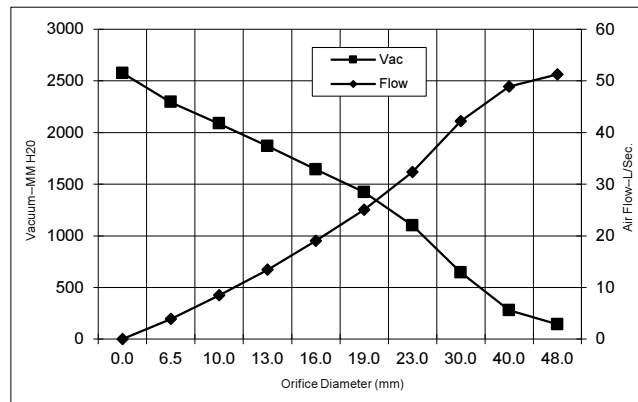

Orifice (mm)	Amps	Watts (In)	RPM	Vac (mm H2O)	Flow (L/Sec)	Air Watts
48.0	12.6	1454	19836	143	51.2	71
40.0	12.5	1441	19837	280	48.9	134
30.0	12.2	1413	20018	646	42.2	265
23.0	11.5	1336	20663	1101	32.3	347
19.0	10.9	1262	21336	1422	25.0	348
16.0	10.2	1191	22078	1642	19.0	306
13.0	9.4	1106	22974	1868	13.4	245
10.0	8.5	1012	24090	2087	8.5	172
6.5	7.6	906	25220	2295	3.9	87
0.0	7.0	833	26260	2573	0.0	0

Note: Metric performance data is calculated from the ASTM data above.

* Data represents performance of a typical motor sampled from a large production quantity. Individual motor data may vary due to normal manufacturing variations.

Test Specs:	120 volts	Minimum Sealed Vacuum: 90"	ORIFICE:	7/8"	Minimum Vacuum: 41"	Maximum Watts:	1540
--------------------	-----------	-----------------------------------	-----------------	------	----------------------------	-----------------------	------

DIMENSIONS

NOTES:

1. LEADS: 18GA STRANDED, LEADS CAN BE ANY COLOR EXCEPT GREEN OR GREEN WITH YELLOW STRIPE.
2. GROUNDING OR EARTHING PROVISIONS: USE HOLES AS INDICATED FOR GROUNDING OR EARTHING.
REFER TO APPROPRIATE LISTING OR REGULATORY AGENCY FOR PROPER METHOD OF GROUNDING OR EARTHING.
3. MOTOR IDENTIFICATION: MANUFACTURER'S NAME, MODEL NUMBER, VOLTAGE, FREQUENCY, INSPECTOR'S CODE, DATE OF MANUFACTURE, AGENCY RECOGNITION CODE, PLANT LOCATION CODE, PATENT INFORMATION "ONE OR MORE OF THE FOLLOWING U.S. PATENTS APPLY TO THIS MOTOR: 5482378; 5736805; 4669952; 4684835" AND COUNTRY OF ORIGIN.
4. ALLOW [0.0016 SQ M]/2.5 SQ IN. MIN. FOR COOLING AIR INTAKE.
5. COOLING AIR INTAKE MUST BE SEPARATED FROM COOLING AIR EXHAUST.
6. VACUUM EXHAUST MUST BE SEPARATED FROM COOLING EXHAUST.
7. MOUNTING MUST NOT RESTRICT THIS DIAMETER.

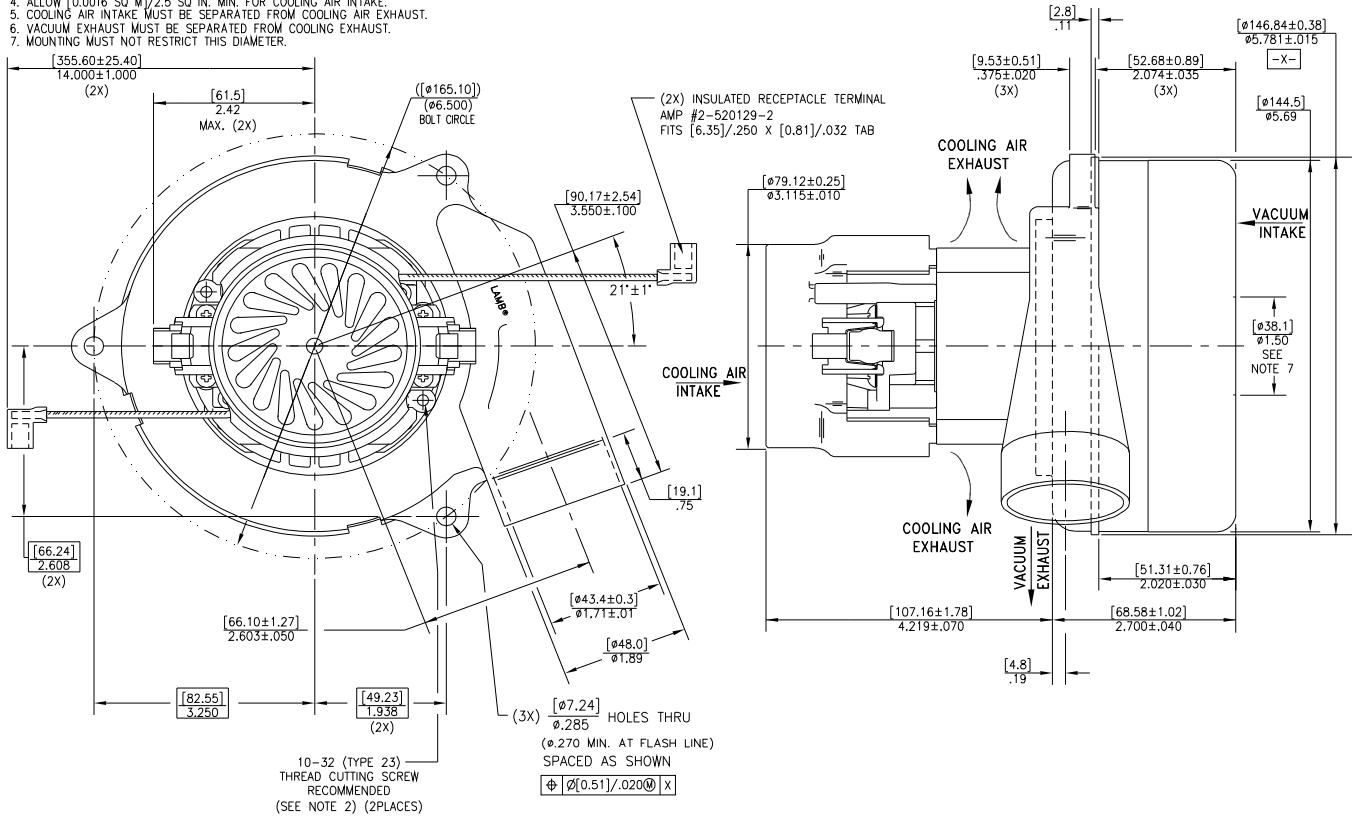

IMPORTANT NOTE: Pictorial and dimensional data are subject to change without notice. Contact factory for current revision levels.

WARNING - When using AMETEK Lamb Electric bypass motors in machines that come in contact with foam, liquid (including water), or other foreign substances, the machine must be designed and constructed to prevent those substances from reaching the fan system, motor housing, and electrical components. Lamb Electric vacuum motors other than hazardous duty models should not be applied in machines that come in contact with dry chemicals or other volatile materials. Failure to observe these precautions could cause flashing (depending on volatility) or electrical shock which could result in property damage and severe bodily injury, including death in extreme cases. All applications incorporating Lamb Electric motors should be submitted to appropriate organizations or agencies for testing specifically related to the safety of your equipment.

AMETEK Dynamic Fluid Solutions
www.ametekdfs.com