



DESCRIPTION

- Two stage
- 240 volts
- 5.7"/145 mm diameter
- Double ball bearings
- Single speed
- Tangential bypass discharge
- Thermoset fan end bracket
- Aluminum commutator bracket

DESIGN APPLICATION

- Equipment operating in environments requiring separation of working air from motor ventilating air
- Designed to handle clean, dry, filtered air only

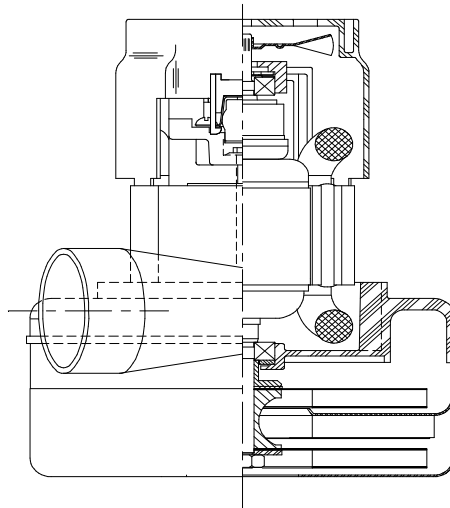

SPECIAL FEATURES

- Suitable for 240 volt AC operation, 50/60 Hz
- UL recognized, category PRGY2 (E47185)
- Provision for grounding
- Skeleton-frame design
- The Lamb Electric vacuum motor line offers a wide range of performance levels to meet design needs

TYPICAL MOTOR PERFORMANCE.*

(At 240 volts, 60Hz, test data is corrected to standard conditions of 29.92 Hg, 68° F.)

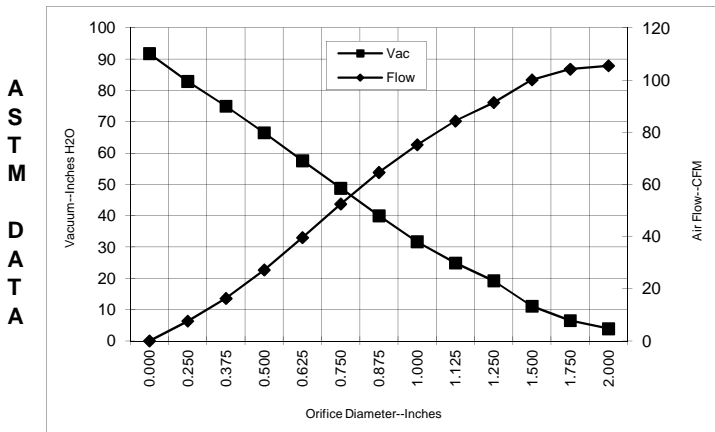

Orifice (Inches)	Amps	Watts (In)	RPM	Vac (In.H ₂ O)	Flow (CFM)	Air Watts
2.000	5.7	1288	18540	3.9	105.5	48
1.750	5.6	1287	18730	6.5	104.2	80
1.500	5.6	1282	18905	11.1	100.1	130
1.250	5.5	1268	19045	19.2	91.4	206
1.125	5.4	1248	19230	24.9	84.3	246
1.000	5.3	1210	19570	31.7	75.2	280
0.875	5.1	1169	19960	40.0	64.6	303
0.750	4.9	1112	20570	48.8	52.5	301
0.625	4.6	1047	21210	57.6	39.6	268
0.500	4.3	975	22250	66.5	27.2	212
0.375	3.9	897	23320	75.0	16.3	144
0.250	3.6	824	24450	82.9	7.6	74
0.000	3.3	761	25540	91.8	0.0	0

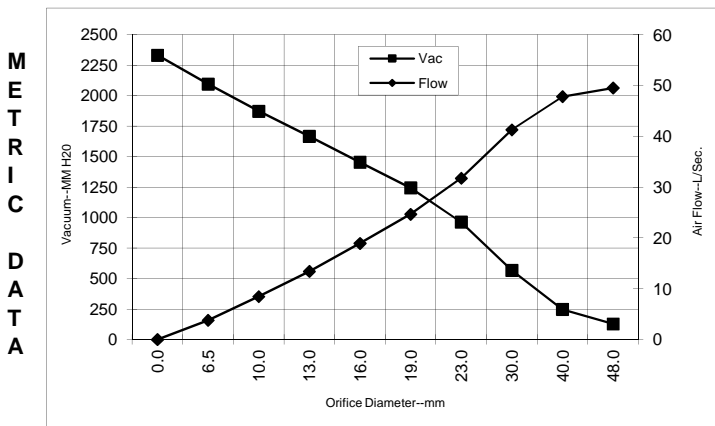

Orifice (mm)	Amps	Watts (In)	RPM	Vac (mm H ₂ O)	Flow (L/Sec)	Air Watts
48.0	5.7	1288	18624	128	49.5	62
40.0	5.6	1284	18853	247	47.8	115
30.0	5.4	1257	19147	567	41.3	228
23.0	5.2	1179	19863	963	31.7	297
19.0	4.9	1111	20583	1244	24.7	300
16.0	4.6	1050	21184	1454	18.9	269
13.0	4.3	982	22146	1666	13.4	218
S	4.0	909	23160	1873	8.5	154
6.5	3.6	828	24394	2096	3.8	78
0.0	3.3	761	25540	2332	0.0	0

Note: Metric performance data is calculated from the ASTM data above.

* Data represents performance of a typical motor sampled from a large production quantity. Individual motor data may vary due to normal manufacturing variations.

Test Specs:	240 volts	Minimum Sealed Vacuum:	88.0"	ORIFICE:	13mm	Minimum Vacuum:	65.0"	Maximum Watts:	1150
--------------------	-----------	-------------------------------	-------	-----------------	------	------------------------	-------	-----------------------	------

DIMENSIONS

NOTES:

1. LEADS: 18GA STRANDED, LEADS CAN BE ANY COLOR EXCEPT GREEN OR GREEN WITH YELLOW STRIPE.
2. GROUNDING OR EARTHING PROVISIONS: USE HOLES AS INDICATED FOR GROUNDING OR EARTHING. REFER TO APPROPRIATE LISTING OR REGULATORY AGENCY FOR PROPER METHOD OF GROUNDING OR EARTHING.

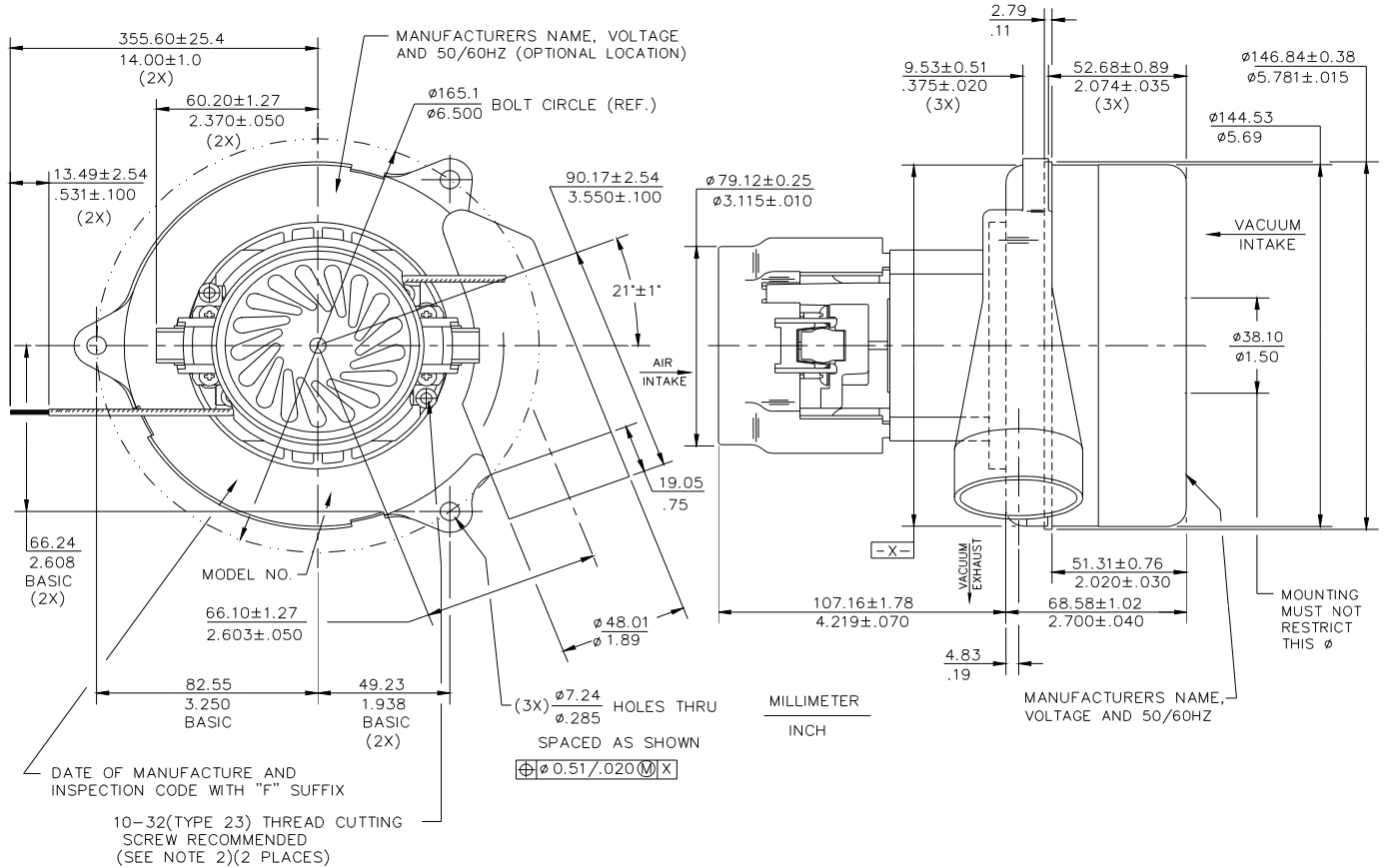

IMPORTANT NOTE: Pictorial and dimensional data are subject to change without notice. Contact factory for current revision levels.

WARNING - When using AMETEK Lamb Electric bypass motors in machines that come in contact with foam, liquid (including water), or other foreign substances, the machine must be designed and constructed to prevent those substances from reaching the fan system, motor housing, and electrical components. Lamb Electric vacuum motors other than hazardous duty models should not be applied in machines that come in contact with dry chemicals or other volatile materials. Failure to observe these precautions could cause flashing (depending on volatility) or electrical shock which could result in property damage and severe bodily injury, including death in extreme cases. All applications incorporating Lamb Electric motors should be submitted to appropriate organizations or agencies for testing specifically related to the safety of your equipment.

AMETEK/Floorcare & Specialty Motors
www.ameteksm.com