



**AMETEK**

**LAMB ELECTRIC**

**Product Bulletin**

**Model: 116565-00  
116565-13\***

**DESCRIPTION**

- Three stage
- 120 volts
- 5.7"/145 mm diameter
- Double ball bearings
- Single speed
- Tangential bypass discharge
- Thermoset fan end bracket
- Aluminum commutator bracket

**DESIGN APPLICATION**

- Equipment operating in environments requiring separation of working air from motor ventilating air
- Designed to handle clean, dry, filtered air only

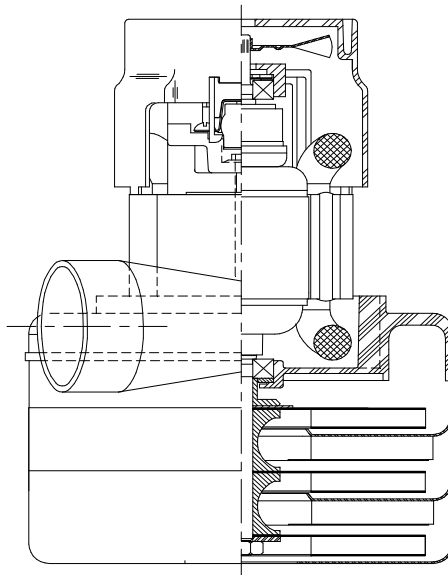

**SPECIAL FEATURES**

- Suitable for 120 volt AC operation, 50/60 Hz
- UL recognized, category PRGY2 (E47185)
- CSA certified, class 1611 01 (LR31393)
- Provision for grounding
- Skeleton-frame design
- The Lamb Electric vacuum motor line offers a wide range of performance levels to meet design needs.

**\*Model 116565-13 features patented air seal bearing construction, U.S. Patent #4,088,424 and epoxy painted fan case**

**TYPICAL MOTOR PERFORMANCE.\***

(At 120 volts, 60Hz, test data is corrected to standard conditions of 29.92 Hg, 68° F.)

**ASTM DATA**

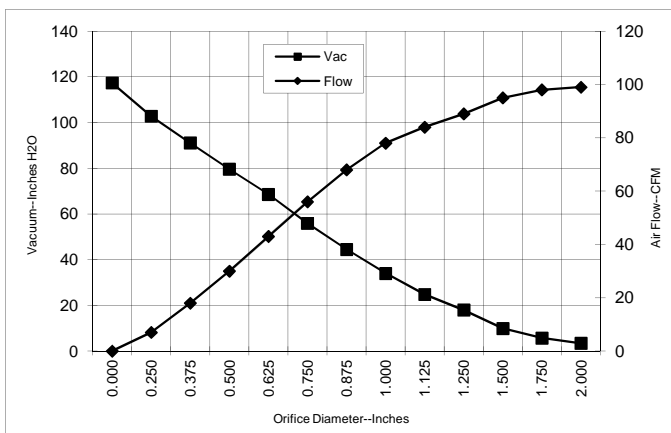

Orifice (Inches)	Amps	Watts (In)	RPM	Vac (In.H2O)	Flow (CFM)	Air Watts
2.000	10.4	1227	17500	3.4	99.0	39
1.750	10.5	1233	17500	5.7	98.0	65
1.500	10.6	1240	17500	9.9	95.0	110
1.250	10.6	1246	17400	18.0	89.0	187
1.125	10.6	1252	17300	24.8	84.0	244
1.000	10.7	1258	17300	34.0	78.0	310
0.875	10.6	1250	17400	44.5	68.0	356
0.750	10.3	1212	17700	55.9	56.0	368
0.625	9.7	1147	18300	68.6	43.0	347
0.500	9.1	1071	19200	79.6	30.0	278
0.375	8.4	988	20300	91.1	18.0	191
0.250	7.4	886	21400	102.8	7.0	102
0.000	6.7	796	22200	117.4	0.0	0

**METRIC DATA**

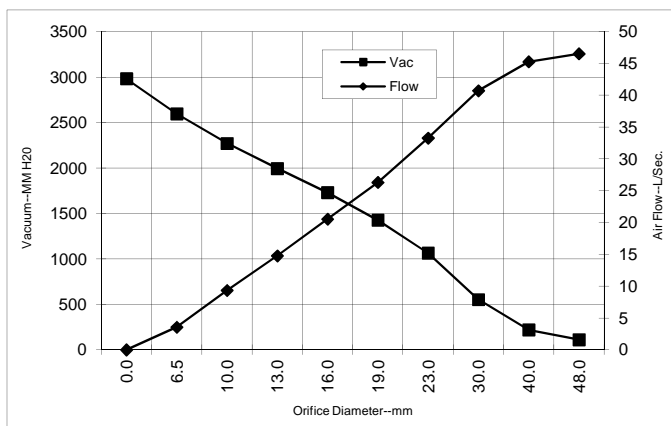

Orifice (mm)	Amps	Watts (In)	RPM	Vac (mm H2O)	Flow (L/Sec)	Air Watts
48.0	10.4	1230	17500	112	46.5	50
40.0	10.6	1238	17500	219	45.3	97
30.0	10.6	1249	17345	552	40.7	218
23.0	10.6	1252	17375	1064	33.3	345
19.0	10.3	1211	17712	1426	26.3	368
16.0	9.7	1150	18276	1730	20.5	348
13.0	9.2	1079	19110	1994	14.8	285
10.0	8.5	1000	20135	2270	9.3	204
6.5	7.5	891	21345	2596	3.6	106
0.0	6.7	796	22200	2982	0.0	0

Note: Metric performance data is calculated from the ASTM data above.

\* Data represents performance of a typical motor sampled from a large production quantity. Individual motor data may vary due+A43 to normal manufacturing variati

<b>Test Specs:</b>	120 volts	<b>Minimum Sealed Vacuum:</b> 112"	<b>ORIFICE:</b>	7/8 "	<b>Minimum Vacuum:</b> 40"	<b>Maximum Watts:</b>	1425
--------------------	-----------	------------------------------------	-----------------	-------	----------------------------	-----------------------	------

**DIMENSIONS**

NOTES:

1. LEADS: 18 GA. STRANDED, LEADS CAN BE ANY COLOR EXCEPT GREEN OR GREEN WITH YELLOW STRIPE.
2. GROUNDING OR EARTHING PROVISIONS: USE HOLES AS INDICATED FOR GROUNDING OR EARTHING. REFER TO APPROPRIATE LISTING OR REGULATORY AGENCY FOR PROPER METHOD OF GROUNDING OR EARTHING.

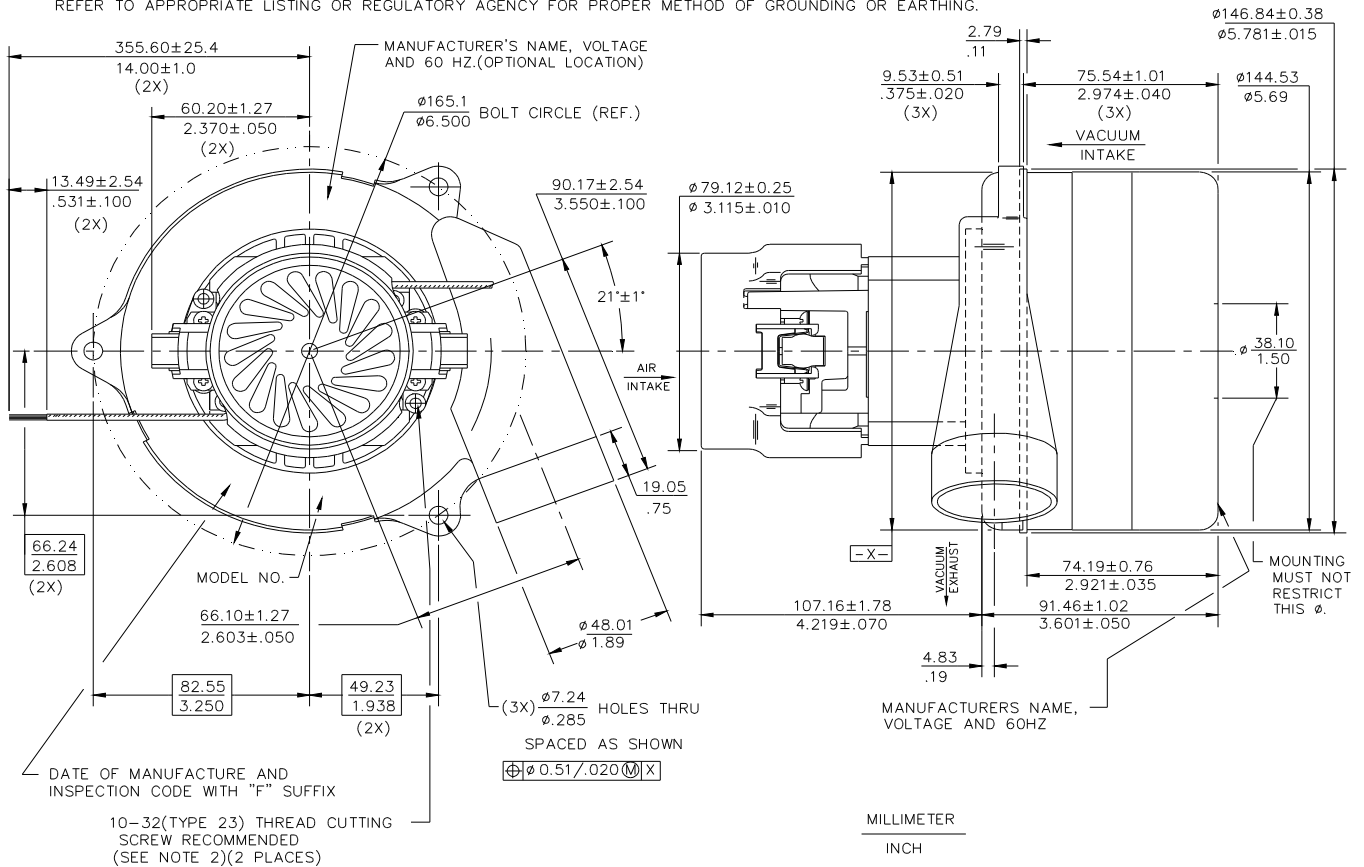

**IMPORTANT NOTE:** Pictorial and dimensional data are subject to change without notice. Contact factory for current revision levels.

**WARNING** - When using AMETEK Lamb Electric bypass motors in machines that come in contact with foam, liquid (including water), or other foreign substances, the machine must be designed and constructed to prevent those substances from reaching the fan system, motor housing, and electrical components. Lamb Electric vacuum motors other than hazardous duty models should not be applied in machines that come in contact with dry chemicals or other volatile materials. Failure to observe these precautions could cause flashing (depending on volatility) or electrical shock which could result in property damage and severe bodily injury, including death in extreme cases. All applications incorporating Lamb Electric motors should be submitted to appropriate organizations or agencies for testing specifically related to the safety of your equipment.

**AMETEK/Floorcare & Specialty Motors**  
[www.ametekfsm.com](http://www.ametekfsm.com)