

Dual-Purpose Hand Truck

- Dual-function hand truck converts to platform position for oversize loads.
- 40"H hand truck.
- 37"L platform bed.
- Welded, 1" structural pipe frame with 1/8" walls.
- Large, 7" x 14" nose plate.
- Up to 600 lbs. capacity in platform mode.
- Color: 4008 Model is Red, 4010 Models are Silver.

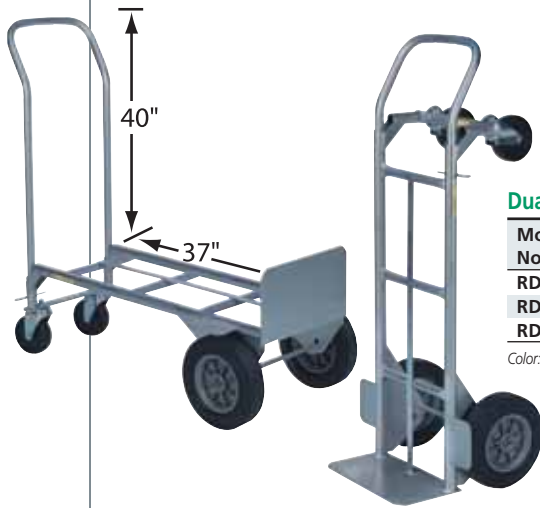

Dual-Purpose Hand Truck

Model No.	Wheel Type	Wheel/Caster Size	Overall Height Inches	Overall Height mm	Overall Width Inches	Overall Width mm	Ship Wt.
RDT4008SP	Semi-Pneumatic	8"/3" (203/76)	46	1168	19 ⁹ / ₈	498	46 lbs.
RDT4010FP	Full Pneumatic	10"/5" (254/127)	46	1168	22	559	50 lbs.
RDT4010SP	Semi-Pneumatic	10"/5" (254/127)	46	1168	20	508	50 lbs.

Color: 4008 Model is Red, 4010 Models are Silver.

Pail Truck



- Multi-purpose hand truck for carting 5-gallon pails.
- Cross straps with supporting arms hold pails in place while in transit.
- Welded, 1" structural pipe frame with 1/8" walls.
- Up to 300 lbs. capacity.
- RPT40 holds 4 pails, RPT50 holds 5 pails.

Pail Truck

Model No.	Wheel Type	Wheel Size Inches	Wheel Size mm	Overall Height Inches	Overall Height mm	Overall Width Inches	Overall Width mm	Ship Wt.
RPT4010SP	Semi-Pneumatic	10	254	55	1397	18	457	46 lbs.
RPT5010SP	Semi-Pneumatic	10	254	67 ¹ / ₂	1715	18	457	50 lbs.